



Bag gripper

Handling system for bags

THE KNOW-HOW FACTORY

BAG GRIPPER

SYSTEM SOLUTIONS

HANDLING SYSTEM FOR BAGS

The Zimmer Group bag gripper is a one-of-a-kind end-of-arm system for handling bags filled with a wide variety of products. These include flour, fruit, vegetables, grain, fertilizer, chemicals, cement or numerous other products. At the same time, the materials of the bags to be handled also vary, including paper, plastic, jute and (woven) fabric.

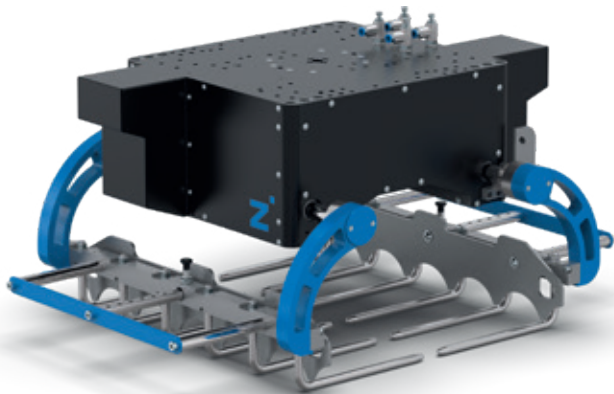

Bag gripper
Order no. BAG137256

PRODUCT ADVANTAGES

- ▶ Rigid, durable and fast bag gripper for end-of-line pick and place or palletizing solution
- ▶ Modular gripper which handles a variety of bags and materials
- ▶ Easily adaptable, ready-to-install accessories provide efficiency and increased productivity
- ▶ Lightweight and ready-to-mount solutions can help get projects done faster
- ▶ Proven industry-standard solution ensures longevity, uptime and easy maintenance



IP54



Pneumatic



External gripping



Synchronized gripper jaws



Gripping force safety device for pressure maintenance

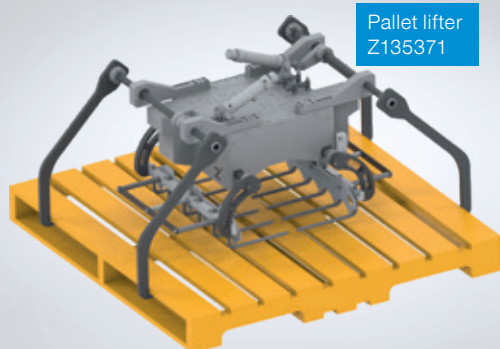

Pallet lifter
Z135371

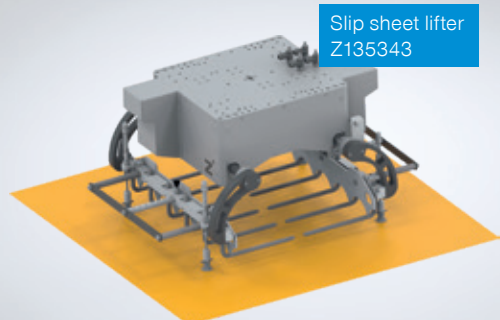

Slip sheet lifter
Z135343

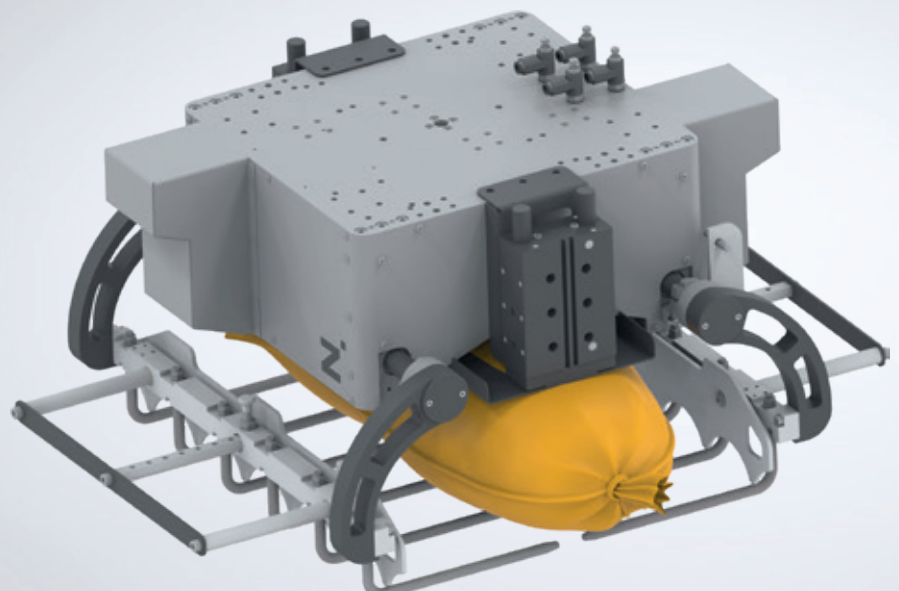

Top pressure unit/hold-down device
Z135374 and Z137857

FUNCTIONS AND DETAILS

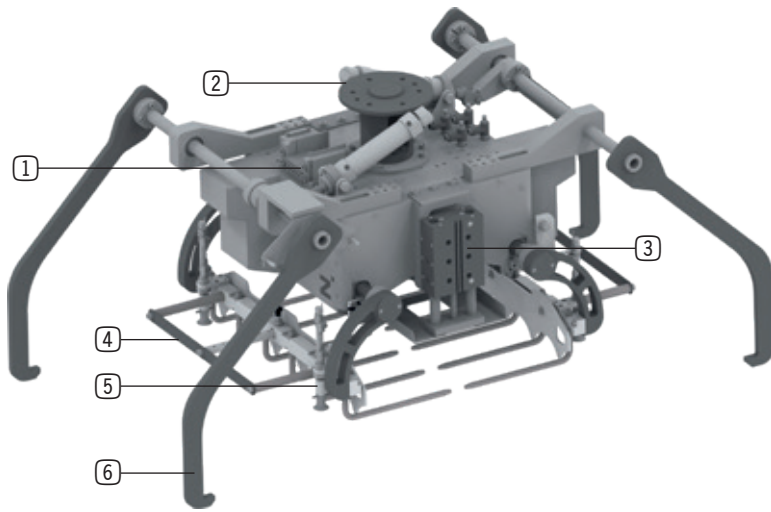

- ① Accessories: Valve terminal
- ② Accessories: Robot connecting flange
- ③ Accessories: Pressure unit (height 75-150 mm)
- ④ Adjustable jaw (width 170-430 mm)
- ⑤ Accessories: Intermediate layer gripper
- ⑥ Accessories: Pallet gripper

TECHNICAL DATA – STANDARD

	Unit	Workpiece weight	Dimension max. (lxbxh)	Dimension min. (lxbxh)	System weight	Closing time/Opening time
Order no.		[kg]	[mm]	[mm]	[kg]	[sec]
BAG137256	Bag gripper	25	600 x 430 x 150	600 x 170 x 75	45	0.6
BAG137855	Bag gripper	50	700 x 500 x 175	700 x 300 x 100	55	0.6
BAG165171	Double bag gripper	25+25	600 x 430 x 150 + 600 x 430 x 150	600 x 170 x 75 + 600 x 170 x 75	115	0.6

TECHNICAL DATA – OPTIONS

	Unit	Workpiece weight	Dimension max. (lxbxh)	Dimension min. (lxbxh)	System weight	Closing time/Opening time
Order no.		[kg]	[mm]	[mm]	[kg]	[sec]
Z135374	Top press unit [Accessory]	25	600 x 430 x 150	600 x 170 x 75	15	0.5
Z137857	Hold-down device [Accessory]	50	700 x 500 x 175	700 x 300 x 100	15	0.5
Z135343	Intermediate layer gripper [Accessory]	-	1200 x 1200	1000 x 1000	5	0.5
Z135371	Pallet lifter [Accessory]	-	1200 x 1200	1000 x 1000	30	2
Z165169* (on request)	Robot adapter Plate type	-	-	-	3	NA
Z165170* (on request)	Robot adapter Structure type	-	-	-	5.5	NA
Z165147** (on request)	Pneumatic arrangements (valve, banks, etc.)	-	-	-	-	-

* Z165169 and Z165170 as reference numbers. Specific numbers for respective robot on request.

** Z165147 as reference number. Specific numbers for different combinations on request.

ZIMMER GROUP – THE KNOW-HOW FACTORY

OUR KNOW-HOW FACTORY WORKS WITH ALL INDUSTRIES AND DELIVERS EVERYTHING FROM A SINGLE SOURCE. OUR PRODUCT RANGE IS FAR REACHING, BOTH IN ITS DEPTH AND ITS BREADTH.

DO YOU HAVE A DEVELOPMENT PROBLEM? WE'LL SOLVE IT! SET US A CHALLENGE IN RESEARCH AND DEVELOPMENT. COUNTLESS INNOVATIONS ORIGINATE FROM OUR COMPANY. WE ARE ENTHUSIASTIC ABOUT NEW PRODUCTS AND PRIDE OURSELVES ON OUR CORPORATE PIONEERING SPIRIT.

CONTACT – WORLDWIDE

With our current 17 global subsidiaries and partners in over 125 countries, we offer the excellent service of a technology leader. We look forward to hearing from you!

www.zimmer-group.com/en-us/contact



ZIMMER GROUP SYSTEM TECHNOLOGY – THE SPECIALISTS FOR CUSTOM SOLUTIONS

With over 30 years of development experience, the system technology develops special solutions for handling and automation.

www.zimmer-group.com/en-us/system-technology



HERE FOR YOU 24/7/365 – OUR VIRTUAL TRADE SHOW BOOTH

With impressive features such as an animated camera flight, clickable information hotspots and 3D models that can be rotated, we guarantee that you will be thrilled—virtually.

www.zimmer-group.com/en-us/expo



OUR NEW PRODUCTS

Zimmer Group is renowned as an innovator and for its pioneering spirit. Accordingly, each year we can offer new innovative and individual solutions. For current product highlights, refer to:

www.zimmer-group.com/en-us/innovations



HEADQUARTERS:

ZIMMER GROUP

Am Glockenloch 2
DE 77866 Rheinau
T +49 7844 9139-0
F +49 7844 9139-1199
info.de@zimmer-group.com
www.zimmer-group.com