



INSTALLATION AND OPERATING INSTRUCTIONS

Long-stroke axis with spindle
drive

AMS

DDOC01821

THE KNOW-HOW FACTORY

Content

- 1 Supporting documents 4
 - 1.1 Notices and graphics in the installation and operating instructions4
- 2 Safety notices 5
- 3 Proper use 6
- 4 Personnel qualification 6
 - 4.1 Electricians6
 - 4.2 Specialists6
 - 4.3 Instructed personnel.....6
 - 4.4 Service personnel.....6
 - 4.5 Additional qualifications6
- 5 Product description 7
 - 5.1 Type plate8
 - 5.2 Product variants8
 - 5.2.1 Clamping element8
 - 5.2.2 Slides9
 - 5.2.3 Cover strip9
- 6 Functional description 10
 - 6.1 Position measuring system10
- 7 Technical data 10
- 8 Accessories/scope of delivery 10
- 9 Transportation/storage/preservation 11
 - 9.1 Transporting the product11
- 10 Installation 12
- 11 Installing the product 13
 - 11.1.1 Installing the product with T-slot nuts14
 - 11.1.2 Installing the product with clamping claws14
 - 11.1 Installing the sensors.....15
 - 11.2 Installing the drive16
 - 11.2.1 Installing the motor16
 - 11.3 Installing the customer-specific application18
 - 11.3.1 Installing the pneumatic system18
 - 11.3.2 Installing the electronics19
- 12 Commissioning 21
 - 12.1 Checking operational readiness21
 - 12.2 Preparing for commissioning22
 - 12.2.1 Device configuration23
 - 12.2.2 Configuring the drive control unit24
 - 12.3 Making settings in the project25
 - 12.4 Adding technology objects26
 - 12.5 Referencing by Homing30
 - 12.6 Using the function block31
 - 12.7 Function in the function block31
 - 12.7.1 Monitoring and switching on31
 - 12.7.2 References33
 - 12.7.3 Manual control33
 - 12.7.4 Easy Move motion33
 - 12.7.5 Absolute movement34
 - 12.7.6 Setting and monitoring34

13 Error diagnosis 35

14 Maintenance 37

 14.1 Relubricating the product 38

 14.2 Replacing the cover strip 39

15 Decommissioning/disposal 40

16 RoHS declaration 41

17 REACH declaration 41

18 Declaration of Incorporation 42

1 Supporting documents

NOTICE



Read through the installation and operating instructions before installing or working with the product.

The installation and operating instructions contain important notes for your personal safety. They must be read and understood by all persons who work with or handle the product during any phase of the product lifetime.



The documents listed below are available for download on our website www.zimmer-group.com.

- Installation and operating instructions
 - Catalogs, drawings, CAD data, performance data
 - Information on accessories
 - Technical data sheets
 - General Terms and Conditions, including warranty information.
- ⇒ Only those documents currently available on the website are valid.

In these installation and operating instructions, "product" refers to the product designation on the title page!

1.1 Notices and graphics in the installation and operating instructions

DANGER



This notice warns of an imminent danger to the life and health of people. Ignoring these notices can lead to serious injury or even death.

- ▶ You absolutely must comply with the described measures for avoiding these dangers!
- ⇒ The warning symbols are assigned according to the type of danger.

WARNING



This notice warns of a situation that is potentially hazardous to personal health. Ignoring these notices can cause serious injury or damage to health.

- ▶ You absolutely must comply with the described measures for avoiding these dangers!
- ⇒ The warning symbols are assigned according to the type of danger.

CAUTION



This notice warns of a situation that is potentially hazardous to persons. Ignoring these notices can cause minor, reversible injuries.

- ▶ You absolutely must comply with the described measures for avoiding these dangers!
- ⇒ The warning symbols are assigned according to the type of danger.

NOTICE



This notice warns of possible material and environmental damage. Ignoring these notices can result in damage to the product or the environment.

- ▶ You absolutely must comply with the described measures for avoiding these dangers!
- ⇒ The warning symbols are assigned according to the type of danger.

INFORMATION



This category contains useful tips for handling the product efficiently. Failure to observe these tips will not result in damage to the product. This information does not include any information relevant to health or workplace safety.

2 Safety notices

WARNING



Risk of injury from crushing

There is a risk of crushing injuries between the carriage and the end block.

- ▶ Make sure that there are no parts of the body in the range of movement of the product!

CAUTION



Risk of injury and material damage in case of non-compliance

The product is state-of-the-art.

The following are examples of situations in which the product may cause a hazard:

- The product is not properly installed, used or maintained.
- The product is not used for its designated purpose.
- The locally applicable regulations, laws, directives or guidelines are not observed.
- ▶ The product may only be used in accordance with these installation and operating instructions and the product's technical data. Any changes or additions to the intended use of the product, as well as modifications to the product, such as those in the following examples, require the written permission of the manufacturer:
 - Use of the product under extreme conditions, such as aggressive fluids or abrasive dusts
 - Additional drilled holes or threads
- ⇒ Zimmer GmbH shall accept no liability for any damage caused by improper use. The operator bears sole responsibility.
- ▶ Make sure that the power supply is disconnected before you mount, adjust, modify, maintain or repair the product.
- ▶ Whenever work is carried out on the product, make sure that the product cannot be actuated by mistake.
- ▶ Perform maintenance tasks, renovation work or attachment work outside of the machine's danger zone when possible.
- ▶ Do not reach into the operational range of the product.
- ▶ Never stand within the operational range of the product.
- ▶ Observe the specified maintenance intervals and specifications regarding the quality of the operating material.
- ▶ When using the product under extreme conditions, adjust the maintenance interval according to the degree of contamination.
- ▶ Check the completeness and tightening torques of all mounting screws.

3 Proper use

NOTICE



Material damage and malfunction in case of non-compliance

The product is only to be used in its original state with its original accessories, with no unauthorized changes and within the stipulated parameter limits and operating conditions.

Any other or secondary use is deemed improper.

- ▶ Operate the product only in compliance with the associated installation and operating instructions.
 - ▶ Operate the product only when it is in a technical condition that corresponds to the guaranteed parameters and operating conditions.
- ⇒ Zimmer GmbH shall accept no liability for any damage caused by improper use. The operator bears sole responsibility.

- The product is designed for moving and positioning loads within automated systems.
- The product is intended for industrial use.
- The product is designated for use in closed facilities.
- The product is not suited for use in a potentially explosive atmosphere.
- Direct contact with perishable goods/food is not permitted.

4 Personnel qualification

WARNING



Inadequate qualification can cause injury and material damage

If inadequately qualified personnel perform work on the product, this can cause serious injuries and significant material damage.

- ▶ All work on the product must be performed by qualified personnel.
- ▶ Before working with the product, read the document in its entirety and make sure that you have understood everything.
- ▶ Observe country-specific accident prevention regulations and the general safety notices.

The following qualifications are a prerequisite for performing various work on the product.

4.1 Electricians

Electricians are able to perform work on electrical systems, can recognize and avoid possible dangers and know the relevant standards and provisions due to their technical training, knowledge and experience.

4.2 Specialists

Specialists are able to perform the assigned work, can recognize and avoid possible dangers and know the relevant standards and provisions due to their technical training, knowledge and experience.

4.3 Instructed personnel

Instructed personnel have been trained by the operating company on the tasks and possible dangers of improper behavior.

4.4 Service personnel

Service personnel are able to perform the assigned work and can recognize and avoid possible dangers due to their technical training, knowledge and experience.

4.5 Additional qualifications

Persons who work with the product must be familiar with the valid safety regulations and laws as well as the standards, guidelines and laws listed in this document.

Personnel who work with the product must have facility-issued authorization to commission, program, configure, operate, maintain and also decommission this product.

5 Product description

The product is a long-stroke axis with spindle drive.

The optional drive consists of a clutch, adapter plates and motor.

The following illustrations depict example product variants.

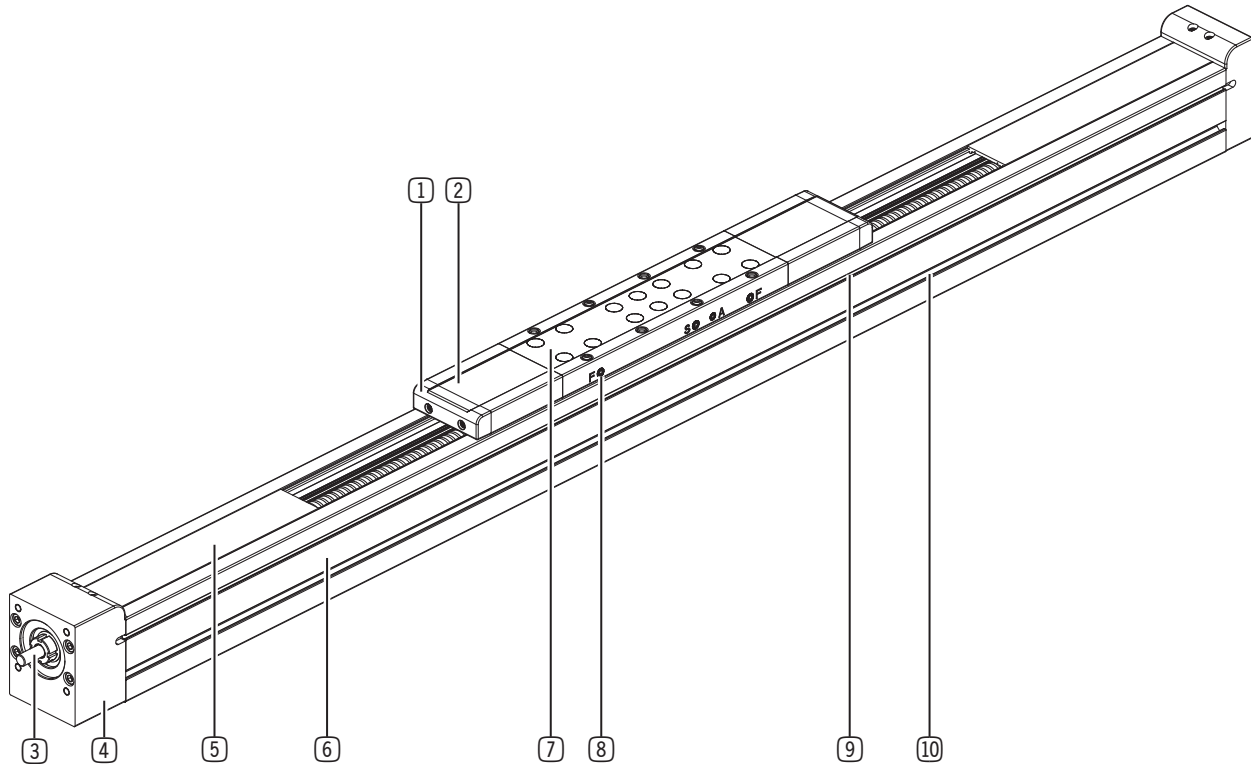

- ① Carriage end piece
- ② Cover strip guide
- ③ Spindle
- ④ End block
- ⑤ Cover strip

- ⑥ Axis profile
- ⑦ Slides
- ⑧ Lubrication points
- ⑨ Sensor slot
- ⑩ Assembly slot

5.1 Type plate

A type plate is attached to the product.
The type plate shows the part number and serial number.

- ① Article number
- ② Type key
- ③ Confirmation number

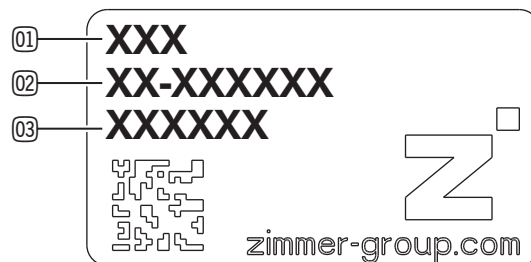

5.2 Product variants

Order number	Meaning	Variant		
AM	Axis type	-		
S	Drive type	S: Spindle drive		
060	Installation size [mm]	040: 40 060: 60 080: 80 120: 120		
5999	Stroke	Configurable stroke length [mm]		
C	Clamping element	C: with clamping element D: without clamping element		
M	Carriage size and quantity	Carriage size:	Carriage quantity:	Carriage combinations: SL: 1xS, 1xL
		S1: 1x S L1: 1x L	S2: 2x S L2: 2x L	
C	Cover strip	C: with cover strip D: without cover strip		

5.2.1 Clamping element

During configuration, a clamping element can be selected starting from installation size 60.
The clamping element has a spring energy accumulator that maintains the clamping process even in the depressurized state. When the clamping element is pressurized, the clamping process is interrupted and the guide rail is released.

5.2.2 Slides

A variety of carriage variants are available for this product.

INFORMATION



The carriage sizes depend on the axis profile. As a result, the slides have different dimensions depending on the installation size selected.

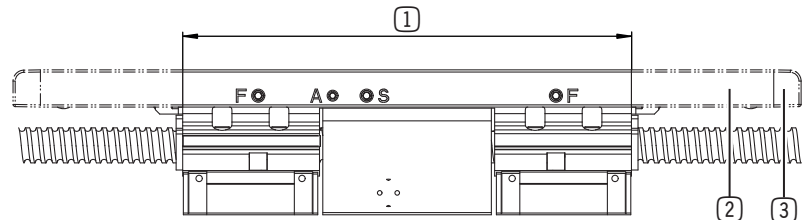

- ① Carriage length
- ② Cover strip guide
- ③ Carriage end piece

Installation size [mm]	Carriage length S [mm]	Carriage length L [mm]
40	160	200
60	205	300
80	254	380
120	400	600

5.2.3 Cover strip

During configuration, a cover strip can be selected that protects the product from the ingress of dust and dirt.

INFORMATION



- The entire length of the carriage structure consists of the carriage length as well as the required cover strip guide for the product variants with a cover strip.
- The optional cover strip cannot be retrofitted.

6 Functional description

The product has a ball screw that is driven by an electric motor. The carriage is attached to the nut that moves along the spindle and performs a linear movement as a result. The desired stroke can be selected in millimeter increments during configuration. The servo drive regulates the position and speed so that each position can be adjusted safely and precisely.

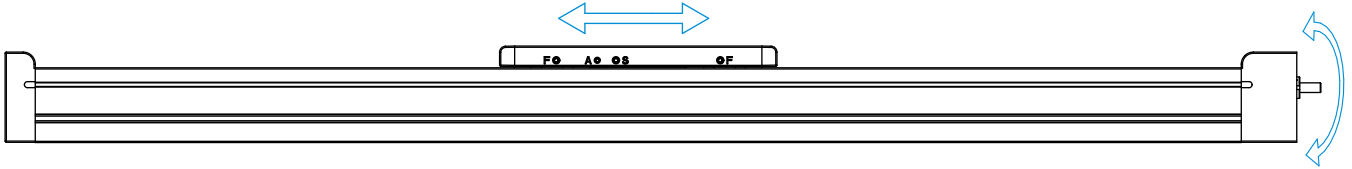

6.1 Position measuring system

The drive of the product has a motor with a multiturn absolute encoder.

- Encoder AM22DQC: Absolute encoder 22 bit + 12 bit multiturn

The multiturn absolute encoder is suitable for safety functions.

A zero point must be specified during commissioning because the position of the motor shaft is not defined during installation.

7 Technical data

INFORMATION



▶ You can find the information in the technical data sheet or Configurator on our website.

This data varies within the series, depending on the specific design.

▶ Please contact Customer Service if you have any questions.

8 Accessories/scope of delivery

INFORMATION



If any accessories not sold or authorized by Zimmer GmbH are used, the function of the product cannot be guaranteed. Zimmer GmbH accessories are specifically tailored to the individual products.

▶ For optional accessories and those included in the scope of delivery, refer to our website.

Manufacturer	Component	Website
Siemens	Motor	www.siemens.com
Siemens	Drive control unit	www.siemens.com

9 Transportation/storage/preservation

CAUTION



Risk of injury when transporting heavy loads

Minor to severe injury may occur when transporting by hand.

- ▶ Wear suitable protective equipment.
- ▶ Secure the product from falling, dropping or slipping during transport.

- ▶ Transport and storage of the product must be done only with the original packaging.
- ▶ If the product has already been installed on the superordinate machine unit, care must be taken during transport to ensure that no unexpected movements can occur.
 - ▶ Before commissioning the product and after transport, check all power and communication connections as well as all mechanical connections.
- ▶ If the product is stored for an extended period, the following points are to be observed:
 - ▶ Keep the storage location as dust-free and dry as possible.
 - ▶ Avoid temperature fluctuations.
 - ▶ Avoid wind/drafts/water condensation formation.
 - ▶ Pack the product and do not expose it to direct sunlight during storage.
- ▶ Clean all components. There must be no soiling left on the components.
- ▶ Visually inspect all components.
- ▶ Remove all foreign substances.

9.1 Transporting the product

NOTICE



Risk of material damage when transporting without proper support

Long axis profiles can sag when transported improperly.

- ▶ Lift the product at the supporting points according to the figure.
- ▶ Use suitable lifting gear and attachment equipment with sufficient load capacity.
- ▶ When lifting the product, it must be secured, e.g. using belts, at suitable intervals.
- ▶ Do not subject the product to additional loads during transport.
- ▶ Do not lift the product at the attachment parts.
- ▶ Add additional support to heavy attachment parts.

- ▶ Position the belt from the outside to the inside at one quarter intervals of the entire length.

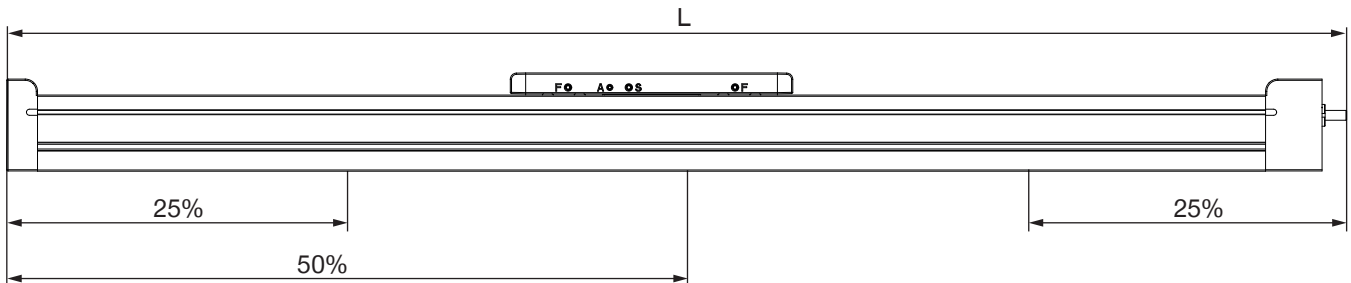

10 Installation

WARNING



Risk of injury due to uncontrolled movements

Risk of injury in case of unexpected movement of the machine or system into which the product is to be installed.

- ▶ Switch off the energy supply of the machine before any work.
- ▶ Secure the power supply against being switched on unintentionally.
- ▶ Check the machine for any residual energy that may be present.

WARNING



Suspended loads can cause injury

Falling loads can cause severe injuries.

- ▶ Always keep an adequate safety distance from suspended loads.
- ▶ Do not stand or walk underneath suspended loads.

CAUTION



Risk of injury due to uncontrolled movements

Risk of injury in the event of uncontrolled movement of the product when the power supply is connected.

- ▶ Switch off the power supply to the machine before carrying out any work.
- ▶ Secure the power supply against being switched on unintentionally.
- ▶ Check the machine for any residual energy that may be present.

CAUTION



Risk of injury due to uncontrolled movements

The carriage can sag and cause crushing if not used horizontally or if product variants are used that do not have a clamping element.

- ▶ Secure the carriage against unintentional movements.

CAUTION



Risk of injury due to uncontrolled movements

Improper handling can cause the product to fall and cause crushing.

- ▶ Secure the product from falling, dropping or slipping during transport.
- ▶ Wear suitable protective equipment.

Assembly requirements

Permissible flatness tolerance [mm/m]	0.2
Strength class of the mounting screws	8.8

INFORMATION



Further installation information:

- The mounting screws are not included in the scope of delivery.

- ▶ Install the product on an appropriate mounting surface in accordance with the flatness specifications.
- ▶ Make sure that the mounting piece is sufficiently rigid.
- ▶ Ensure the cleanliness of the connection surfaces.
- ▶ Please note the permitted tightening torques of the mounting screws at www.zimmer-group.com/en/td.

11 Installing the product

WARNING



Risk of injury and material damage in case of non-compliance

If unsuitable mounting elements are used or if the number of mounting elements is insufficient, the product may tear off as a result of the load.

- ▶ Use suitable mounting screws.
- ▶ Maintain the required minimum number of mounting elements depending on the load.
- ▶ Comply with the permitted tightening torques of the mounting screws.
- ▶ Use threadlocker.

CAUTION



Material damage in case of installation without suitable support

Long profiles can sag in case of improper installation.

- ▶ Install the product with supports at multiple points depending on the length or on a continuous, even mounting surface.

NOTICE



Non-compliance may result in material damage.

The product can be installed in any position.

The installation is performed via the axis profile using mounting elements.

- ▶ Please note that the orientation selected in the Configurator must correspond to the installation.

11.1.1 Installing the product with T-slot nuts

- ▶ Calculate the required number of mounting elements.
- ▶ Drill appropriately sized holes in the mounting piece.
- ▶ Clean the mounting surfaces.
- ▶ Swivel the mounting elements into the groove on the axis profile.
- ▶ Position the product on the mounting piece.
- ▶ Install the product to the mounting piece by screwing the mounting screws into the T-slot nuts.
- ▶ Comply with the permitted tightening torques of the mounting screws.

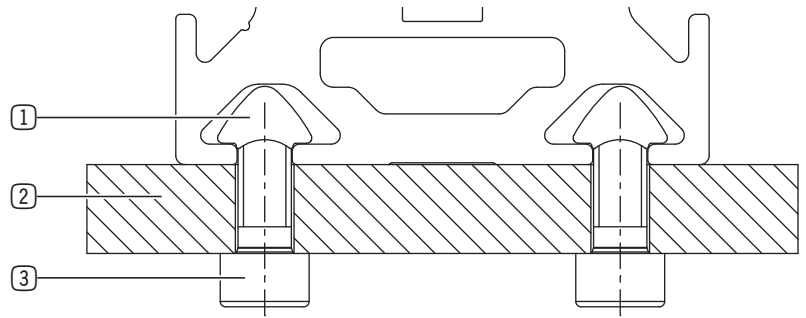

- ① T-slot nut
- ② Mounting piece
- ③ Mounting screw

11.1.2 Installing the product with clamping claws

- ▶ Calculate the required number of mounting elements.
- ▶ Drill appropriately sized holes in the mounting piece.
- ▶ Clean the mounting surfaces.
- ▶ Position the product on the mounting piece.
- ▶ Swivel the mounting elements into the groove on the axis profile.
- ▶ Mount the product by screwing the mounting screws into the mounting piece.
- ▶ Comply with the permitted tightening torques of the mounting screws.

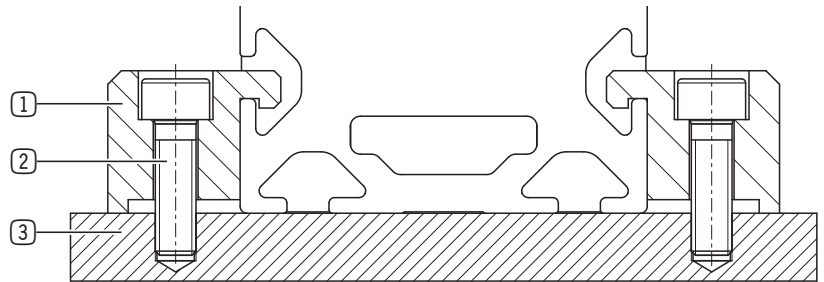

- ① Clamping claws
- ② Mounting screw
- ③ Mounting piece

11.1 Installing the sensors

The sensors define the end positions of the carriage. They act as a safety component by limiting the travel path before there is a collision between the carriage and the end position.

- ▶ Slide the sensor bracket into the C-groove on the product.
- ▶ Position the sensor bracket.
- ▶ Install the sensor bracket on the product by tightening the corresponding grub screw.
- ▶ Slide the sensor into the sensor bracket.
- ▶ Clamp the sensor by tightening the second grub screw.

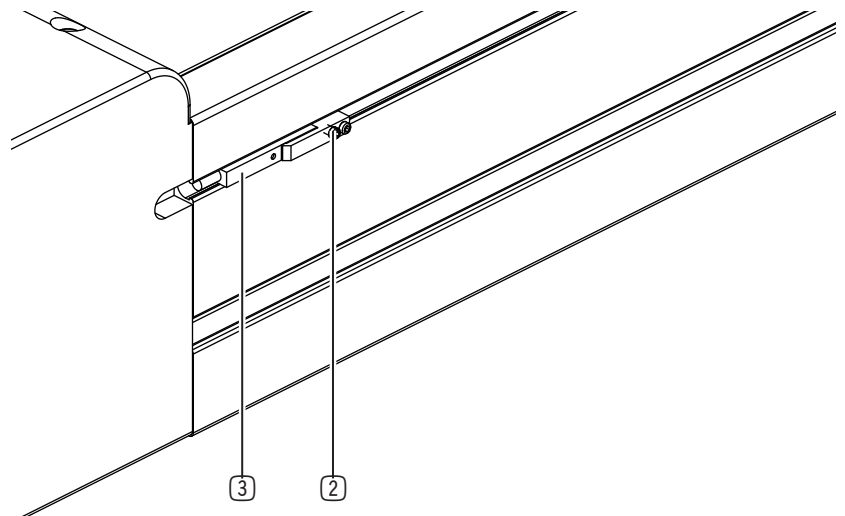
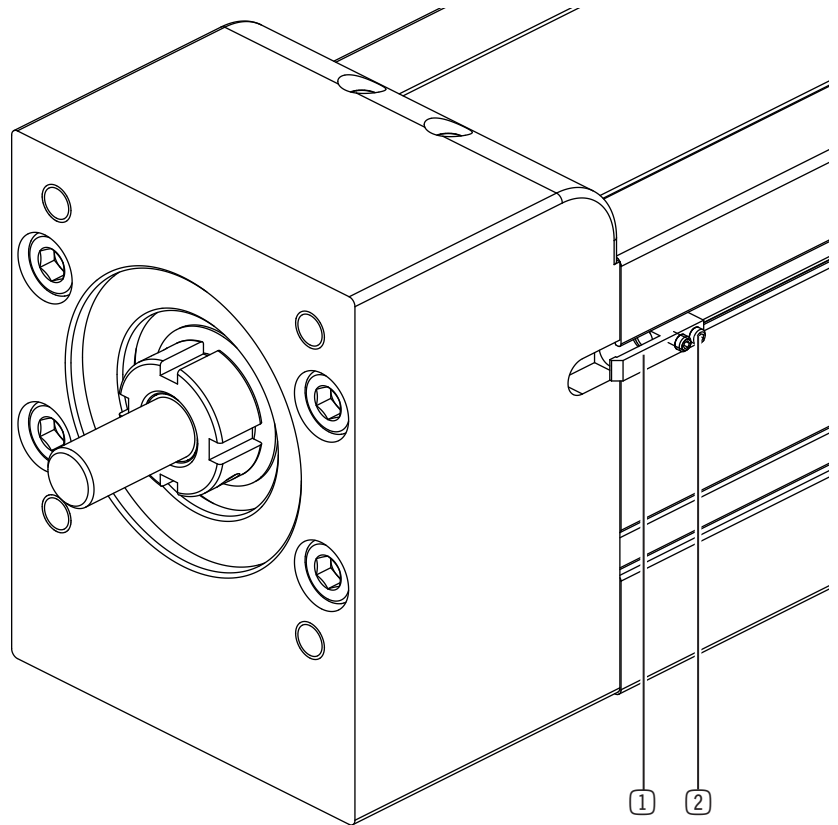

- ① Sensor bracket
- ② Set Screw
- ③ Sensor

11.2 Installing the drive

INFORMATION



The number of required adapter plates can vary depending on the drive.
The following sections depict examples of product variants.

11.2.1 Installing the motor

- ▶ Put the clamping hub on the spindle.
- ▶ Tighten the clamping screw in the clamping hub.
 - ▶ Observe the tightening torque listed in the table.
- ▶ Put the elastomer ring gear on the clamping hub.
- ▶ Position the adapter plate for the drive train on the end block so that the holes align.
- ▶ Install the adapter plate by using the mounting screws.

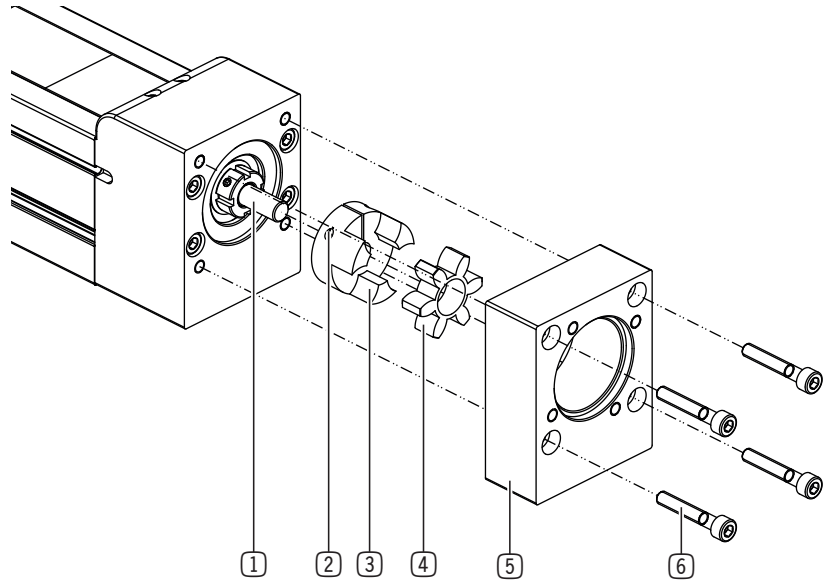

- ① Spindle
- ② Clamping screw
- ③ Clamping hub
- ④ Elastomer ring gear
- ⑤ Adapter plate for drive train
- ⑥ Mounting screw

Installation size [mm]	Clamping screw tightening torque [Nm]
40	4
60	8
80	15
120	35

- ▶ Install the adapter plate for the motor on the adapter plate for the drive train.
- ▶ Put the clamping hub on the motor shaft.

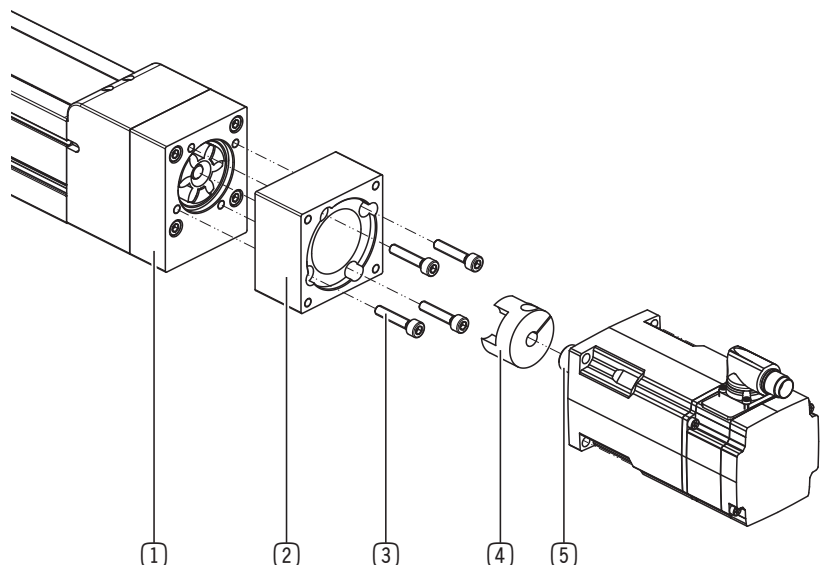

- ① Adapter plate for drive train
- ② Adapter plate for motor
- ③ Mounting screw
- ④ Clamping hub
- ⑤ Motor shaft

► Set a motor shaft protrusion of 0.5 mm.

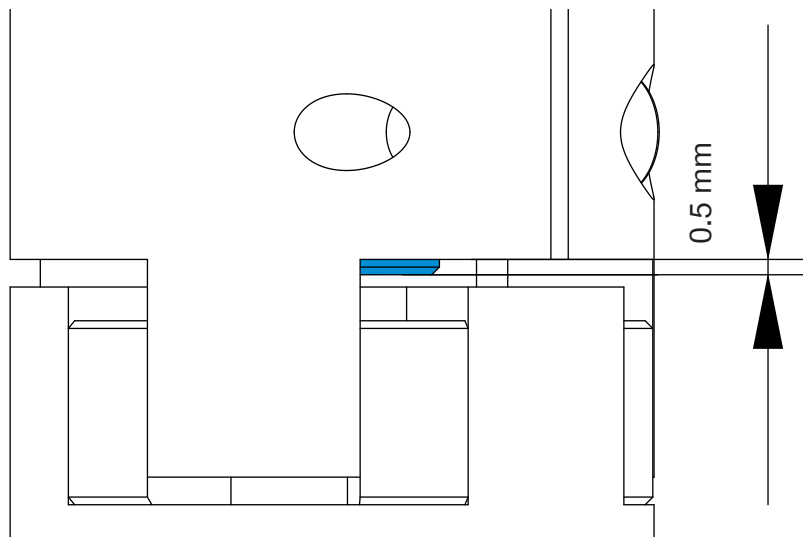

- Tighten the clamping screw in the clamping hub.
 - Observe the tightening torque listed in the table.
- Position the motor on the adapter plate.
- Install the motor to the adapter plate as per manufacturer's information.

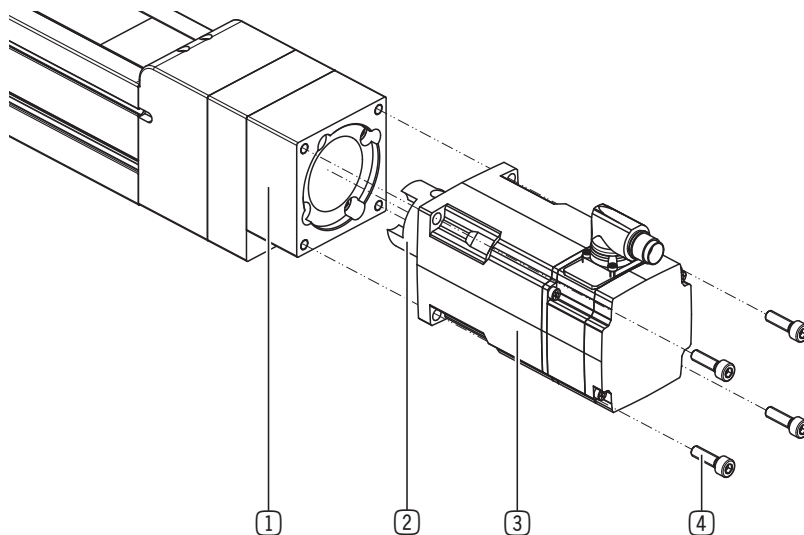

- ① Adapter plate
- ② Clamping hub
- ③ Motor
- ④ Mounting screw

Installation size [mm]	Clamping screw tightening torque [Nm]
40	4
60	8
80	15
120	35

11.3 Installing the customer-specific application

WARNING



Risk of injury and material damage in case of non-compliance

If unsuitable mounting elements are used or if the number of mounting elements is insufficient, the product may tear off as a result of the load.

- ▶ Use suitable mounting screws.
- ▶ Maintain the required minimum number of mounting elements depending on the load.
- ▶ Comply with the permitted tightening torques of the mounting screws.
- ▶ Use threadlocker.

NOTICE



Non-compliance may result in material damage.

▶ If a product variant is being used with more than one carriage, only use centering sleeves in one of the two slides to prevent distortion.

- ▶ Insert the centering sleeves crosswise into the designated fits on the carriage.
- ▶ Position the customer-specific application.
- ▶ Loosely attach the mounting screws.
- ▶ Tighten the mounting screws without distortion.

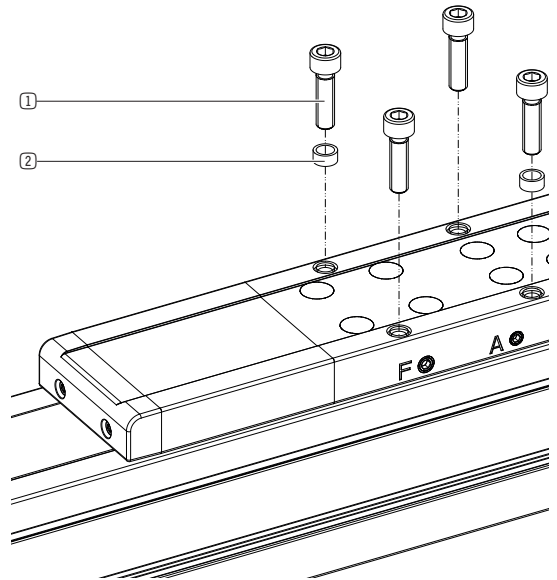

- ① Mounting screw
- ② Centering sleeve

11.3.1 Installing the pneumatic system

INFORMATION



The pneumatics only need to be installed if using the optional clamping element.

- ▶ Remove the grub screws.
- ▶ Mount the screw fitting in the provided connection.
- ▶ Mount the pneumatic hose in the screw fitting.

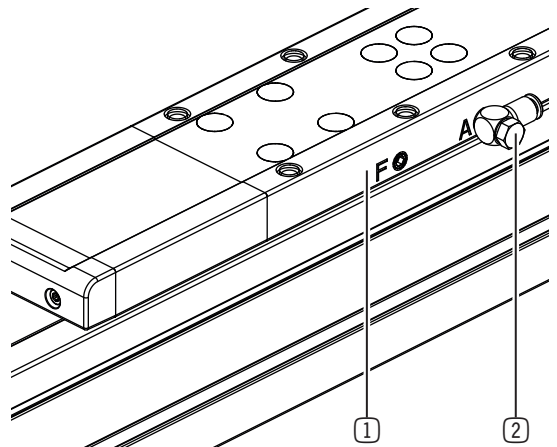

- ① Slides
- ② Screw fitting

11.3.2 Installing the electronics

- ▶ Connect the connecting line for the motor to the drive control unit, including the power supply, motor holding brake and position encoder.

11.3.2.1 Supply with alternating current

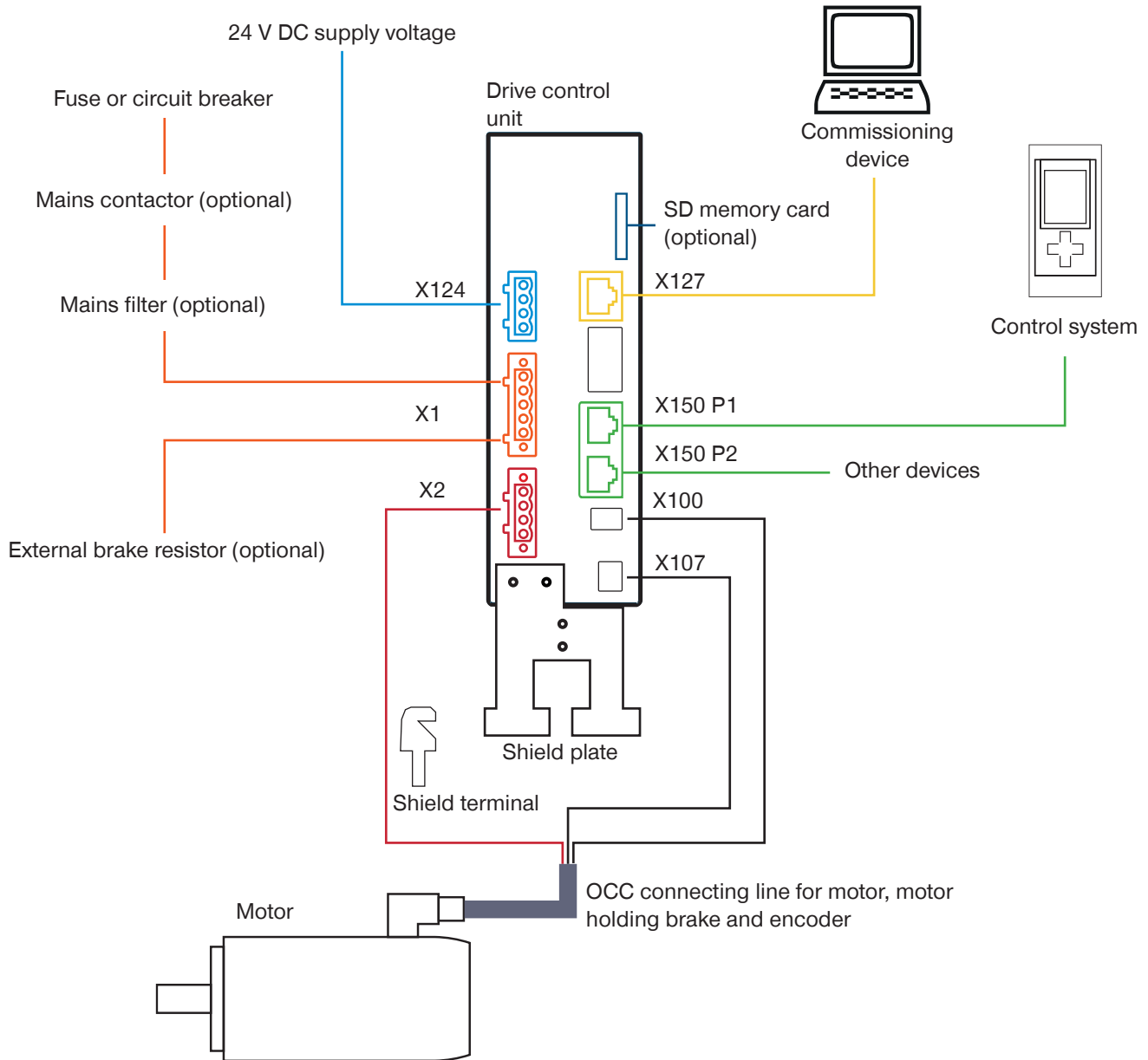

11.3.2.2 Supply with three-phase current

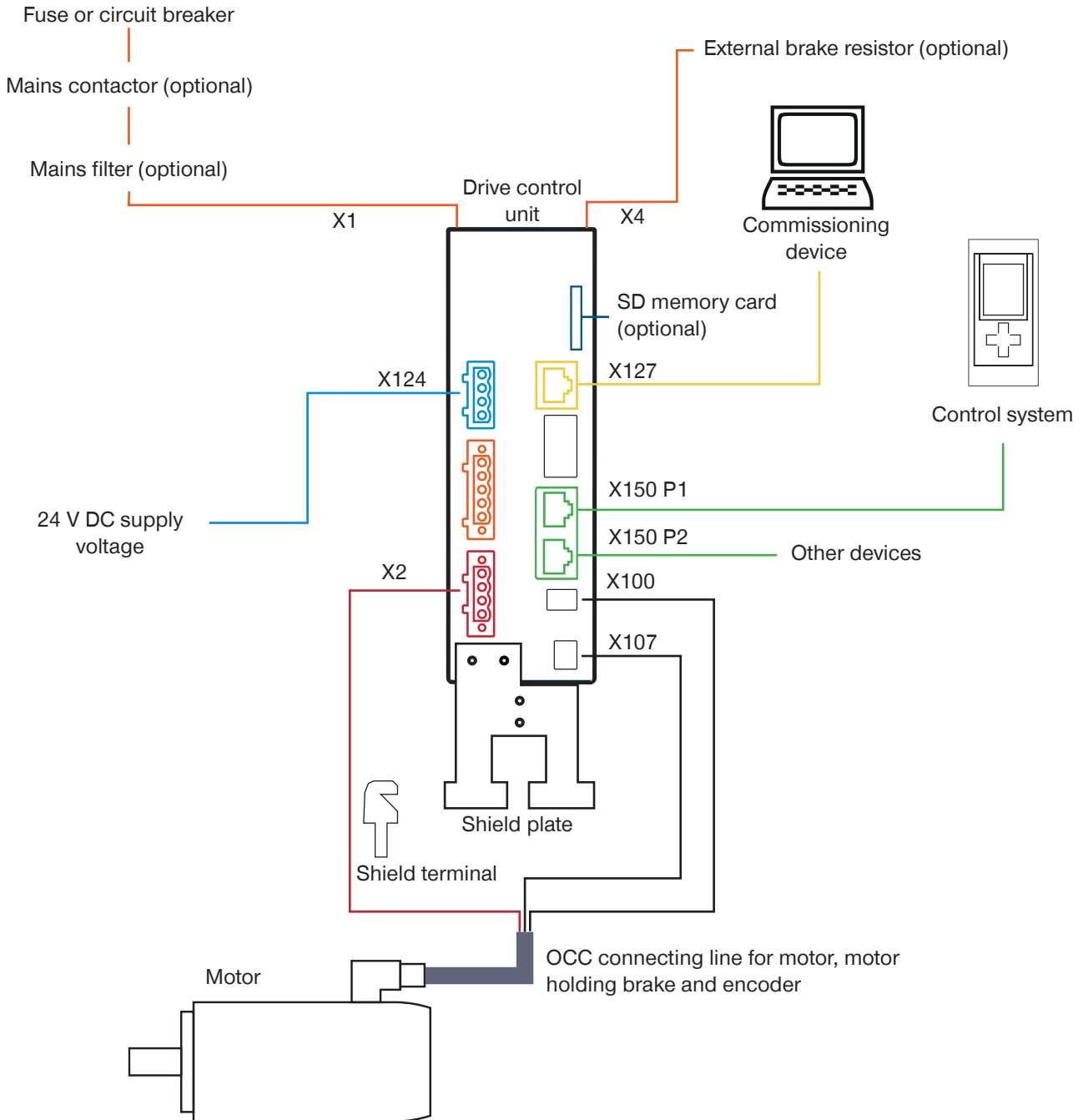

12 Commissioning

WARNING

**Risk of injury from being drawn in or caught**

When the product is moving, limbs or hair can be caught and drawn in.

- ▶ Make sure that there are no parts of the body in the range of movement of the product!

CAUTION

**Risk of injury and material damage in case of non-compliance**

Clamping processes during movement can result in damage to the clamping element. A malfunction resulting from this can lead to injuries.

- ▶ Only clamp in the static state.
- ▶ Never use the clamping element as an emergency brake.

NOTICE

**Material damage due to collision**

The dampers are used to protect the product at low speeds. They are not designed to protect the product completely from damage at a higher speed and/or higher mass.

- ▶ Check the dampers after a strong collision and contact Customer Service.

INFORMATION



- ▶ For more information about the drive control unit, refer to the documentation of the manufacturer.

12.1 Checking operational readiness

- ▶ Check that all components and connections are installed correctly.
- ▶ Check the energy supply.
- ▶ Check all mounting screws for the prescribed tightening torque.

12.2 Preparing for commissioning

INFORMATION



► For information on drive control unit commissioning, refer to the documentation of the manufacturer.

- https://cache.industry.siemens.com/dl/files/329/109754329/att_1122014/v1/S210_QIG_230V_0321_en-US.pdf
- https://cache.industry.siemens.com/dl/files/769/109763769/att_1122021/v1/S210_QIG_400V_0321_en-US.pdf

► Click *Load device as new station (hardware and software)* in the *Online* menu to integrate the drive control unit into the Simatic TIA project.

⇒ The drive control unit was loaded to the project.

► In Project navigation, click *Configuration*.

► Check the setting of the drive control unit, motor and, if necessary, holding brake.

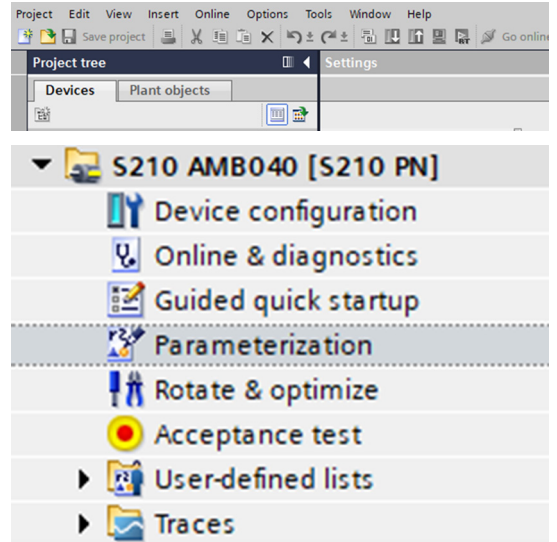

► Select the sense of rotation appropriate to the application.

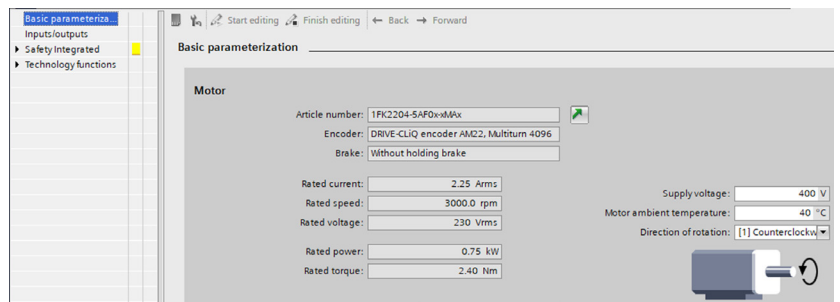

INFORMATION



► Compare the *part number* with the data on the type plate of the motor and drive control unit in the *Motor* and *Encoder* menus.

► If the part numbers do not match, delete the drive control unit by clicking the *Factory settings* icon.

► Then reload the drive control unit to the project.

12.2.1 Device configuration

- ▶ Click *Device configuration* in Project navigation under the drive control unit.
- ▶ Click *<Add telegram>* in *Telegram project planning*.

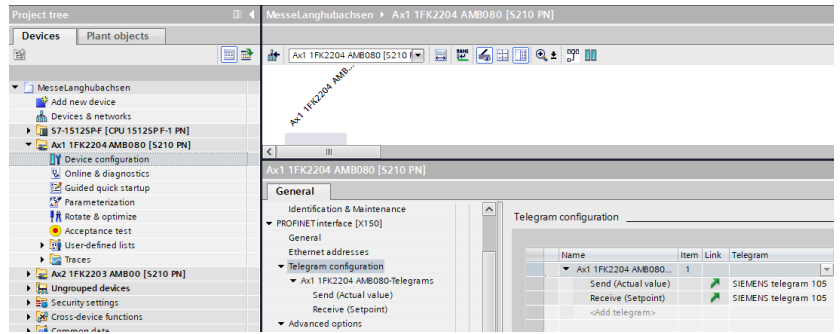

- ▶ Select the *<Add additional telegram torque>* option in the window.
- ⇒ The *Send torque (actual value)* telegram was added.
- ⇒ The *Receive torque (target value)* telegram was added.

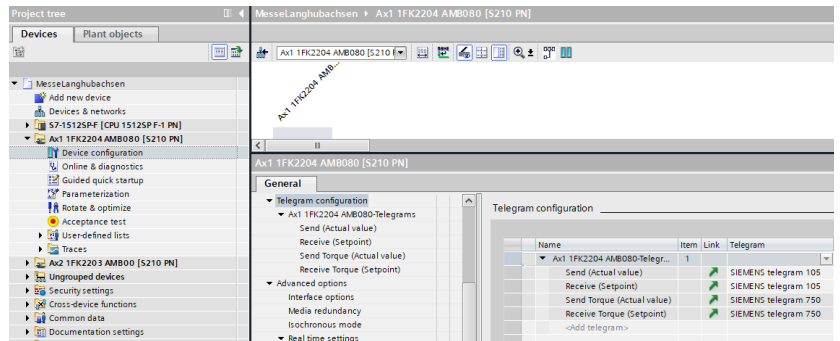

- ▶ Click *Cycle synchronization* in the *More options* window.
- ▶ Activate the *Cycle-synchronous operation* option field.

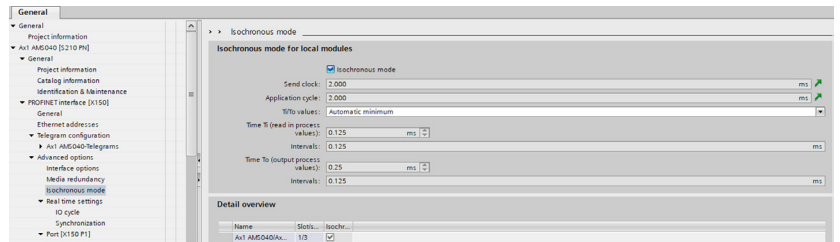

- ▶ Click *Real time settings* in the menu.
- ▶ Enter the desired synchronization settings.

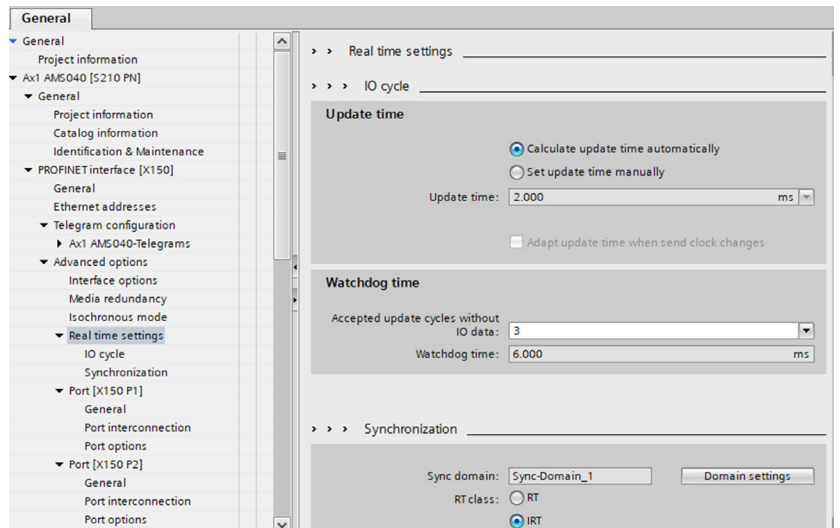

12.2.2 Configuring the drive control unit

- ▶ In Project navigation, click *Turning & Optimization*.

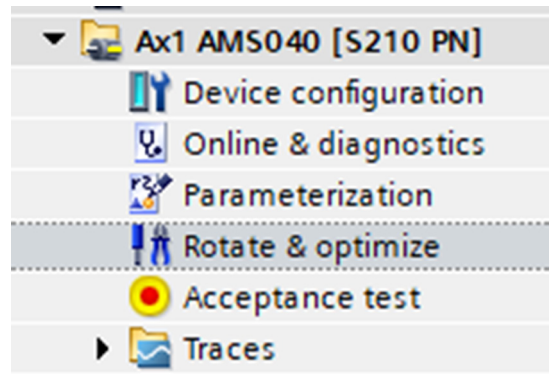

The *One Button Turning* function is used to optimize control parameters.

- ▶ Click *One Button Turning* in the menu.
- ▶ Make sure that the set path limit can be traversed without causing any danger to persons or machinery and no end position is touched.
- ▶ Click the *Start* button.
- ▶ Repeat the process several times with different values for the path limit.
- ▶ Move the product via the control panel.

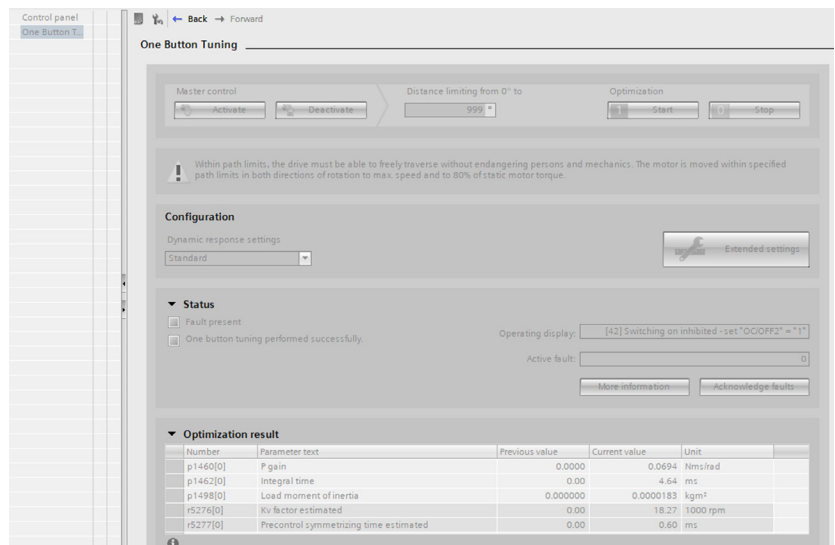

- ▶ Save the settings to the drive control unit by clicking the *Save total device data to non-volatile memory* button.

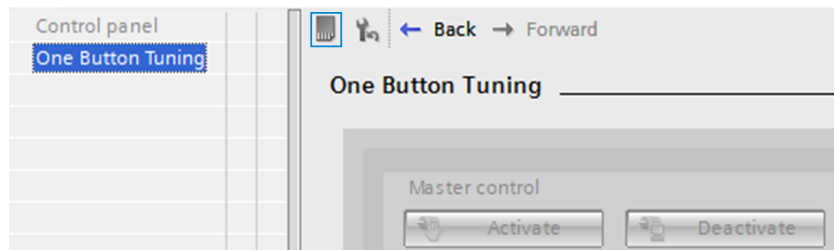

- ▶ In Project navigation, click the drive control unit.
- ▶ Load the configuration to the Simatic-TIA project by clicking the *Load from device* button.

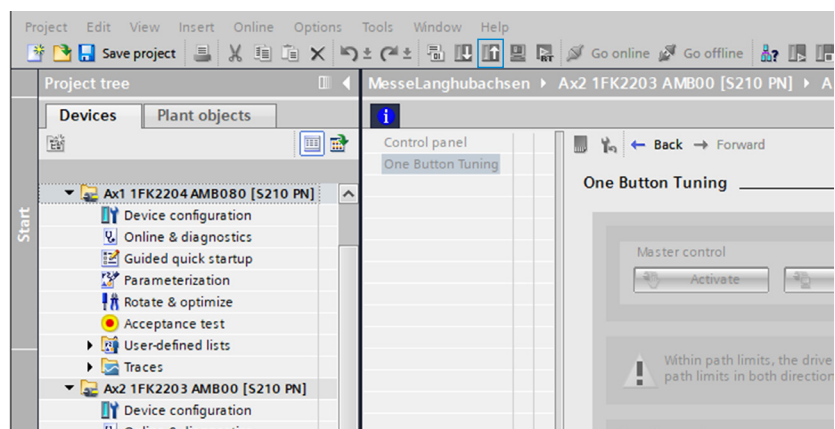

12.3 Making settings in the project

- ▶ In Product navigation, click *Devices & Networks* and select the exact path of the LAN cable in the topology view.
 - ▶ Also make sure that the ports are connected correctly.

- ▶ Then check the settings in the control system and drive control unit in the properties of the device view and adjust if necessary.

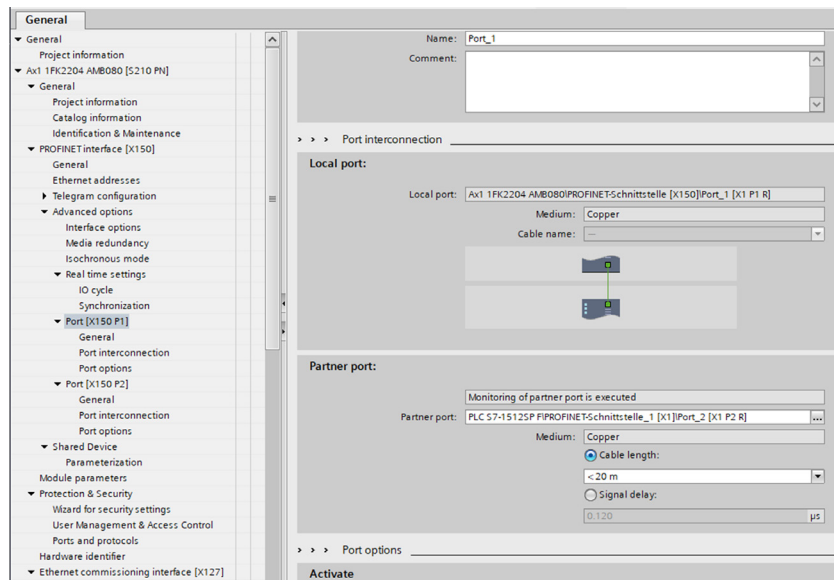
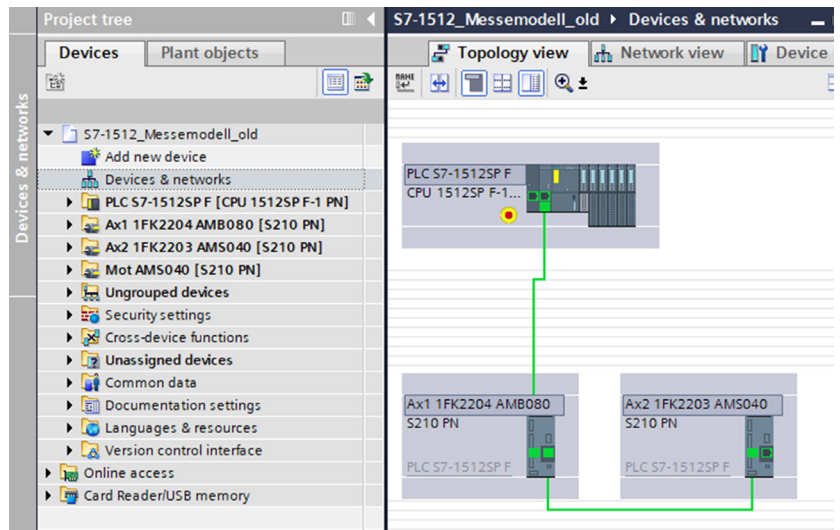

12.4 Adding technology objects

- ▶ In Project navigation, click *Technology objects* and then click *Add new object*.
- ▶ Select the *TO_PositioningAxis* technology object.
 - ▶ It is better to always select the latest version.
 - ▶ Note that this may be limited by the firmware of the CPU and drive control unit.

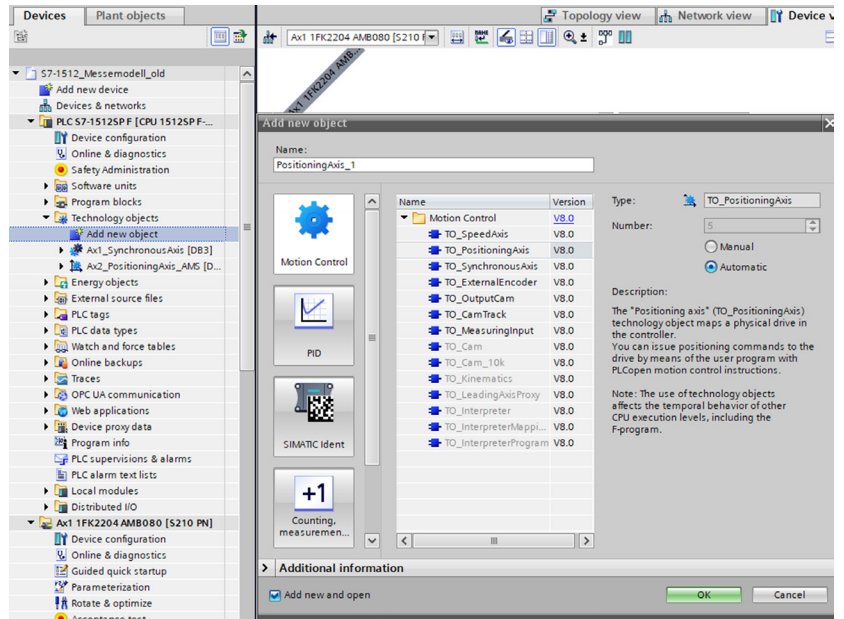

- ▶ Click *Configuration* in the Project navigation under *Technology objects*.
 - ▶ Select the *Drive* option in the *Hardware interface* menu.
 - ▶ Select the corresponding drive.
- ⇒ All points receive a green or blue checkmark.

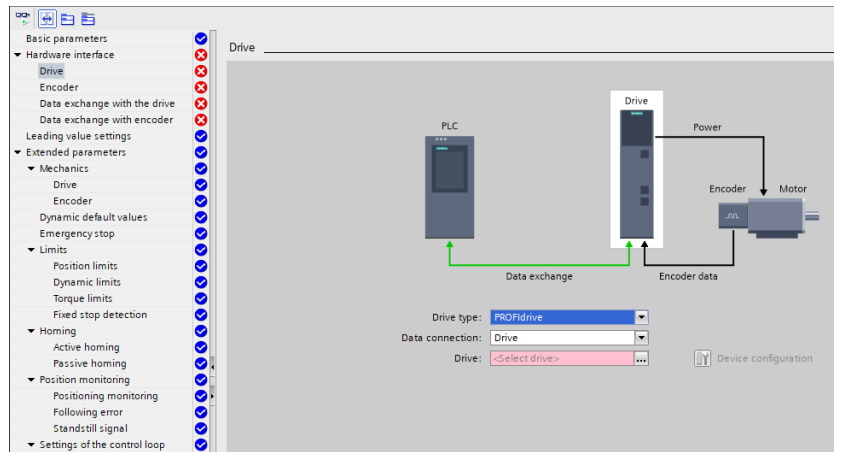

- ▶ Select the *Drive data exchange* option in the *Hardware interface* menu.
- ▶ Activate the *Apply drive values automatically for project planning (offline)* option field.
- ▶ Activate the *Apply drive values automatically for the runtime (online)* option field.
- ▶ Activate the *Torque data* option field.
- ▶ In the *Data connection* drop-down menu, select the *Additional data* option.
- ▶ In the *Additional telegram* drop-down menu, select the telegram of the corresponding drive.

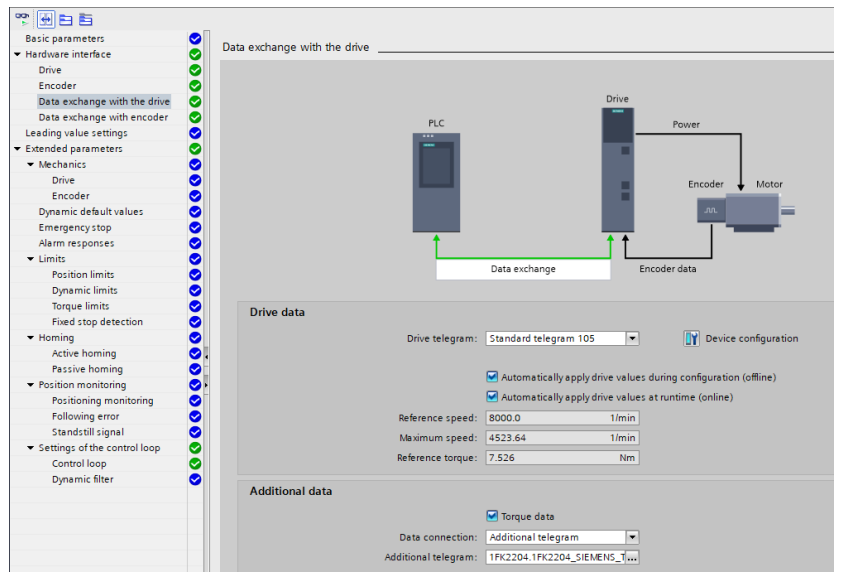

EN / 2024-11-11
DDOC01821 / a

- ▶ In the *Advanced parameters* menu under *Mechanical*, select the *Drive* option.
- ▶ Enter the feed constant as per the table in the *Spindle pitch* field.
- ▶ Enter the drive ratio as per the table in the *Motor revolution quantity* field.

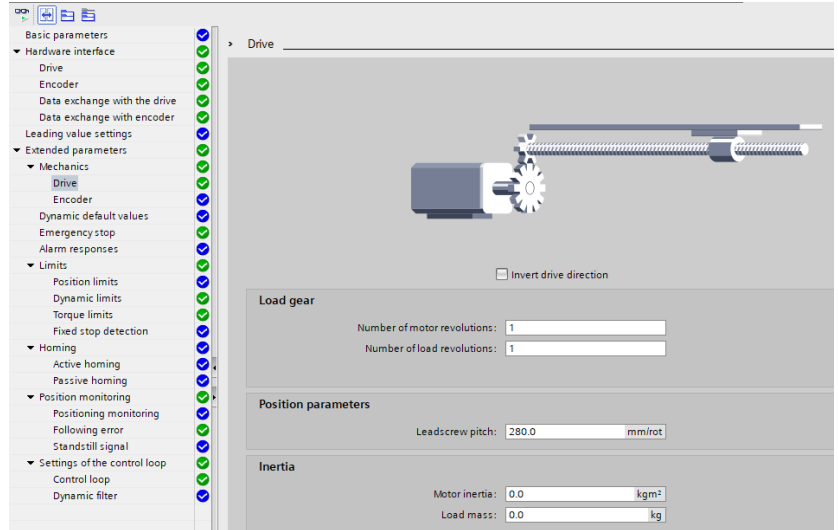

Installation size [mm]	Feed constant [mm]
40	5
40	10
60	5
60	10
60	16
60	30
80	5
80	10
80	20
80	40
120	10
120	20
120	32

- ▶ Click *Dynamic pre-settings* in the *Advance parameters* menu.

The default values entered here can be used by the motion control modules if the identifier for the default is transmitted with the value -1.

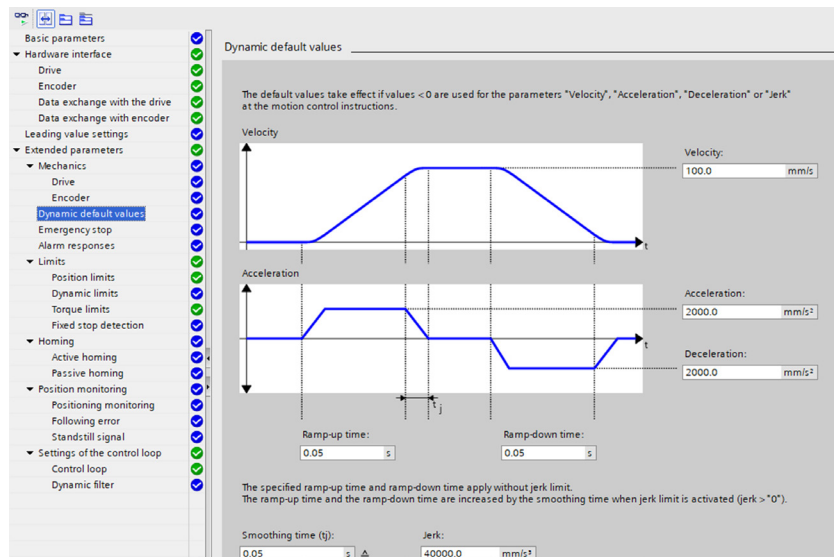

The product is brought to a standstill as quickly as possible with the maximum delay using the emergency stop delay.

- ▶ Click *Emergency stop* in the *Advance parameters* menu.
- ▶ Make sure that the resulting energy does not set the drive control unit to an error state.
- ▶ Either install a brake resistor or provide a longer braking ramp.
- ▶ Enter the emergency stop delay of the product from the data sheet in the *Emergency stop delay* field.

⇒ The emergency stop return time is calculated automatically.

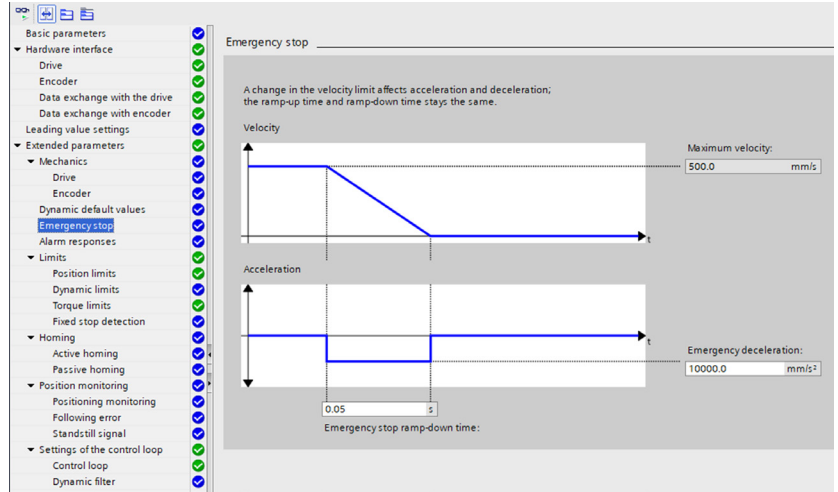

- ▶ In the *Advanced parameters* menu under *Limits*, select the *Position limits* option.
- ▶ Note that the software limit switch can only be used if a valid travel range was set.
- ▶ Make sure that the set end positions are located approx. 15 mm before the actual mechanical end positions.
- ▶ If necessary, place hardware limit switches between the software limit switches and the mechanical end positions.
 - ▶ Note that hardware limit switches are not required, because the product has an absolute encoder.
- ▶ For information on optional accessories and those included in the scope of delivery, refer to our website.
- ▶ Connect the hardware limit switches to the digital input card of the CPU.

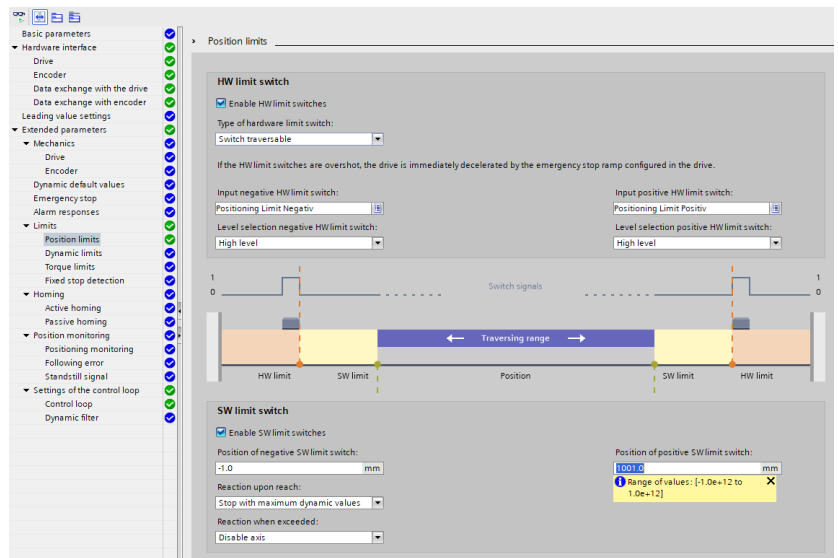

- ▶ In the *Advanced parameters* menu under *Limits*, select the *Dynamic limits* option.
- ▶ Enter the maximum speed of the product from the data sheet in the *Maximum speed* field.
- ▶ Enter the maximum acceleration of the product from the data sheet in the *Maximum acceleration* field.

Dynamic limits

Settings for the dynamic limits

A change in the velocity limit affects acceleration and deceleration; the ramp-up time and ramp-down time stays the same.

Velocity

Maximum velocity: 500.0 mm/s

Acceleration

Maximum acceleration: 10000.0 mm/s²

Maximum deceleration: 10000.0 mm/s²

Ramp-up time: 0.05 s

Ramp-down time: 0.05 s

The specified ramp-up time and ramp-down time apply without jerk limit. The ramp-up time and the ramp-down time are increased by the smoothing time when jerk limit is activated (jerk > 0°).

Smoothing time (sj): 0.05 s

Jerk: 200000.0 mm/s³

Default of extended parameters

Based on the dynamic response limits, the TIA Portal can calculate and set default values of the axis. This calculation influences parameters listed in the following configuration dialogs:

Calculate values

- Dynamic values are influenced in the following configuration dialogs:
- Dynamic default values
- Emergency stop
- Homing
- Position monitoring

12.5 Referencing by Homing

No reference run is required, because the drive is equipped with a multturn absolute encoder.

You only need to set the difference between the axis reference system and the encoder reference system one time.

- ▶ Make the application-specific settings in the *Position monitoring* menu.

- ▶ Select the *Control loop* option in the *Control loop settings* menu.
- ▶ Click the *Apply values to drive* button in the *Positioning control* area.
- ▶ Click *Positioning control in drive (DSC activated)* in the *DSC* area.

12.6 Using the function block

- ▶ Connect the inputs and outputs to the included function block.
- ▶ Select the data block with the application values for the *p_ApplicationValues* pointer.
 - ▶ Do not change the structure of the data block with application values.
- ⇒ Target and actual values can be exchanged with the drive control unit using the data block assigned to *p_ApplicationValues*.
- ▶ Select the data block of the positioning axis technology object for the *p_PositioningAxis* pointer.
- ⇒ The function block communicates with the drive control unit via the technology object.

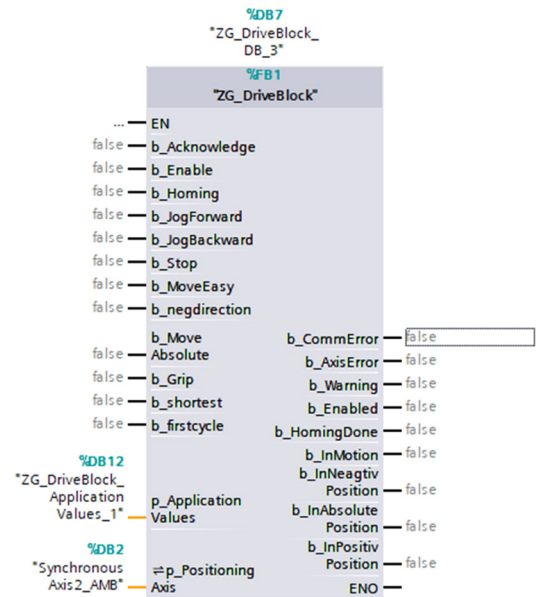

12.7 Function in the function block

12.7.1 Monitoring and switching on

12.7.1.1 b_Enable

The output stage is energized with this variable.

12.7.1.2 b_Enabled

This variable indicates that the output stage is energized.

12.7.1.3 b_InMotion

This variable indicates that the product is in motion.

12.7.1.4 b_CommError

This variable indicates a communication malfunction with the drive.

- ▶ Check the cable of the drive and control system.
- ▶ Check the settings in the device configuration and technology object.

12.7.1.5 b_AxisError

This variable indicates an error with the drive.

- ▶ If necessary, use the *e_StatusWord* and *e_ErrorWord* to determine the cause.
- ▶ Acknowledge the error via *b_Acknowledge*.

INFORMATION



▶ Refer to the document block that was assigned to *p_ApplicationValues* for a detailed description of *e_StatusWord* and *e_ErrorWord*.

- | | |
|---|--|
| <ul style="list-style-type: none"> • <i>e_StatusWord</i> • <i>e_StatusWord.X00_Enable</i> • <i>e_StatusWord.X01_Error</i> • <i>e_StatusWord.X02_RestartActive</i> • <i>e_StatusWord.X03_OnlineStartValuesChanged</i> • <i>e_StatusWord.X04_ControlPanelActive</i> • <i>e_StatusWord.X05_HomingDone</i> • <i>e_StatusWord.X06_Done</i> • <i>e_StatusWord.X07_StandStill</i> • <i>e_StatusWord.X08_PositioningCommand</i> • <i>e_StatusWord.X09_JogCommand</i> • <i>e_StatusWord.X10_VelocityCommand</i> • <i>e_StatusWord.X11_HomingCommand</i> • <i>e_StatusWord.X11_HomingCommand</i> • <i>e_StatusWord.X13_Accelerating</i> • <i>e_StatusWord.X14_Decelerating</i> • <i>e_StatusWord.X15_SWLimitMinActive</i> • <i>e_StatusWord.X16_SWLimitMaxActive</i> • <i>e_StatusWord.X17_HWLlimitMinActive</i> • <i>e_StatusWord.X18_HWLlimitMaxActive</i> • <i>e_StatusWord.X23_MoveSuperimposedCommand</i> • <i>e_StatusWord.X25_AxisSimultion</i> • <i>e_StatusWord.X27_InLimitation</i> • <i>e_StatusWord.X28_NonPositionControlled</i> | <ul style="list-style-type: none"> • <i>e_ErrorWord</i> • <i>e_ErrorWord.X00_SystemFault</i> • <i>e_ErrorWord.X01_CofigFault</i> • <i>e_ErrorWord.X02_UserFault</i> • <i>e_ErrorWord.X03_CommandNotAccepted</i> • <i>e_ErrorWord.X04_DriveFault</i> • <i>e_ErrorWord.X05_SensorFault</i> • <i>e_ErrorWord.X06_DynamicError</i> • <i>e_ErrorWord.X07_CommunicationFault</i> • <i>e_ErrorWord.X08_SW_Limit</i> • <i>e_ErrorWord.X09_HW_Limit</i> • <i>e_ErrorWord.X10_HomingFault</i> • <i>e_ErrorWord.X11_FollowingErrorFault</i> • <i>e_ErrorWord.X12_PositioningFault</i> • <i>e_ErrorWord.X13_PeripheralError</i> • <i>e_ErrorWord.X14_SynchronuousError</i> • <i>e_ErrorWord.X15_AdaptionError</i> |
|---|--|

12.7.1.6 b_Warning

This variable indicates whether there are active warnings.

As soon as the cause of the warning has been eliminated, it is automatically canceled by the product and must not be acknowledged.

INFORMATION



▶ More information about warnings can be found in the instructions of the Sinamics S210.

12.7.1.7 b_Acknowledge

This variable is used to acknowledge errors.

12.7.2 References

12.7.2.1 b_Homing

This variable is used to set the zero point at the current position. This requires that *b_Energized* is set to *true*.

- ▶ Repeat this process when mechanical changes are made between a linear system and motor encoder.

INFORMATION



- ▶ Perform homing once during commissioning.

12.7.2.2 b_HomingDone

This variable indicates that the zero point was set.

12.7.2.3 b_Referenced_internal

This variable is required for internal storage.

NOTICE



Material damage and malfunction in case of non-compliance

- ▶ Do not make any changes to the variable.

Variable	Unit	Description	Source
b_Referenced_internal	Bool	Stored	MCHome.Done

12.7.3 Manual control

12.7.3.1 b_JogForward

The product moves in the positive direction as long as this input is set. This requires that *b_Energized* is set to *true*.

12.7.3.2 b_JogBackward

The product moves in the negative direction as long as this input is set. This requires that *b_Energized* is set to *true*.

12.7.3.3 f_SetJogVelocity

The desired speed for *b_JogForward* or *b_JogBackward* can be entered for this variable.

12.7.4 Easy Move motion

12.7.4.1 b_MoveEasy

The product moves to the *f_SetEasyPositionNeg* or *f_SetEasyPositionPos* position as soon as this variable switches to *true*.

12.7.4.2 b_NegDirection

The product moves in the negative direction when this variable is set to *true* and *b_MoveEasy* is set to *true*.

The product moves in the positive direction when this variable is set to *false* and *b_MoveEasy* is set to *true*.

12.7.4.3 f_SetEasyAccelDecel

The desired acceleration and delay [mm/s²] for *b_MoveEasy* can be entered for this variable.

12.7.4.4 f_SetEasyPositionNeg

This variable defines the negative end position [mm].

12.7.4.5 f_SetEasyPositionPos

This variable defines the positive end position [mm].

12.7.4.6 f_SetEasyVelocity

The desired speed [mm/s] for *b_MoveEasy* can be entered for this variable.

12.7.4.7 f_SetEasyJerk

The desired jerk [mm/s³] for *b_MoveEasy* can be entered with this variable.

12.7.4.8 **b_InNegativPosition**

This variable indicates that the product has moved to the negative end position.

12.7.4.9 **b_InPositivPosition**

This variable indicates that the product has moved to the positive end position.

12.7.5 Absolute movement

12.7.5.1 **b_MoveAbsolute**

The product moves to the *f_SetAbsPosition* position as soon as this variable switches to *true*.

12.7.5.2 **f_SetAbsVelocity**

The desired speed [mm/s] for *b_MoveAbsolute* can be entered for this variable.

12.7.5.3 **f_SetAbsAccelDecel**

The desired acceleration [mm/s²] for *b_MoveAbsolute* can be entered for this variable.

12.7.5.4 **f_SetAbsJerk**

The desired jerk [mm/s³] for *b_MoveAbsolute* can be entered with this variable.

12.7.5.5 **b_InAbsolutePosition**

This variable indicates that the product has moved to the *f_SetAbsPosition* position.

12.7.6 Setting and monitoring

12.7.6.1 **b_FirstCycle**

This variable sets the parameters for a PLC new start or restart. The temporary variables are read once from the non-volatile memory to save cycle time. The control system sets the variable to *true* during the first cycle.

► For further information, refer to the programming example on our website.

12.7.6.2 **b_Stop**

As soon as the variable is set to *true*, all current movement orders are interrupted and prevented from restarting.

12.7.6.3 **f_ActualPosition**

This variable outputs the current position [mm] of the product.

12.7.6.4 **f_ActualVelocity**

This variable outputs the current speed [mm] of the product.

12.7.6.5 **f_ActualTorque**

This variable outputs the current torque [Nm] of the product.

13 Error diagnosis

Error	Possible cause	Measure
Carriage does not move.	• Coupling is slipping.	▶ Check that the coupling is assembled correctly. ▶ Clean the coupling if it is dirty.
	• Ball screw gets stuck or no longer turns.	▶ Please contact Customer Service.
	• Load from customer-specific application is too high.	▶ Reduce the weight of the customer-specific application or accelerate the drive.
	• Error in drive	▶ For more information, refer to the "b_AxisError" section.
Carriage positioned inaccurately.	• Guide has play after a collision, impact or due to extreme load spikes.	▶ Please contact Customer Service.
	• Drive control unit setup incomplete.	▶ Repeat the <i>One Button Turning</i> , refer to the "Configuring the drive control unit" section.
Programmed absolute position changes.	• Coupling is slipping.	▶ Check the tightening torque of the clamping screw and correct it if necessary.
		▶ Check the maximum induced drive torque and reduce it if necessary.
		▶ Clean the coupling if it is dirty.
Sensor does not react.	• Switching distance is too large.	▶ Reset the switching distance.
	• Sensor is defective or there is a cable break.	▶ Replace the limit switch.
	• Signal is not reaching the control system.	▶ Check the supply line to the control system.
Product makes unusual sounds or vibrates in an unusual manner during operation.	• Control parameters are incorrect.	▶ Check the control parameters.
	• Insufficient lubrication.	▶ Re-lubricate the carriage and ball screw.
	• There is bracing in the system.	▶ Check the flatness of the contact surface and customer-specific application and install the product without distortion if necessary.
	• Specified coupling distance was not maintained.	▶ Correct the distance between the clamping hub and expansion hub.
	• Guides are damaged.	▶ Please contact Customer Service.
Control system switches off due to overload.	• There is bracing in the system.	▶ Check the flatness of the contact surface and customer-specific application and install the product without distortion if necessary.
	• Insufficient lubrication.	▶ Re-lubricate the carriage and ball screw.
	• Axis and guides are dirty.	▶ Clean the product. ▶ Check that the guides move freely.
Clamping element does not open or touches.	• No operating pressure or it is too low.	▶ Increase the operating pressure to the value listed in the technical data sheet.
	• The power supply is prevented due to leakage, blockage or crushing of the line.	▶ Check the energy supply for faults.

Error	Possible cause	Measure
Clamping element reacts after a delay.	<ul style="list-style-type: none"> Supply air or exhaust air are insufficient. 	▶ Check the size of the valve.
		▶ Keep the length of the line as short as possible.
		▶ Clean the air filter.
Clamping element does not reach the holding force.	<ul style="list-style-type: none"> Mounting screws are loose. 	▶ Check the tightening torques.
Leakage is audible.	<ul style="list-style-type: none"> Seals have not been applied. 	▶ Open and close the clamping element a min. of 10 times.
	<ul style="list-style-type: none"> Connections are leaking. 	▶ Check all valves and lines and replace if necessary.
	<ul style="list-style-type: none"> Clamping element has reached the end of its service life. 	▶ Please contact Customer Service.

14 Maintenance

WARNING



Risk of injury from crushing

The carriage can sag and cause crushing if not used horizontally or if product variants are used that do not have a clamping element.

- ▶ Secure the carriage against being switched on unintentionally.

NOTICE



Material damage resulting from blowing out with compressed air

Blowing out the product with compressed air can cause malfunctions.

- ▶ Never purge the product with compressed air.

NOTICE



Material damage caused by unsuitable cleaning materials

Liquid and solvent-based cleaning agents can cause malfunctions.

- ▶ Do not clean the product with any cleaning agents that are liquid or contain solvents.

The maintenance interval depends on the respective application. The higher the strain, the more frequently maintenance must be carried out.

- ▶ Note that the product could become damaged under the following circumstances:
 - Dirty environment
 - Improper use and use that does not comply with the performance data
 - Permissible temperature range not observed
- ▶ Have maintenance work that requires disassembly of the product and which is not described in these installation and operating instructions performed by Customer Service only.
- ⇒ Dismantling and reassembling the product without authorization may result in complications, as special installation equipment is required in some cases. Zimmer GmbH accepts no liability for any resulting malfunctions or damage.

14.1 Relubricating the product

INFORMATION



The relubrication work specified applies to each rail carriage.

Rail carriage		
Design size	Interval	Relubrication quantity [cm ³]
40	nach 1000 km	0.2
60	nach 1000 km	0.25
80	nach 1000 km	0.75
120	nach 1000 km	1.5

Ball screw		
Design size	Interval	Relubrication quantity per 1 m stroke [cm ³]
40	After 100 km	5
60	After 100 km	6
80	After 100 km	9
120	After 100 km	15

The product is delivered with initial lubrication. Opposing lubrication points are used to lubricate the same rail carriage. The lubrication interval depends on the load, speed, cycle counter and environmental conditions.

- ▶ Remove the grub screws from the lubrication points.
- ▶ Install the lubricating nipples to the lubrication points.
- ▶ Place the nozzle of the lubrication gun on a lubrication point.
- ▶ Press the nozzle against the lubricating nipple.
- ▶ Inject the required amount of relubrication in several steps.
 - ▶ Initially, only inject a portion of the lubricant.
 - ▶ Move the carriage several times so that the lubricant is distributed.
 - ▶ Repeat the process until reaching the required amount of relubrication.
- ▶ Repeat the process for all lubrication points.

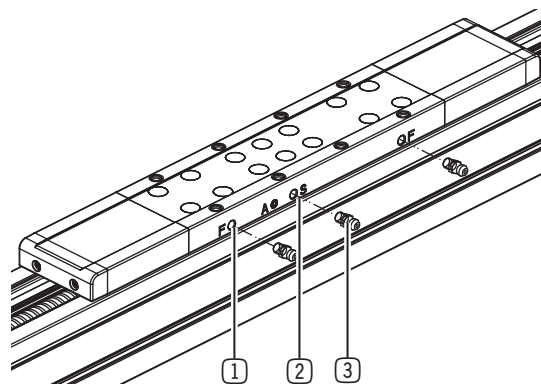

- ① Lubrication point for rail carriage
- ② Lubrication point for ball screw
- ③ Lubricating nipple

14.2 Replacing the cover strip

- ▶ Slightly loosen the clamping screws in the end blocks until the cover strip can be pulled out.
- ▶ Remove the carriage end pieces.
- ▶ Remove the cover strip guides with the integrated pulleys.
- ▶ Pull the cover strip out of the carriage.
- ▶ Cut the new cover strip to the length of the old cover strip.
- ▶ Replace the old cover strip pulleys with new ones.
- ▶ Clean the product and the remaining removed components.
- ▶ Lightly lubricate the new cover strip on both sides.
- ▶ Thread the cover strip into the opening on one side of the carriage until it comes out the other side.
- ▶ Thread the cover strip over the pulleys and through the lower opening of the cover strip guides.

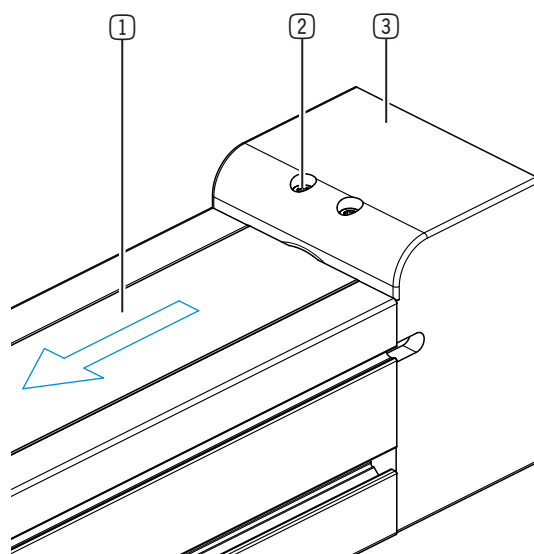

① Cover strip

② Clamping screw

③ End block

- ▶ Tighten the mounting screws of the cover strip guides.
- ▶ Thread the ends of the cover strip into the openings of both end blocks.
- ▶ Install the cover strip to the end blocks by tightening the clamping screws.
- ▶ Install the carriage end pieces.

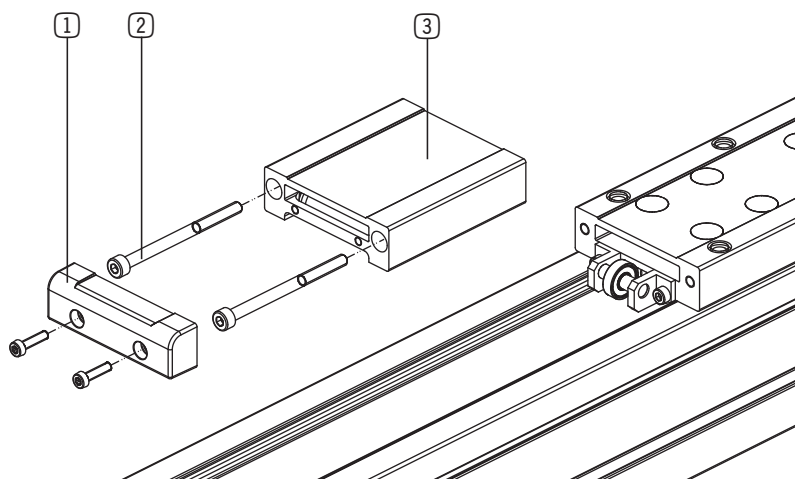

① Carriage end piece

② Mounting screw

③ Cover strip guide

- ▶ Check that the cover strip is seated correctly in the axis profile.
- ▶ Check the installation by moving the carriage to both end positions.
 - ▶ Make sure that the movement meets no resistance.
- ▶ Check again that the cover strip is seated correctly after a few hours of operation.

15 Decommissioning/disposal

INFORMATION



When the product reaches the end of its operational phase, it can be completely disassembled and disposed of.

- ▶ Disconnect the product completely from the power supply.
- ▶ Dispose of the components properly according to the material groups.
- ▶ Comply with the locally applicable environmental and disposal regulations.

16 RoHS declaration

in terms of the EU Regulation 2011/65/EU

Name and address of the manufacturer:

Zimmer GmbH

 Im Salmenkopf
 77866 Rheinau, Germany
 +49 7844 9138 0
 info@zimmer-group.com
 www.zimmer-group.com

We hereby declare that the incomplete machine described below

Product designation: Long-stroke axis with spindle drive

Type designation: AMS

conforms to the requirements of the directive in its design and the version we put on the market.

Michael Hoch

Authorized representative for the compilation of relevant technical documents

Rheinau, Germany, 2024-10-28

(Place and date of issuance)

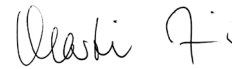

Martin Zimmer
(Legally binding signature)
Managing Partner

17 REACH declaration

In terms of the EC Regulation 1907/2006

Name and address of the manufacturer:

Zimmer GmbH

 Im Salmenkopf
 77866 Rheinau, Germany
 +49 7844 9138 0
 info@zimmer-group.com
 www.zimmer-group.com

REACH stands for **R**egistration, **E**valuation, **A**uthorisation and **R**estriction of **C**hemicals.

A full declaration of REACH can be obtained from the manufacturer due to the duty to notify in accordance with Art. 33 of the REACH regulation ("Duty to communicate information on substances in articles").

Michael Hoch

Authorized representative for the compilation of relevant technical documents

Rheinau, Germany, 2024-10-28

(Place and date of issuance)



Martin Zimmer
(Legally binding signature)
Managing Partner

18 Declaration of Incorporation

In terms of the EU Machinery Directive 2006/42/EC (Annex II 1 B)

Name and address of the manufacturer:

Zimmer GmbH

📍 Im Salmenkopf
77866 Rheinau, Germany

☎ +49 7844 9138 0

✉ info@zimmer-group.com

🌐 www.zimmer-group.com

We hereby declare that the incomplete machine described below

Product designation: Long-stroke axis with spindle drive

Type designation: AMS

conforms to the requirements of the Machinery Directive, 2006/42/EC, Article 2g, Annex VII, b – Annex II, b, in its design and the version we put on the market.

Basic health and safety requirements:

No. 1.1.2, No. 1.1.3, No. 1.1.5, No. 1.3.1, No. 1.3.2, No. 1.3.4, No. 1.3.7, No. 1.3.9, No. 1.5.3, No. 1.5.4, No. 1.6.4, No. 1.7.1, No. 1.7.3, No. 1.7.4

A full list of applied standards can be obtained from the manufacturer.

We also declare that the specific technical documents were produced in accordance with Annex VII Part B of this Directive. We undertake to provide the market supervisory bodies with electronic versions of special documents for the incomplete machine through our documentation department, should they have reason to request them.

The incomplete machine may only be commissioned if it has been ascertained, if applicable, that the machine or system in which the incomplete machine is to be installed satisfies the requirements of Directive 2006/42/EC on Machinery and an EC Declaration of Conformity has been drawn up in accordance with Annex II 1 A.

Kurt Ross

Authorized representative for the compilation of relevant technical documents

Rheinau, Germany, 2024-10-28

(Place and date of issuance)

Martin Zimmer
(Legally binding signature)
Managing Partner