

# AXIS COMPENSATION MODULES

## SERIES ARP

### ▶ PRODUCT ADVANTAGES

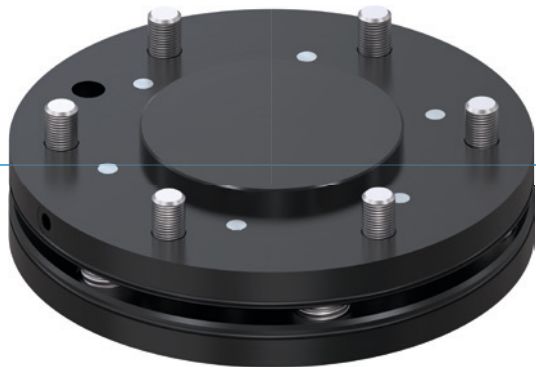

#### ▶ Lockable centre placement

When moving your robot, you can fix the equalizer in place so that uncontrolled movements of the workpiece do not take place

#### ▶ Extremely flat design

This structure reduces the moment load for your robot to a minimum and makes it possible to use smaller and more affordable sizes

#### ▶ Variable balancing force and moment

Adjust the equaliser to your handling weight by mounting a spring package based on desired rigidity

### ▶ THE BEST PRODUCT FOR YOUR APPLICATION



#### ▶ Our products welcome the challenge!

Extreme conditions, all over the world—our tried and tested components and systems give you endless possibilities.

Find the best product for your specific use:

[www.zimmer-group.com](http://www.zimmer-group.com)

## ► BENEFITS IN DETAIL

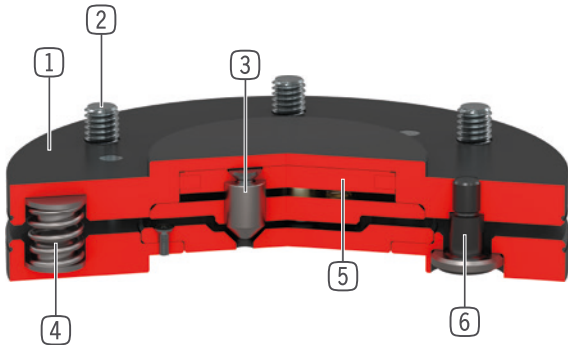

- ① **Robust, lightweight housing**  
- Hard-coated aluminum alloy
- ② **Robot flange**  
- partial mounting circle in accordance with EN ISO 9409-1
- ③ **Locking**  
- 3 locking pistons  
- nitrated steel
- ④ **Spring package**  
- version size 63, stronger one is available  
- version size 100, 3 springs can be removed
- ⑤ **Locking drive**  
- single-acting pneumatic cylinder
- ⑥ **Guiding bolts with ball cup**

## ► TECHNICAL DATA

Installation size	Connecting flange according EN ISO 9409-1	Deflection horizontal +/-	Deflection vertical +/-
		[mm/°]	[mm/°]
AR40P	TK 40	2 / 1	2 / 1
AR50P	TK 50	2 / 1	2 / 1
AR63P	TK 63	2 / 1	2 / 1
AR80P	TK 80	2 / 1	2 / 1
AR100P	TK 100	2 / 1	2 / 1
AR125P	TK 125	2 / 1	2 / 1
AR160P	TK 160	2 / 1	2 / 1

## ► FURTHER INFORMATION IS AVAILABLE ONLINE



All information just a click away at: [www.zimmer-group.com](http://www.zimmer-group.com). Find data, illustrations, 3D models and operating instructions for your installation size using the order number for your desired product. Quick, clear and always up-to-date.

# AXIS COMPENSATION MODULES

## INSTALLATION SIZE AR63P

### ▶ PRODUCT SPECIFICATIONS



#### ▶ Variable installation position

Shows the maximum handling weight depending on acceleration and lever arm. Does not replace the technical design.

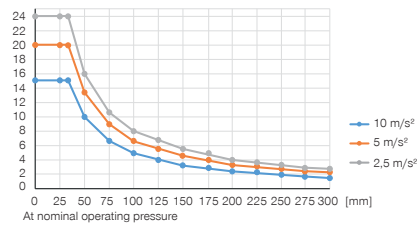

#### ▶ Forces and moments

Shows static forces and moments which may impact on the axis compensation module.

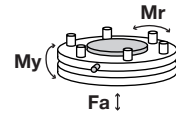

Mr [Nm]	300
My [Nm]	300
Fa [N]	1500

#### ▶ Spring Pack 1 (pre-assembled)

Deviation force horizontal [FH] and vertical [FV] vs the pressure

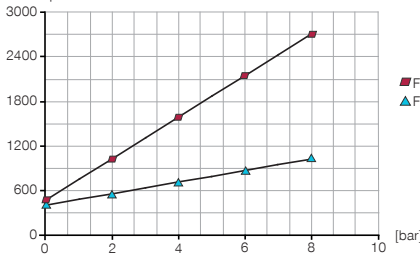

#### ▶ Spring Pack 1 (pre-assembled)

Deviation moment axial [My] and radial [Mr] vs the pressure

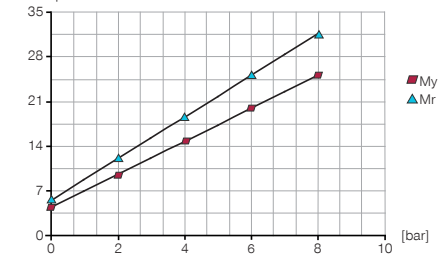

#### ▶ Spring Pack 2

Deviation force horizontal [FH] and vertical [FV] vs the pressure

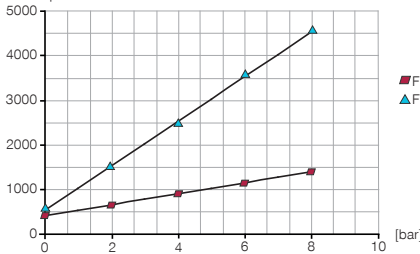

#### ▶ Spring Pack 2

Deviation moment axial [My] and radial [Mr] vs the pressure

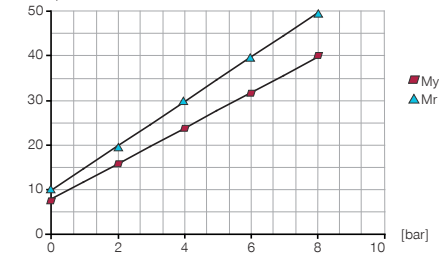

### ▶ INCLUDED IN DELIVERY

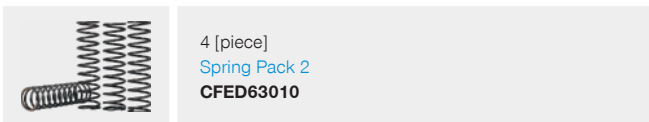
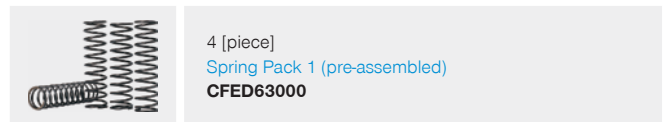
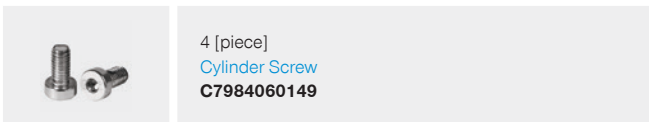

### ▶ RECOMMENDED ACCESSORIES



**WVM3**  
Angled Fittings - Barb Style Connection



**GVM3**  
Straight Fittings - Barb Style Connection

Order no.	▶ Technical data
Connecting flange according EN ISO 9409-1	TK 63
Installation Height [mm]	24
Horizontal deviation +/- [mm]	2
Horizontal deviation +/- [°]	1
Vertical deviation +/- [mm]	2
Vertical deviation +/- [°]	1
Centering force when locking [N]	600
Repetition accuracy Horizontal +/- [mm/°]	0.05
Repetition accuracy Vertical +/- [mm/°]	0.05
Air volume per cycle [cm³]	3.6
Operating pressure [bar]	1 ... 8
Nominal operating pressure [bar]	6
Operating temperature [°C]	5 ... +80
Moment of inertia [kgcm²]	2.8
Weight [kg]	0.39

