

# 3-JAW CONCENTRIC GRIPPERS

## SERIES GD

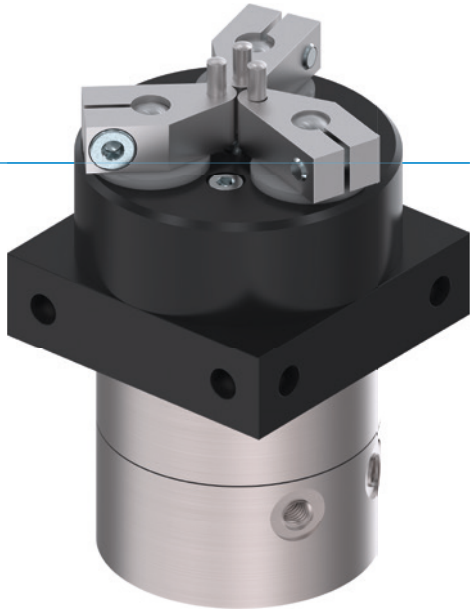

### ▶ PRODUCT ADVANTAGES



#### “The flexible”

- ▶ **Largest stroke in small installation space**  
You can cover numerous application variants with just one gripper type
- ▶ **Gripper jaws included in the delivery**  
Reduces your design effort, manufacturing costs and setup time
- ▶ **Smooth stroke configuration**  
Using the optionally available stroke limit, you can customise the stroke to your application, even stroke sensing is possible

### ▶ SERIES CHARACTERISTICS

Installation size	
GDXX	
 <b>10 million maintenance-free cycles (max.)</b>	●
 <b>Inductive sensor</b>	●
 <b>IP40</b>	●



## ► BENEFITS IN DETAIL

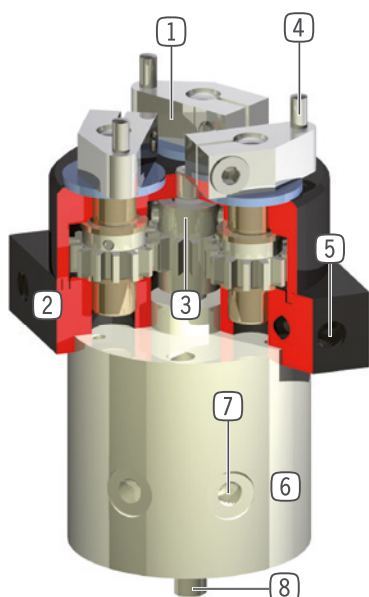

- ① **Gripping movement on rotation**
  - for various workpiece diameters
- ② **Robust, lightweight housing**
  - Hard-coated aluminum alloy
- ③ **Planetary transmission**
  - synchronized the movement of the gripper jaws
- ④ **Standard pins serve as gripper jaw**
- ⑤ **Mounting and positioning**
  - mounting possible from several sides for versatile positioning
- ⑥ **Drive**
  - double-acting pneumatic cylinder
- ⑦ **Energy supply**
  - possible radial and axial
- ⑧ **Shaft projection**
  - for accessory assembly e.g. sensors

## ► TECHNICAL DATA

Installation size	Stroke [°]	Gripping moment [Nm]	Weight [kg]	IP class
GD1	130	0,12	0.08	IP40
GD10	180	1	0.51	IP40
GD50	120	9	2.7	IP40

## ► FURTHER INFORMATION IS AVAILABLE ONLINE



All information just a click away at: [www.zimmer-group.com](http://www.zimmer-group.com). Find data, illustrations, 3D models and operating instructions for your installation size using the order number for your desired product. Quick, clear and always up-to-date.

# 3-JAW CONCENTRIC GRIPPERS

## INSTALLATION SIZE GD50

### ▶ PRODUCT SPECIFICATIONS



#### ▶ Forces and moments

Displays static forces and moments that can also have an effect, besides the gripping force.

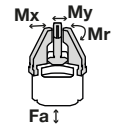

Mr [Nm]	5
Mx [Nm]	5
My [Nm]	4
Fa [N]	100

### ▶ RECOMMENDED ACCESSORIES



#### ENERGY SUPPLY



**GV1-8X8**  
Straight Fittings - Quick Connect Style



**DEV08**  
Quick Exhaust Valve



#### CONNECTIONS / OTHER



**DB50**  
Rotation limiter



**GF50**  
Inquiry for interim position

### ▶ RECOMMENDED ACCESSORY DB50



**NJ12-E2S**  
Inductive proximity switch - Connector M8



**AI-M8X1-53**  
Stop Stroke Adjustment Screws



**AI-M8X1-38**  
Stop Stroke Adjustment Screws



**KAG500**  
Plug-in connector Straight Cable 5m - Socket M8 (female)

### ▶ RECOMMENDED ACCESSORY GF50



**NJ12-E2S**  
Inductive proximity switch - Connector M8



**KAG500**  
Plug-in connector Straight Cable 5m - Socket M8 (female)

Order no.	GD50
Stroke per jaw [°]	120
Gripping diameter in closing min. [mm]	9
Gripping diameter in closing max. [mm]	62
Gripping diameter in opening min. [mm]	21
Gripping diameter in opening max. [mm]	74
Gripping moment in closing [Nm]	9
Gripping moment in opening [Nm]	9
Closing time [s]	0.09
Opening time [s]	0.09
Repetition accuracy +/- [mm]	0.05
Operating pressure min. [bar]	3
Operating pressure max. [bar]	8
Nominal operating pressure [bar]	6
Operating temperature min. [°C]	+5
Operating temperature max. [°C]	+60
Air volume per cycle [cm <sup>3</sup> ]	102
Protection to IEC 60529	IP40
Weight [kg]	2.7

► Technical data

