

# 2-JAW RADIAL GRIPPER

## SERIES GG4000

### ▶ PRODUCT ADVANTAGES

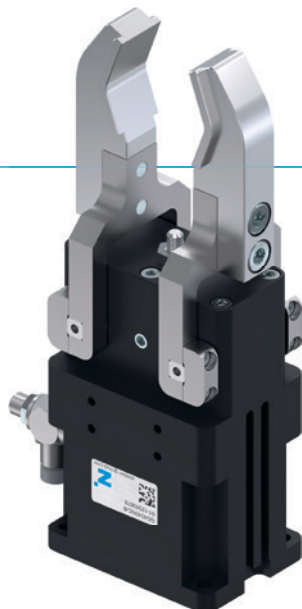

#### “The sealed”

##### ▶ Suitable for use under extreme conditions

The sealed rotation axis guarantees process reliability even under the harshest conditions









##### ▶ Smooth stroke configuration

You can adjust the 180° opening angle to be unique to your application using an adjusting screw

##### ▶ Failure-free continuous operation

Our uncompromising “Made in Germany” quality guarantees up to 10 million maintenance-free cycles

### ▶ SERIES CHARACTERISTICS

| Installation size   | Version |    |
|---|---------|----|
| GG40XX-B  | NC      | SC |
|  Spring closing C                          | •       | •  |
|  High-strength S                           |         | •  |
|  10 million maintenance-free cycles (max.) | •       | •  |
|  Inductive sensor                          | •       | •  |
|  Magnetic field sensor                     | •       | •  |
|  Protected against corrosion               | •       | •  |
|  Purged air                                | •       | •  |
|  IP 64                                     | •       | •  |



## ► BENEFITS IN DETAIL

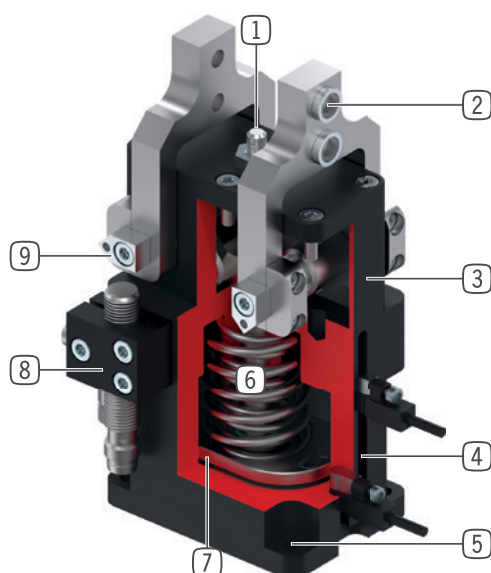

- ① **Stroke adjustment screw**
  - Infinitely adjustable opening stroke
- ② **Removable centering sleeves**
  - individual gripper finger mounting
- ③ **Robust, lightweight housing**
  - Hard-coated aluminum alloy
- ④ **Sensing slot**
  - mounting and positioning of magnetic field sensors
- ⑤ **Mounting and positioning**
  - mounting possible from several sides for versatile positioning
- ⑥ **Integrated gripping force safety device**
  - spring integrated into cylinder as energy storage
- ⑦ **Position sensing**
  - permanent magnet for direct monitoring of piston movement
- ⑧ **Mounting block**
  - mounting for inductive proximity switch
- ⑨ **Sealed rotation point**
  - for use under extreme conditions

## ► TECHNICAL DATA

| Installation size | Stroke per jaw (+/-) | Gripping force | Weight | IP class |
|-------------------|----------------------|----------------|--------|----------|
|                   | [°]                  | [N]            | [kg]   |          |
| GG4032            | 20 - 90              | 430 - 460      | 0,25   | IP64     |
| GG4040            | 20 - 90              | 700 - 800      | 0,5    | IP64     |
| GG4049            | 20 - 90              | 1000 - 1150    | 0,85   | IP64     |
| GG4058            | 20 - 90              | 1650 - 1900    | 1,4    | IP64     |
| GG4072            | 20 - 90              | 1950 - 2700    | 2,45   | IP64     |
| GG4084            | 20 - 90              | 3500 - 4000    | 4,5    | IP64     |

## ► FURTHER INFORMATION IS AVAILABLE ONLINE



All information just a click away at: [www.zimmer-group.com](http://www.zimmer-group.com). Find data, illustrations, 3D models and operating instructions for your installation size using the order number for your desired product. Quick, clear and always up-to-date.

# 2-JAW RADIAL GRIPPER

## INSTALLATION SIZE GG4058

### ▶ PRODUCT SPECIFICATIONS



#### ▶ Gripping force diagram

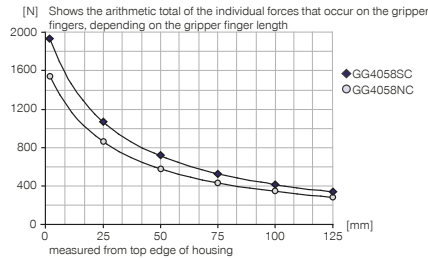

#### ▶ Forces and moments

Displays static forces and moments that can also have an effect, besides the gripping force.

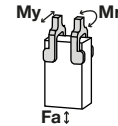

|         |     |
|---------|-----|
| Mr [Nm] | 33  |
| My [Nm] | 33  |
| Fa [N]  | 720 |

#### ▶ Moment of inertia

GG4058NC-B

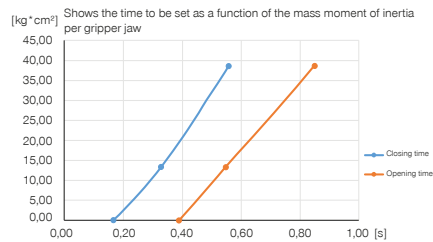

#### ▶ Moment of inertia

GG4058SC-B

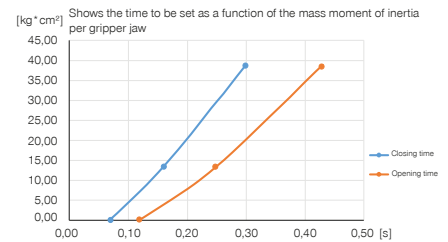

### ▶ INCLUDED IN DELIVERY



4 [piece]  
Centering Disc  
DST11500



2 [piece]  
Flow Control Valves - with Swivel joint  
DRVM5X4

### ▶ RECOMMENDED ACCESSORIES



#### ENERGY SUPPLY



**DSV1-8E**  
Pressure safety valve with quick exhaust



#### SENSORS



**MFS02-S-KHC-P1-PNP**  
Magnetic field sensor straight, cable 0.3 m - M8 connector



#### SENSORS



**KB8-49**  
Mounting block



**MFS01-S-KHC-P2-PNP**  
2-point sensor angled, cable 0.3 m - M8 connector



**MFS02-S-KHC-P2-PNP**  
2-point sensor straight, cable 0.3 m - M8 connector



**NJ8-E2S**  
Inductive proximity switch - Connector M8



**MFS02-S-KHC-IL**  
Position sensor straight, cable 0.3 m - connector M8



**MFS01-S-KHC-P1-PNP**  
Magnetic field sensor angled, cable 0.3 m - M8 connector



| Order no.                                       | ► Technical data |            |
|---|------------------|------------|
|   | GG4058NC-B       | GG4058SC-B |
| Stroke per jaw [°]                              | 90               | 20         |
| Gripping moment in closing at 0° [Nm]           | 46               | 53.5       |
| Gripping moment secured by spring min. [Nm]     | 7                | 15         |
| Gripping force in closing at 0° [N]             | 1650             | 1900       |
| Dead weight of mounted gripper finger max. [kg] | 0.36             | 0.36       |
| Length of the gripper fingers max. [mm]         | 120              | 120        |
| Closing time [s]                                | 0.16             | 0.08       |
| Opening time [s]                                | 0.28             | 0.17       |
| Repetition accuracy +/- [mm]                    | 0.05             | 0.05       |
| Operating pressure min. [bar]                   | 4                | 4          |
| Operating pressure max. [bar]                   | 8                | 8          |
| Nominal operating pressure [bar]                | 6                | 6          |
| Operating temperature min. [°C]                 | 5                | 5          |
| Operating temperature max. [°C]                 | +80              | +80        |
| Air volume per cycle [cm <sup>3</sup> ]         | 86               | 65         |
| Protection to IEC 60529                         | IP64             | IP64       |
| Weight [kg]                                     | 1.4              | 1.4        |

