

2-JAW PARALLEL GRIPPERS

SERIES GP200

▶ PRODUCT ADVANTAGES

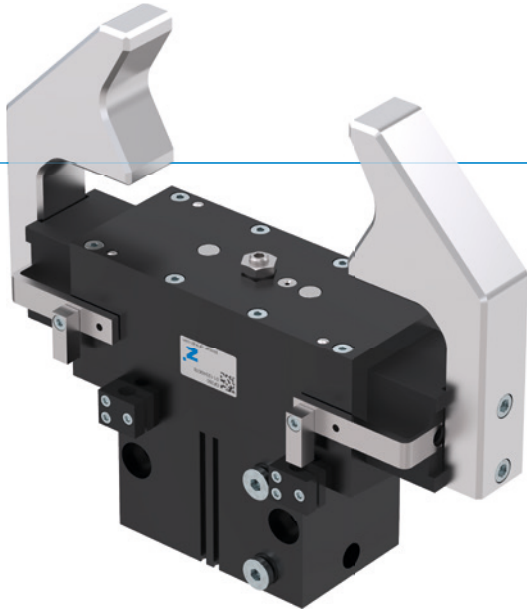

“The variable”

▶ Smooth stroke configuration

An adjusting screw allows you to adjust the stroke to your specific application







▶ Proven technology

We have more than 20 years of proven reliability, which ensures uninterrupted production for you

▶ Dirt protection

Using the scrapers on the guides, you can reliably use the gripper even under the harshest conditions

▶ SERIES CHARACTERISTICS

Installation size	Version				
	GP2XX	-	-99	S	S-99
 Spring closing C	•			•	
 High-strength S				•	•
 10 million maintenance-free cycles (max.)	•		•	•	•
 Inductive sensor	•		•	•	•
 Magnetic field sensor	•		•	•	•
 Purged air	•		•	•	•
 IP40	•		•	•	•



► BENEFITS IN DETAIL

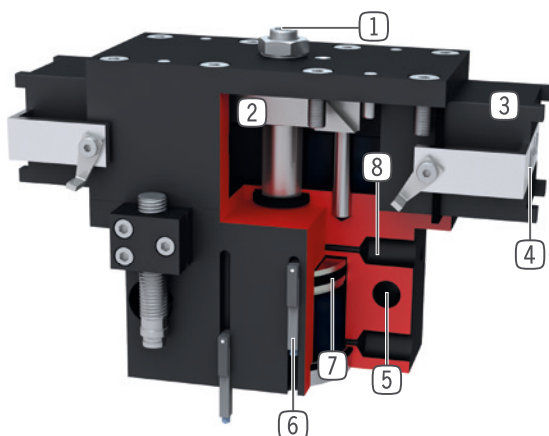

- 1 Stroke adjustment**
 - infinitely adjustable in „open“ movement
 - adjusting screw in delivery
- 2 Wedge hook mechanism**
 - synchronized the movement of the gripper jaws
 - high force transfer
- 3 Square guide**
 - high forces and moments capacity
- 4 Gripper jaw**
 - individual gripper finger mounting
- 5 Mounting and positioning**
 - mounting possible from several sides for versatile positioning
- 6 Sensing slot**
 - mounting and positioning of magnetic field sensors
- 7 Drive**
 - double-acting pneumatic cylinder
- 8 Energy supply**
 - possible from several sides

► TECHNICAL DATA

Installation size	Stroke per jaw [mm]	Gripping force [N]	Weight [kg]	IP class
GP224	6 - 12	170 - 335	0,33	IP40
GP240	8 - 20	510 - 1290	1,2	IP40
GP260	10 - 30	800 - 2480	2,9	IP40
GP280	15 - 40	1690 - 4500	8,3	IP40

► FURTHER INFORMATION IS AVAILABLE ONLINE



All information just a click away at: www.zimmer-group.com. Find data, illustrations, 3D models and operating instructions for your installation size using the order number for your desired product. Quick, clear and always up-to-date.

2-JAW PARALLEL GRIPPERS

INSTALLATION SIZE GP224

▶ PRODUCT SPECIFICATIONS

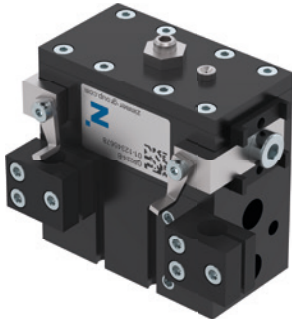

▶ Gripping force diagram

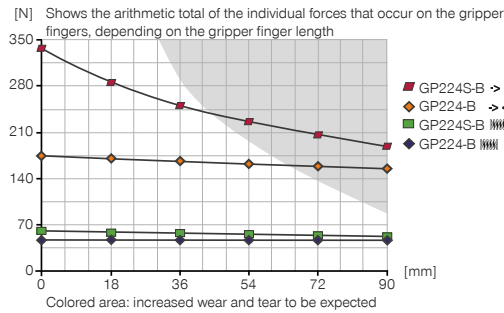

▶ Forces and moments

Displays static forces and moments that can also have an effect, besides the gripping force.



Mr [Nm]	8
Mx [Nm]	15
My [Nm]	8
Fa [N]	250

▶ INCLUDED IN DELIVERY



2 [piece]
Mounting block
KB8K

▶ RECOMMENDED ACCESSORIES



ENERGY SUPPLY



GVM5
Straight Fittings - Quick Connect Style



WVM5
Angled Fittings - Quick Connect Style



DEV04
Quick Exhaust Valve



DSV1-8E
Pressure safety valve with quick exhaust



SENSORS



MFS02-S-KHC-P1-PNP
Magnetic field sensor straight, cable 0.3 m - M8 connector



MFS01-S-KHC-P2-PNP
2-point sensor angled, cable 0.3 m - M8 connector



MFS02-S-KHC-P2-PNP
2-point sensor straight, cable 0.3 m - M8 connector



MFS02-S-KHC-IL
Position sensor straight, cable 0.3 m - connector M8



SENSORS



NJ8-E2S
Inductive proximity switch - Connector M8



MFS01-S-KHC-P1-PNP
Magnetic field sensor angled, cable 0.3 m - M8 connector



CONNECTIONS / OTHER



KAG500
Plug-in connector Straight Cable 5m - Socket M8 (female)



ZE15H7X4
Centering Disc

Order no.	► Technical data			
	GP224-B	GP224-B-99	GP224S-B	GP224S-B-99
Stroke per jaw [mm]	12	12	6	6
Gripping force in closing [N]	170	160	335	335
Gripping force in opening [N]		160		335
Gripping force secured by spring min. [N]	10		35	
Closing time [s]	0.06	0.04	0.06	0.04
Opening time [s]	0.06	0.04	0.06	0.04
Repetition accuracy +/- [mm]	0.05	0.05	0.05	0.05
Operating pressure min. [bar]	5	3	5	3
Operating pressure max. [bar]	8	8	8	8
Nominal operating pressure [bar]	6	6	6	6
Operating temperature min. [°C]	+5	+5	+5	+5
Operating temperature max. [°C]	+80	+80	+80	+80
Air volume per cycle [cm³]	12	12	12	12
Protection to IEC 60529	IP40	IP40	IP40	IP40
Weight [kg]	0.44	0.46	0.44	0.46

