

PINZE PARALLELE A DUE GANASCE

SERIE GP

► VANTAGGI DEL PRODOTTO

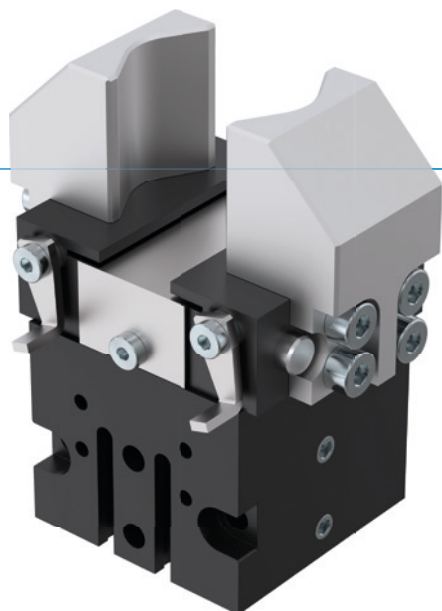

“Il best-seller”

► Sistema sperimentato

L'affidabilità, ormai comprovata da più di 20 anni, vi garantisce una produzione senza guasti







► Tempi ciclo brevissimi

Le coulisse a rulli senza attrito consentono tempi ciclo brevi con conseguente produzione di pezzi elevata

► Utilizzo continuo senza guasti

La nostra qualità senza compromessi “Made in Germany” vi garantisce fino a 10 milioni di cicli senza manutenzione

► CARATTERISTICHE DI SERIE

Dimensioni costruttive	Versione		
	GPXXX	-C/D	S-C/D
 Molla in chiusura C			●
 Forza elevata S			●
 10 milioni di cicli esenti da manutenzione (max.)	●		●
 Sensore induttivo	●		●
 Sensore magnetico	●		●
 IP30	●		●



► I VANTAGGI IN DETTAGLIO

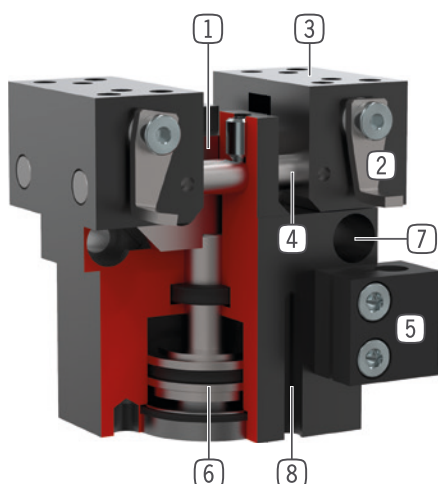

- ① **Meccanismo cuneo-gancio a comando forzato**
 - movimento delle ganasce sincronizzato
 - elevata trasmissione di forza
- ② **Contatto sensore regolabile**
 - per il rilevamento della posizione
- ③ **Ganascia**
 - fissaggio delle ganasce personalizzate
- ④ **Coulisse a rulli**
 - per movimenti ad usura ridotta
- ⑤ **Supporto sensore**
 - fissaggio sensore induttivo
- ⑥ **Azionamento**
 - cilindro pneumatico a doppio effetto
- ⑦ **Fissaggio e posizionamento**
 - in alternativa su più lati, per un montaggio personalizzato
- ⑧ **Scanalatura di rilevamento**
 - fissaggio sensori magnetici

► DATI TECNICI

Dimensioni costruttive	Corsa per ganascia	Forza di presa	Peso	Classe IP
	[mm]	[N]	[kg]	
GP12	3	8,4	0.033	IP30
GP19	4	36	0.081	IP30
GP30	5	94	0.15	IP30
GP45	5	118 - 190	0.255 - 0.3	IP30
GP75	10	220 - 275	0.45 - 0.5	IP30
GP100	8 - 13	450 - 5250	1.3	IP30

► ULTERIORI INFORMAZIONI DISPONIBILI ONLINE



Tutte le informazioni con un clic: www.zimmer-group.com. Con il numero d'ordine potete accedere a dati, disegni, modelli 3D e istruzioni per l'uso del prodotto desiderato per le dimensioni costruttive più adatte a voi. Veloce, semplice e sempre attuale.

PINZE PARALLELE A DUE GANASCE

DIMENSIONI COSTRUTTIVE GP30

► SPECIFICHE PRODOTTO



► Diagramma forza di presa

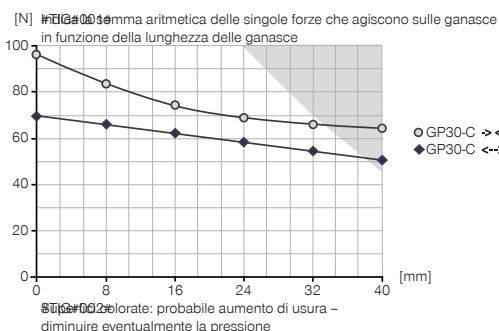

► Forze e momenti

Indica forze statiche e coppie che possono agire in aggiunta alla forza di presa.

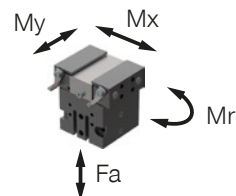

Mr [Nm]	2
Mx [Nm]	2
My [Nm]	2
Fa [N]	80

► ACCESSORI CONSIGLIATI



COMPONENTI DI PRESA



UB30
Kit di ganasce universali alluminio



SENSORISTICA



NJ5-E2SK
Sensori induttivi cavi 0,3 m - Spina M8



ALIMENTAZIONE DI ENERGIA



GVM5
Raccordi filettati lineari



MFS01-S-KHC-P1-PNP
Sensore magnetico angolato, cavo 0,3 m - spina M8



MFS02-S-KHC-P1-PNP
Sensore magnetico lineare, cavo 0,3 m - spina M8



WVM5
Raccordi filettati angolari



MFS01-S-KHC-P2-PNP
Sensore a 2 posizioni angolato, cavo 0,3 m - spina M8



DEV04
Valvole di scarico rapido



MFS02-S-KHC-P2-PNP
Sensore a 2 punti lineare, cavo 0,3 m - spina M8



DSV1-8E
Valvola di ritengo con scarico rapido



MFS02-S-KHC-IL
Sensore di posizione diritto, cavo 0,3 m - connettore M8



SENSORISTICA



KB5
Supporti sensore



COLLEGAMENTI/ALTRO



KAG500
Connettore a spina diritto cavo 5 m - presa M8



NJ5-E2
Sensori induttivi - Cavi 5 m



ZE15H7X4
Disco di centraggio

Numero d'ordine	GP30-D
Corsa per ganaschia [mm]	5
Forza di presa in chiusura [N]	94
Forza di presa in apertura [N]	76
Forza di presa min. assicurata dalla molla [N]	
Tempo di chiusura [s]	0.02
Tempo di apertura [s]	0.02
Ripetibilità +/- [mm]	0.05
Pressione di esercizio min. [bar]	3
Pressione di esercizio mass. [bar]	8
Pressione di esercizio nominale [bar]	6
Temperatura di esercizio min. [°C]	+5
Temperatura di esercizio mass. [°C]	+80
Volume d'aria per ciclo [cm ³]	3.0
Grado di protezione secondo IEC 60529	IP30
Peso [kg]	0.15

► Dati tecnici

