

MANDRINI MOTORIZZATI

HF145-001-001

► VANTAGGI DEL PRODOTTO

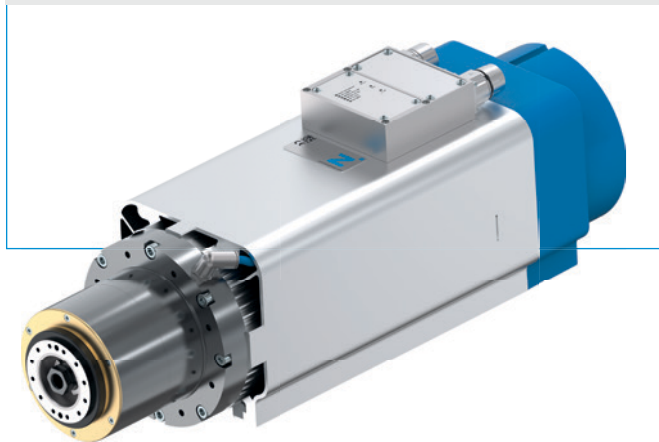

- **Potenza nominale S1: 6 kW**
Coppia nominale S1: 4,9 Nm
Velocità di rotazione max.: 24.000 giri/min
- Raffreddamento ad aria tramite ventilatore elettrico
- Comunicazione IO link
- Concepito come supporto gruppi
- Prestazioni più elevate tramite l'utilizzo di cuscinetti ibridi
- Adatto per la lavorazione di legno, plastica, metalli leggeri e materiali composti

► DOTAZIONE



Pulizia cono dell'interfaccia utensile



IO-Link



Guarnizione a labirinto



Monitoraggio ancoraggio utensili



Aria di tenuta



Controllo numero di giri



Cambio utensile automatico

► OPZIONI



Interfaccia di asse C



Sensore di accelerazione



A regolazione vettoriale / rimessa in ciclo



Pulsante di sbloccaggio utensile manuale



Interfaccia per gruppi



Unità intercambiabile robot

► ACCESSORI



Convertitore di frequenza

Pagina 41



Unità di comando

Pagina 41



Adattatore
Convertitore di frequenza

Pagina 41



Linee elettriche

Pagina 43



Linee di segnali

Pagina 43



Unità intercambiabile
robot

Pagina 44

► DATI TECNICI

► HF145-001-001

Motore asincrono trifase, a 4 poli

Potenza nominale S1 [kW]	6.0
Potenza nominale S1 [Nm]	4.9
Corrente nominale S1 [A]	14.0
Numero di giri nominale	11.780
Numero di giri massimo	24000
Interfaccia utensile	HSK-F63
Tecnologia motore	asincrona
Numero poli	4
Unità di sblocco	Pneumatici
Raffreddamento	Ventilatore elettrico
Peso [kg]	26

► Piano di occupazione

	Collegamenti
A	Sbloccaggio utensile
AZ	Serraggio utensile
KR	Pulizia cono
SPL	Aria di tenuta
XD1	Collegamento di potenza e collegamento di segnale
XG2	Collegamento di segnale

