

TOOL CHANGERS SERIES HWR

▶ PRODUCT ADVANTAGES

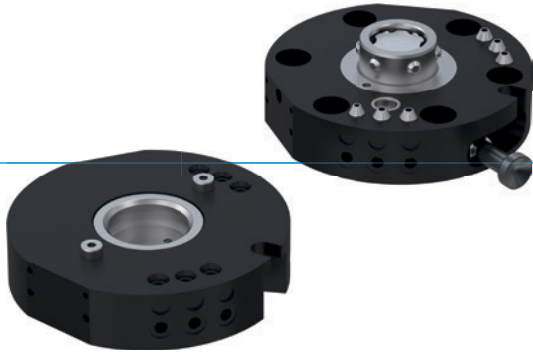

▶ **Change in seconds**

Reduce your start up costs and minimise downtimes by changing your tool in seconds

▶ **Integrated air transfer system**

For supplying pneumatic actuators. Additional media can be transmitted using optional energy elements.

▶ **Replacing with no tools required**

The locking lever fully integrated into the housing makes it possible to replace tools without any additional tools

▶ THE BEST PRODUCT FOR YOUR APPLICATION



▶ **Our products welcome the challenge!**

Extreme conditions, all over the world—our tried and tested components and systems give you endless possibilities.

Find the best product for your specific use:

www.zimmer-group.com

► BENEFITS IN DETAIL

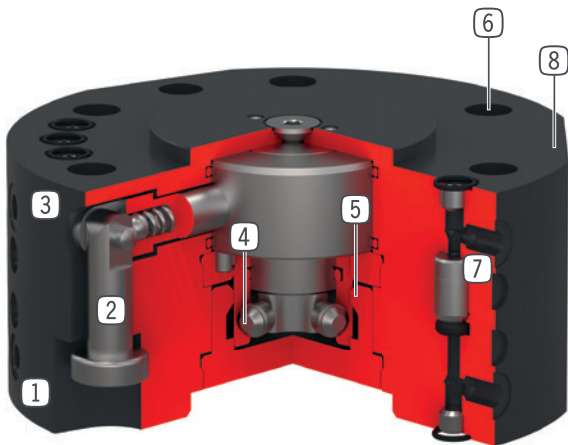

- ① **Loose part**
- for tool side assembly
- ② **Locking lever**
- with spring supported snap in function
- ③ **Fix part**
- For robot side assembly
- ④ **Locking bolt**
- adapted to the clamping sleeve
- ⑤ **Locking stroke**
- re-adjustable via locking sleeve
- ⑥ **Robot flange**
- partial mounting circle in accordance with EN ISO 9409-1
- ⑦ **Integrated air feed-through**
- Air / vacuum transfer
- hoseless control possible
- ⑧ **Mounting for energy element**

► TECHNICAL DATA

Installation size	Connecting flange according EN ISO 9409-1	Pneumatic energy transfer	Electrical energy transfer
		[Quantity]	
HWR63	TK 63	6	optional
HWR80	TK 80	6	optional

► FURTHER INFORMATION IS AVAILABLE ONLINE



All information just a click away at: www.zimmer-group.com. Find data, illustrations, 3D models and operating instructions for your installation size using the order number for your desired product. Quick, clear and always up-to-date.

TOOL CHANGERS

INSTALLATION SIZE HWR80

▶ PRODUCT SPECIFICATIONS



▶ Variable installation position

Shows the maximum handling weight depending on acceleration and lever arm. Does not replace the technical design. [kg]

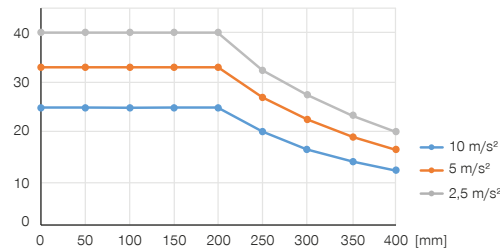

▶ Forces and moments

Shows static forces and moments which may impact on the tool changer when locked.

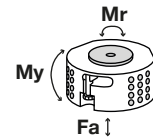

Mr [Nm]	300
My [Nm]	300
Fa [N]	1500

▶ INCLUDED IN DELIVERY



6 [piece]
O-Ring
COR0060100

▶ RECOMMENDED ACCESSORIES



ENERGY SUPPLY



GVM5
Straight Fittings - Quick Connect Style



WVM5
Angled Fittings - Quick Connect Style



CONNECTIONS / OTHER



Energy elements and accessories for tool changer

Order no.	▶ Technical data	
	HWR80F-B	HWR80L-B
Connecting flange according EN ISO 9409-1	TK 80	TK 80
Pneumatic energy transfer [Quantity]	6	6
Flow per connector [l/min]	170	170
Electrical energy transfer	optional	optional
Self locking mechanism when locking	mechanical	mechanical
Locking stroke [mm]	1	
Repetition accuracy in Z [mm]	0.01	0.01
Repetition accuracy in X, Y [mm]	0.02	0.02
Nominal operating pressure [bar]	6	6
Operating temperature [°C]	5 ... +80	5 ... +80
Moment of inertia [kgcm ²]	3.36	2.8
Weight [kg]	0.67	0.48

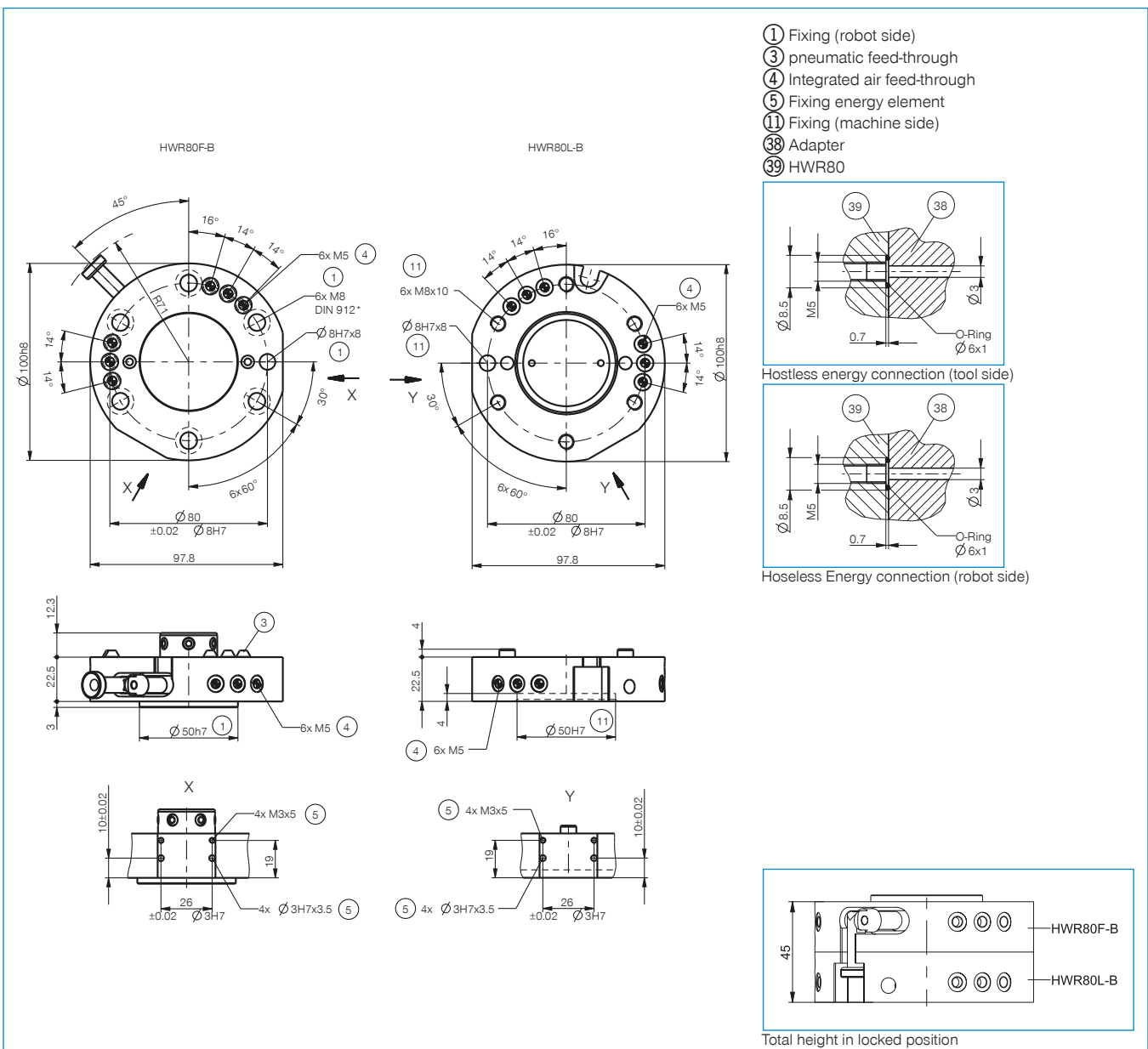

ENERGY ELEMENTS FOR TOOL CHANGER SIZES HWR63 / HWR80

▶ CONNECTION DIAGRAM

