

SYSTÈME DE SERRAGE POINT ZÉRO SPN

SPZ112 - BOULONS DE SERRAGE

► CARACTÉRISTIQUES TECHNIQUES

N° de commande	► Caractéristiques techniques					
	SPZ112BZ10-B	SPZ112BZ12-B	SPZ112BE10-B	SPZ112BE12-B	SPZ112BS10-B	SPZ112BS12-B
Ød1 [mm]	18	18	18	18	18	18
Ød2 [mm]	30	30	29.85	29.85	30	30
Ød3 [mm]	26.8	26.8	26.8	26.8	26.8	26.8
ØD1 [mm]	18	18	18	18	18	18
a [mm]	4.9	4.9	4.9	4.9	4.9	4.9
l [mm]	25.5	25.5	25.5	25.5	25.5	25.5
SW [mm]	20	20	20	20	20	20
T [mm]	5	5	5	5	5	5
M *	M10	M12	M10	M12	M10	M12
Mx **	M8	M10	M8	M10	M8	M10

*ISO 4762

Force de maintien 12.9 maximum [kN]: M6 = 15 ; M8 = 25 ; M10 = 35 ; M12 = 50 ; M16 = 75

Force de maintien 10.9 maximum [kN]: M6 = 12 ; M8 = 20 ; M10 = 30 ; M12 = 40 ; M16 = 60

** ISO 10642

Force de maintien 12.9 maximum. [kN]: M6 = 12 ; M8 = 20 ; M10 = 28 ; M12 = 40 ; M16 = 60

Force de maintien 10.9 maximum. [kN]: M6 = 9,5 ; M8 = 16 ; M10 = 24 ; M12 = 32 ; M16 = 48

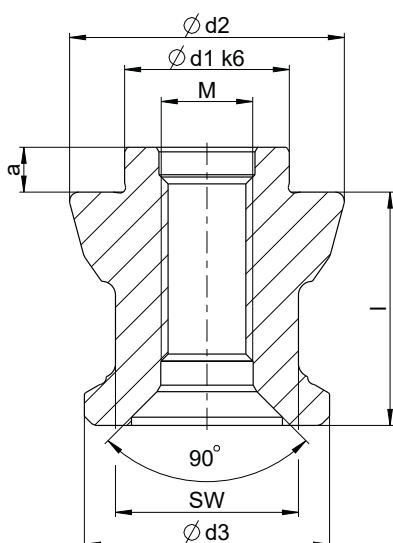
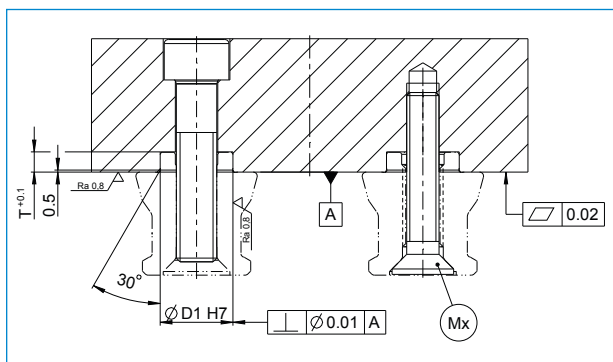

SPZ112BZ10-B
Boulon de centrage

SPZ112BZ12-B
Boulon de centrage

SPZ112BE10-B
Boulon d'entrée

SPZ112BE12-B
Boulon d'entrée

SPZ112BS10-B
Boulon d'épée

SPZ112BS12-B
Boulon d'épée

