

# SISTEMA DI BLOCCAGGIO A PUNTO ZERO SPN

## SPZ138 - PERNI DI BLOCCAGGIO

### ► DATI TECNICI

Numero d'ordine	► Dati tecnici					
	SPZ138BZ12-B	SPZ138BZ16-B	SPZ138BE12-B	SPZ138BE16-B	SPZ138BS12-B	SPZ138BS16-B
Ød1 [mm]	25	25	25	25	25	25
Ød2 [mm]	35	35	34.85	34.85	35	35
Ød3 [mm]	31.2	31.2	31.2	31.2	31.2	31.2
ØD1 [mm]	25	25	25	25	25	25
a [mm]	4.9	4.9	4.9	4.9	4.9	4.9
l [mm]	32	32	32	32	32	32
SW [mm]	22	22	22	22	22	22
T [mm]	5	5	5	5	5	5
M *	M12	M16	M12	M16	M12	M16
Mx **	M10	M12	M10	M12	M10	M12

\*ISO 4762

Forza di tenuta 12.9 mass. [kN]: M6 = 15 ; M8 = 25 ; M10 = 35 ; M12 = 50 ; M16 = 75

Forza di tenuta 10.9 mass. [kN]: M6 = 12 ; M8 = 20 ; M10 = 30 ; M12 = 40 ; M16 = 60

\*\* ISO 10642

Forza di tenuta 12.9 mass. [kN]: M6 = 12 ; M8 = 20 ; M10 = 28 ; M12 = 40 ; M16 = 60

Forza di tenuta 10.9 mass. [kN]: M6 = 9,5 ; M8 = 16 ; M10 = 24 ; M12 = 32 ; M16 = 48

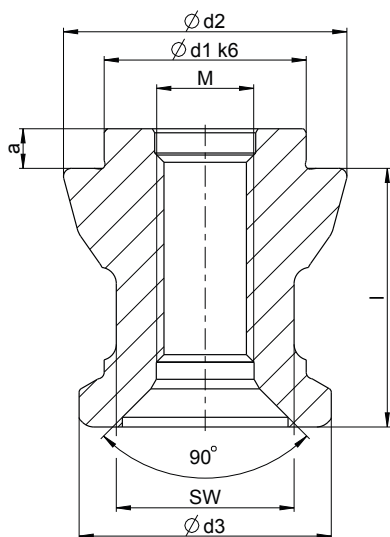
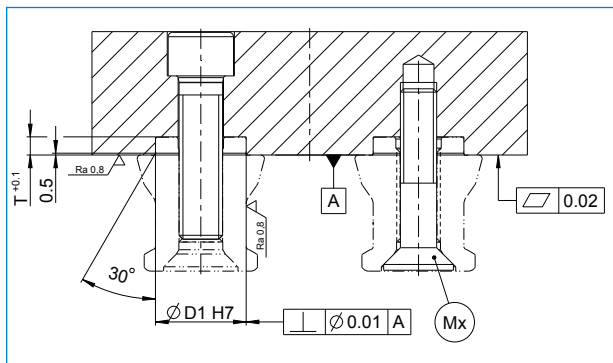

**SPZ138BZ12-B**  
Perno di centraggio

**SPZ138BZ16-B**  
Perno di centraggio

**SPZ138BE12-B**  
Perno di trazione

**SPZ138BE16-B**  
Perno di trazione

**SPZ138BS12-B**  
Perno a ogiva

**SPZ138BS16-B**  
Perno a ogiva

