

# TOOL CHANGERS

## SERIES WWR

### ▶ PRODUCT ADVANTAGES

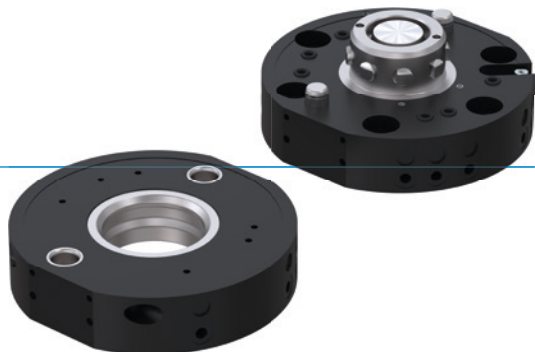

#### ▶ **Secure hold during pressure drop**

The combination of spring loaded and a high gear ratio guarantees them a safe machine

#### ▶ **Extremely flat design**

This structure reduces the moment load for your robot to a minimum and makes it possible to use smaller and more affordable sizes

#### ▶ **Inexhaustible variety of media transfer systems**

No matter which medium you would like to transmit, we will draw from our wealth of experience in implementing projects and find a solution to suit your needs!

### ▶ THE BEST PRODUCT FOR YOUR APPLICATION



#### ▶ **Our products welcome the challenge!**

Extreme conditions, all over the world—our tried and tested components and systems give you endless possibilities.

Find the best product for your specific use:

[www.zimmer-group.com](http://www.zimmer-group.com)

## ► BENEFITS IN DETAIL

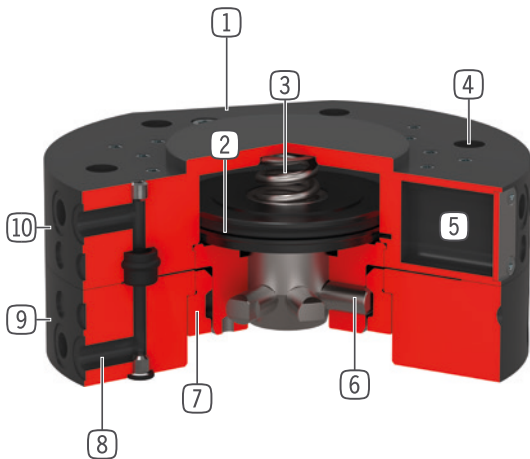

- ① **Mounting for energy element**
- ② **Drive**  
- double-acting pneumatic cylinder
- ③ **Integrated spring**  
- energy storage in case of drop in pressure
- ④ **Robot flange**  
- partial mounting circle in accordance with EN ISO 9409-1
- ⑤ **Piston position sensing**  
- via magnetic field sensor
- ⑥ **Locking bolt**  
- adapted to the clamping sleeve
- ⑦ **Locking sleeve**  
- high moment capacity
- ⑧ **Integrated air feed-through**  
- Air / vacuum transfer  
- hoseless control possible
- ⑨ **Loose part**  
- for tool side assembly
- ① ⑩ **Fix part**  
- For robot side assembly

## ► TECHNICAL DATA

Installation size	Connecting flange according EN ISO 9409-1	Pneumatic energy transfer	Electrical energy transfer
		[Quantity]	
WWR40	TK 40	4	optional
WWR50	TK 50	4	optional
WWR63	TK 63	6	optional
WWR80	TK 80	6	optional
WWR100	TK 100	6	optional
WWR125	TK 125	10	optional
WWR160	TK 160	10	optional

## ► FURTHER INFORMATION IS AVAILABLE ONLINE



All information just a click away at: [www.zimmer-group.com](http://www.zimmer-group.com). Find data, illustrations, 3D models and operating instructions for your installation size using the order number for your desired product. Quick, clear and always up-to-date.

# TOOL CHANGERS

## INSTALLATION SIZE WWR40

### ▶ PRODUCT SPECIFICATIONS



#### ▶ Variable installation position

Shows the maximum handling weight depending on acceleration and lever arm. Does not replace the technical design.

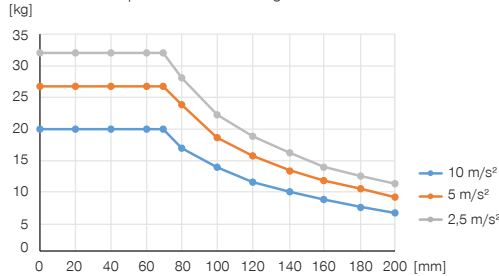

#### ▶ Forces and moments

Shows static forces and moments which may impact on the tool changer.

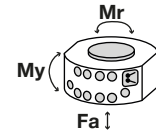

Mr [Nm]	70
My [Nm]	90
Fa [N]	3800

### ▶ INCLUDED IN DELIVERY



4 [piece]  
O-Ring  
COR0025100

### ▶ RECOMMENDED ACCESSORIES



#### ENERGY SUPPLY



**GVM5**  
Straight Fittings - Quick Connect Style



**WVM5**  
Angled Fittings - Quick Connect Style



#### SENSORS



**ZUB088929**  
Piston position sensing



#### SENSORS



**NJR04-E2SK**  
Inductive Proximity Switch Cable 0,3 m - Connector M8



#### CONNECTIONS / OTHER



Energy elements and accessories for tool changer



**ALSR1-40-B**  
Storage station

### ▶ RECOMMENDED ACCESSORY STORAGE STATION



**NJ5-E2**  
Inductive proximity switch - Cable 5 m



**NJ5-E2SK**  
Inductive Proximity Switch Cable 0,3 m - Connector M8

Order no.	▶ Technical data	
	WWR40F-B	WWR40L-B
Connecting flange according EN ISO 9409-1	TK 40	TK 40
Pneumatic energy transfer [Quantity]	4	4
Flow per connector [l/min]	150	150
Electrical energy transfer	optional	optional
Self locking mechanism when locking	mechanical	mechanical
Locking stroke [mm]	0.3	
Repetition accuracy in Z [mm]	0.01	0.01
Repetition accuracy in X, Y [mm]	0.02	0.02
Joining force [N]	50	
Release force [N]	30	
Offset at coupling max. in X,Y [mm]	1.3	1.3
Operating pressure [bar]	4 ... 10	4 ... 10
Nominal operating pressure [bar]	6	6
Operating temperature [°C]	5 ... +80	5 ... +80
Air volume per cycle [cm <sup>3</sup> ]	2.8	
Moment of inertia [kgcm <sup>2</sup> ]	0.3	0.28
Weight [kg]	0.12	0.09

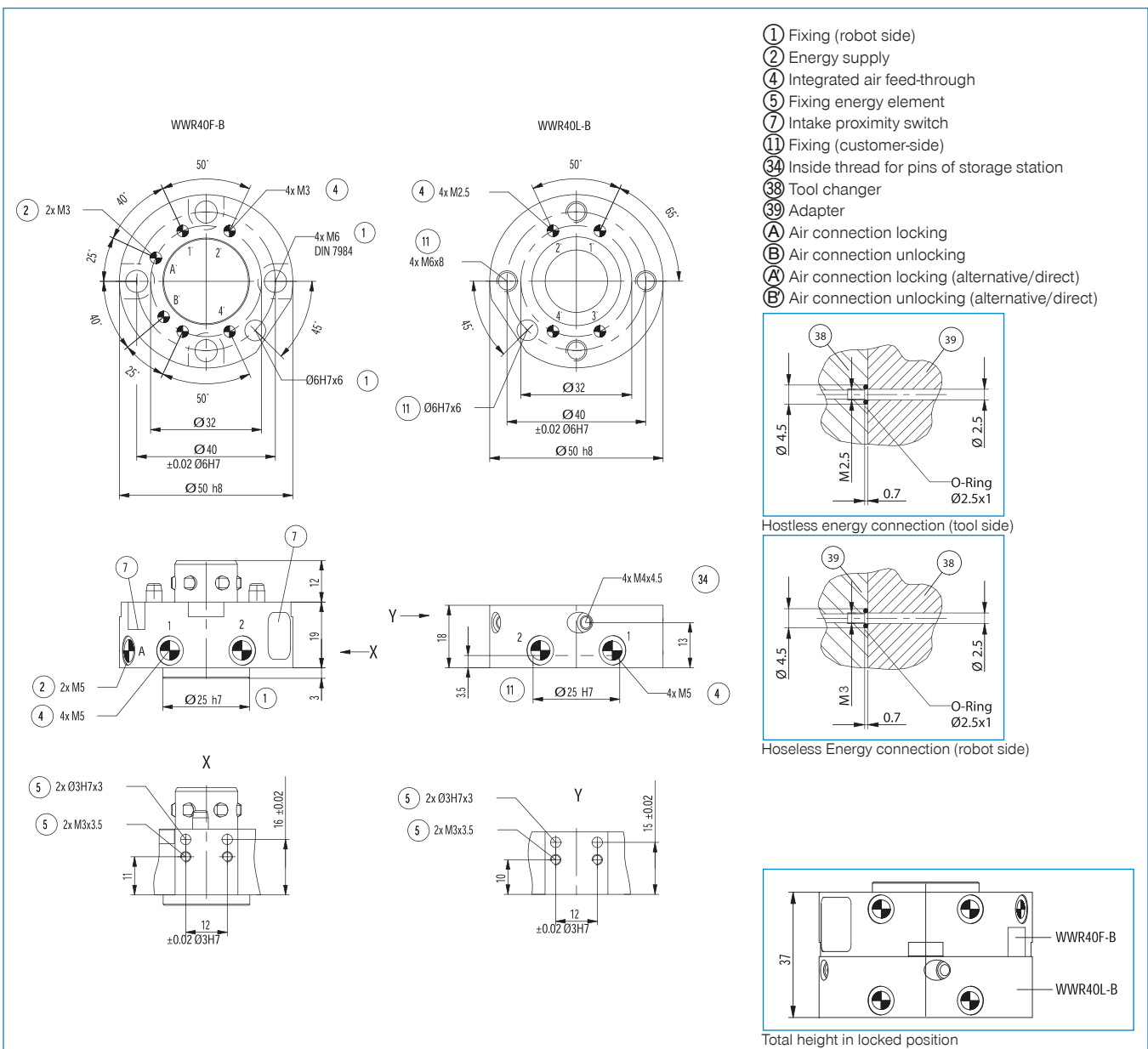

# ENERGY ELEMENTS FOR TOOL CHANGER

## SIZES WWR40 / WWR50

### ▶ CONNECTION DIAGRAM

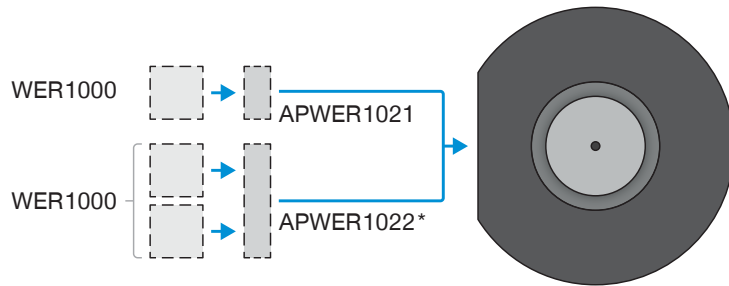

\*when using APWER1022, ZUB152474 must be used to be able to use air connection 4 (only WVM5 possible).