

INSTALLATION AND OPERATING INSTRUCTIONS

2-jaw parallel gripper, electric
GEP5000

3-jaw concentric gripper, electric
GED5000

DDOC00211

THE KNOW-HOW FACTORY

Glossary

Term	Explanation
ActualPosition	Value of the current position of the product [1/100 mm]
Adjust	Starts the travel routing stored in the product to teach the BasePosition and WorkPosition.
BasePosition	Outer jaw position Depending on the application, this can be the base position or the work position.
ControlWord	Activation of the product Only one bit is permitted to be active in ControlWord. The value "0" is also permitted.
DeviceMode	Used to select gripping profiles as well as the additional help modes in the product.
Diagnosis	If an error occurs, outputs a diagnostic code that can be compared with the error list.
DIR	Direction/24 V DC cable connection Depending on the product, this signal is used to move the product.
Error	Fault
GND	Abbreviation for ground connection
GripForce	Setting the gripping force
Offset	Correction value
PositionTolerance	Tolerance range for TeachPosition, BasePosition and WorkPosition The value of the parameter acts in both directions.
StatusWord	Summary of binary states of the product that can be returned as information to the control system.
Teach	Adoption of the ActualPosition as the TeachPosition.
TeachPosition	Taught-in workpiece position
Traversing routine	Defined procedure for movement of the gripper jaws
Travel path	Path on which the gripper jaws travel.
WorkpieceNo	Number of the selected workpiece recipe
WorkPosition	Inner jaw position Depending on the application, this can be the end position or the work position.

Content

- 1 Supporting documents 5
 - 1.1 Notices and graphics in the installation and operating instructions 5
- 2 Safety notices 6
- 3 Proper use 7
- 4 Personnel qualification 7
 - 4.1 Electricians 7
 - 4.2 Specialists 7
 - 4.3 Instructed personnel 7
 - 4.4 Service personnel 7
 - 4.5 Additional qualifications 7
- 5 Product description 8
 - 5.1 Possible applications 8
 - 5.2 Type plate 8
- 6 Functional description 9
 - 6.1 LED status display 10
 - 6.1.1 GEP5000IO/GED5000IO LED display 10
 - 6.1.2 GEP5000IL/GED5000IL LED display 11
 - 6.2 Control 12
 - 6.3 Verified configuration examples 12
 - 6.4 Self-locking mechanism 12
- 7 Technical data 13
- 8 Accessories/scope of delivery 13
- 9 Transportation/storage/preservation 13
- 10 Installation 14
 - 10.1 Installing GEP5000 15
 - 10.2 Installing GED5000 16
 - 10.3 Safe shutoff for products with IO-Link 17
 - 10.4 Installing the energy supply 18
 - 10.5 Installing the power supply for GEP5000IO/GED5000IO 19
 - 10.6 Installing the power supply for GEP5000IL/GED5000IL 19
 - 10.7 Static charge 20
 - 10.8 Heat dissipation 20
 - 10.9 Installing accessories 20
- 11 Commissioning 21
 - 11.1 Commissioning for GEP5000IO/GED5000IO 21
 - 11.1.1 Switching sequence 21
 - 11.1.2 Cold boot 24
 - 11.1.3 Minimum travel path 24
 - 11.2 Movement profiles GEP5000IO/GED5000IO 25
 - 11.2.1 Movement profile WorkPosition direction 25
 - 11.2.2 Movement profile BasePosition direction 26
 - 11.3 Commissioning for GEP5000IL/GED5000IL 27
 - 11.3.1 Process data 27
 - 11.3.2 IODD import 28
 - 11.3.3 Handshake data transfer method 28
 - 11.3.4 Parameter 29
 - 11.3.5 Cold boot 35
 - 11.3.6 Minimum travel path 35
 - 11.4 Movement profiles GEP5000IL/GED5000IL 36

11.4.1	Movement profile WorkPosition direction	36
11.4.2	Movement profile BasePosition direction	37
11.4.3	Easy Startup	37
11.4.4	Quickstart basic parameters	38
11.4.5	Starting the gripping movement.....	39
11.4.6	Recipe examples	40
12	Operation.....	42
12.1	Menu structure for GEP5000IO/GED5000IO	42
12.2	Operate menu	43
12.3	Menu function for GEP5000IO/GED5000IO	44
12.4	Menu settings for GEP5000IO/GED5000IO	45
12.4.1	Menu 2 TeachPosition window width.....	45
12.4.2	Menu 4 TeachPosition offset	45
12.5	Menu functions for GEP5000IL/GED5000IL	46
13	Gripping force charts.....	46
14	Error diagnosis	47
14.1	Error diagnosis for GEP5000IL/GED5000IL	47
14.2	Error diagnosis for GEP5000IO/GED5000IO	49
15	Table with acyclic data (ISDU)	53
16	Maintenance.....	54
17	Decommissioning/disposal	55
18	RoHS declaration.....	56
19	REACH declaration.....	56
20	Declaration of Incorporation	57
21	Declaration of Conformity	58

1 Supporting documents

NOTICE



Read through the installation and operating instructions before installing or working with the product.

The installation and operating instructions contain important notes for your personal safety. They must be read and understood by all persons who work with or handle the product during any phase of the product lifetime.



The documents listed below are available for download on our website www.zimmer-group.com.

- Installation and operating instructions
 - Catalogs, drawings, CAD data, performance data
 - Information on accessories
 - Technical data sheets
 - General Terms and Conditions, including warranty information.
- ⇒ Only those documents currently available on the website are valid.

In these installation and operating instructions, "product" refers to the product designation on the title page!

1.1 Notices and graphics in the installation and operating instructions

DANGER



This notice warns of an imminent danger to the life and health of people. Ignoring these notices can lead to serious injury or even death.

- ▶ You absolutely must comply with the described measures for avoiding these dangers!
- ⇒ The warning symbols are assigned according to the type of danger.

WARNING



This notice warns of a situation that is potentially hazardous to personal health. Ignoring these notices can cause serious injury or damage to health.

- ▶ You absolutely must comply with the described measures for avoiding these dangers!
- ⇒ The warning symbols are assigned according to the type of danger.

CAUTION



This notice warns of a situation that is potentially hazardous to persons. Ignoring these notices can cause minor, reversible injuries.

- ▶ You absolutely must comply with the described measures for avoiding these dangers!
- ⇒ The warning symbols are assigned according to the type of danger.

NOTICE



This notice warns of possible material and environmental damage. Ignoring these notices can result in damage to the product or the environment.

- ▶ You absolutely must comply with the described measures for avoiding these dangers!
- ⇒ The warning symbols are assigned according to the type of danger.

INFORMATION



This category contains useful tips for handling the product efficiently. Failure to observe these tips will not result in damage to the product. This information does not include any information relevant to health or workplace safety.

2 Safety notices

CAUTION



Risk of injury and material damage in case of non-compliance

Installation, commissioning, maintenance and repairs may only be performed by qualified specialists in accordance with these installation and operating instructions.

The product is state-of-the-art.

The following are examples of situations in which the product may cause a hazard:

- The product is not properly installed, used or maintained.
- The product is not used for its designated purpose.
- The locally applicable regulations, laws, directives or guidelines are not observed.
- ▶ The product may only be used in accordance with these installation and operating instructions and the product's technical data. Any changes or additions to the intended use of the product, as well as modifications to the product, such as those in the following examples, require the written permission of the manufacturer:
 - Use of the product under extreme conditions, such as aggressive fluids or abrasive dusts
 - Additional drilled holes or threads
- ⇒ Zimmer GmbH shall accept no liability for any damage caused by improper use. The operator bears sole responsibility.
- ▶ Make sure that the power supply is disconnected before you mount, adjust, modify, maintain or repair the product.
- ▶ Whenever work is carried out on the product, make sure that the product cannot be actuated by mistake.
- ▶ Perform maintenance tasks, renovation work or attachment work outside of the machine's danger zone when possible.
- ▶ Do not reach into the operational range of the product.
- ▶ Always adhere to the required maintenance intervals.
- ▶ When using the product under extreme conditions, adjust the maintenance interval according to the degree of contamination.
- ▶ Check the completeness and tightening torques of all mounting screws.

CAUTION



Notes and handling regulations for electrostatically sensitive components

Electrostatically sensitive components are individual components, integrated circuits or assemblies that can be damaged by electrostatic fields or electrostatic discharge.

- ▶ When handling electrostatic components, make sure that persons, the work area and packaging are all fully grounded.
- ▶ Touch electronic components only in appropriately identified areas with conductive flooring and only if:
 - You are grounded by means of special bracelets.
 - You wear shoes that are suitable and approved for the discharge of electrostatic charges.
- ▶ Do not bring electronic assemblies into contact with plastics and parts of clothing that have plastic content.
- ▶ Store electronic assemblies on conductive underlays only.
- ▶ Do not install electronic assemblies in the vicinity of data back-up devices or monitors (monitor distance > 100 mm).
- ▶ Perform measurements on electronic assemblies only if:
 - The measuring instrument is grounded (e.g. via a ground conductor).
 - The measuring head is momentarily discharged before measuring with a floating measuring instrument.

3 Proper use

NOTICE



The product is only to be used in its original state with its original accessories, with no unauthorized changes and within the stipulated parameter limits and operating conditions.

Any other or secondary use is deemed improper.

- ▶ Operate the product only in compliance with the associated installation and operating instructions.
 - ▶ Operate the product only when it is in a technical condition that corresponds to the guaranteed parameters and operating conditions.
- ⇒ Zimmer GmbH shall accept no liability for any damage caused by improper use. The operator bears sole responsibility.

- The product is designed exclusively for electric operation using a 24 V DC power supply.
- The product must always be mounted on materials that dissipate heat.
- The product is intended for industrial use.
- The product is to be used as intended in enclosed rooms for temporary gripping, handling and holding.
- The product is not suitable for clamping workpieces during a machining process.
- Direct contact with perishable goods/food is not permitted.
- Observance of the technical data and of the installation and operating instructions are part of proper use.

4 Personnel qualification

WARNING



Injuries and material damage due to inadequate qualification

If inadequately qualified personnel perform work on the product, this can cause serious injuries and significant material damage.

- ▶ All work on the product must be performed by qualified personnel.
- ▶ Before working with the product, read the document in its entirety and make sure that you have understood everything.
- ▶ Observe country-specific accident prevention regulations and the general safety notices.

The following qualifications are a prerequisite for performing various work on the product.

4.1 Electricians

Electricians are able to perform work on electrical systems, can recognize and avoid possible dangers and know the relevant standards and provisions due to their technical training, knowledge and experience.

4.2 Specialists

Specialists are able to perform the assigned work, can recognize and avoid possible dangers and know the relevant standards and provisions due to their technical training, knowledge and experience.

4.3 Instructed personnel

Instructed personnel have been trained by the operating company on the tasks and possible dangers of improper behavior.

4.4 Service personnel

Service personnel are able to perform the assigned work and can recognize and avoid possible dangers due to their technical training, knowledge and experience.

4.5 Additional qualifications

Persons who work with the product must be familiar with the valid safety regulations and laws as well as the standards, guidelines and laws listed in this document.

Personnel who work with the product must have facility-issued authorization to commission, program, configure, operate, maintain and also decommission this product.

5 Product description

CAUTION



Reduction of the gripping force can cause personal injury and material damage

When flexible components are gripped, the gripping force of the product is reduced.

Reduced gripping force can lead to personal injury or material damage, because the components that are being gripped can no longer be securely gripped and transported.

NOTICE



Malfunction in case of non-compliance

► Make sure that the setting of the gripping force and the selection of the gripper finger length are correct to prevent incorrect bracing of the gripper jaws.

5.1 Possible applications

Outside gripping

The product can be used for outside gripping.

MoveToWork command

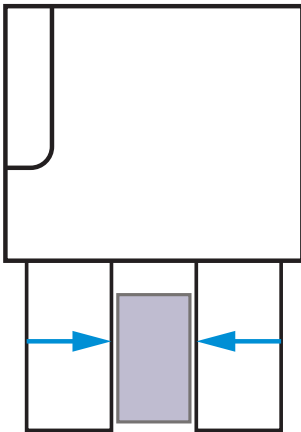

Inside gripping

The product can be used for inside gripping.

MoveToBase command

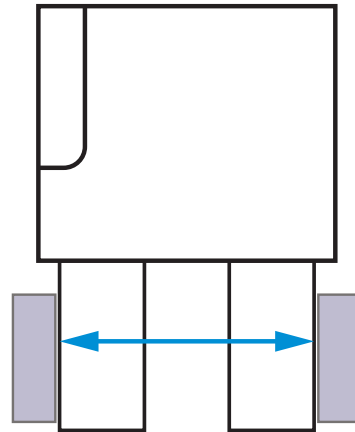

5.2 Type plate

A type plate is attached to the housing of the product.

The article number and confirmation number are shown on the type plate.

① Article number

② Confirmation number

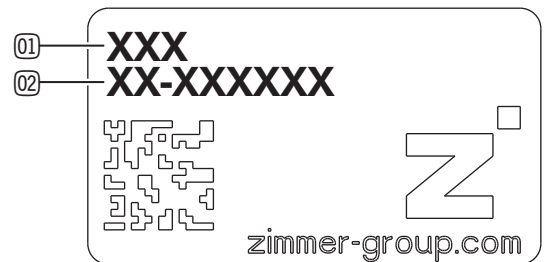

6 Functional description

The gripper jaws of the GEP5000 series are arranged parallel to each other on two opposing guide rails and can be moved relative to each other.

The gripper jaws of the GED5000 series are arranged on three guide rails offset to each other at a 120° angle.

The force of the motor is transmitted by a worm drive. A pinion and a rack generate the movement of the gripper jaws and synchronize these movements.

Despite their small installation space, these products are suited for gripping a wide range of form-fit and frictional fit parts.

The products can be easily integrated into the existing control system.

The gripping force can be adapted optimally to the workpiece conditions via IO-Link.

GEP5000

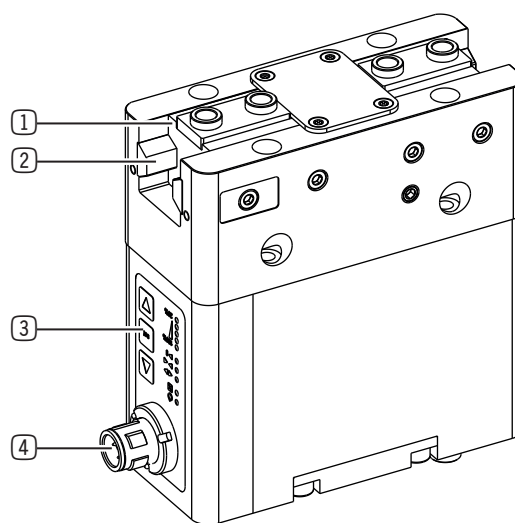

GED5000

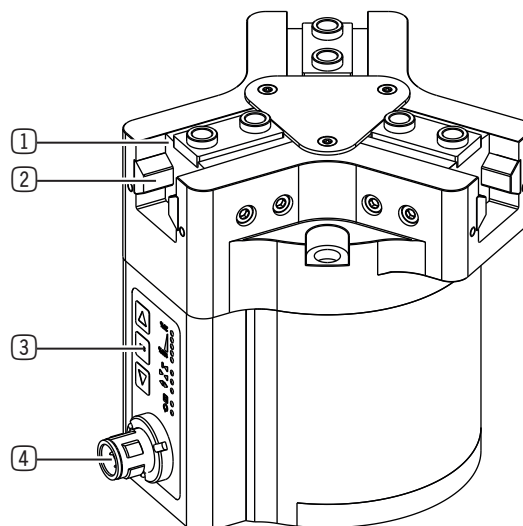

- ① Gripper jaw
- ② Guide rail
- ③ Integrated control module
- ④ Power supply

6.1 LED status display

6.1.1 GEP5000IO/GED5000IO LED display

6.1.1.1 LED display menu

- ① Power supply
- ② Error
- ③ Positions
- ④ Force level/Binary error code
- ⑤ Plus button for parameter values
- ⑥ Set button
- ⑦ Minus button for parameter values

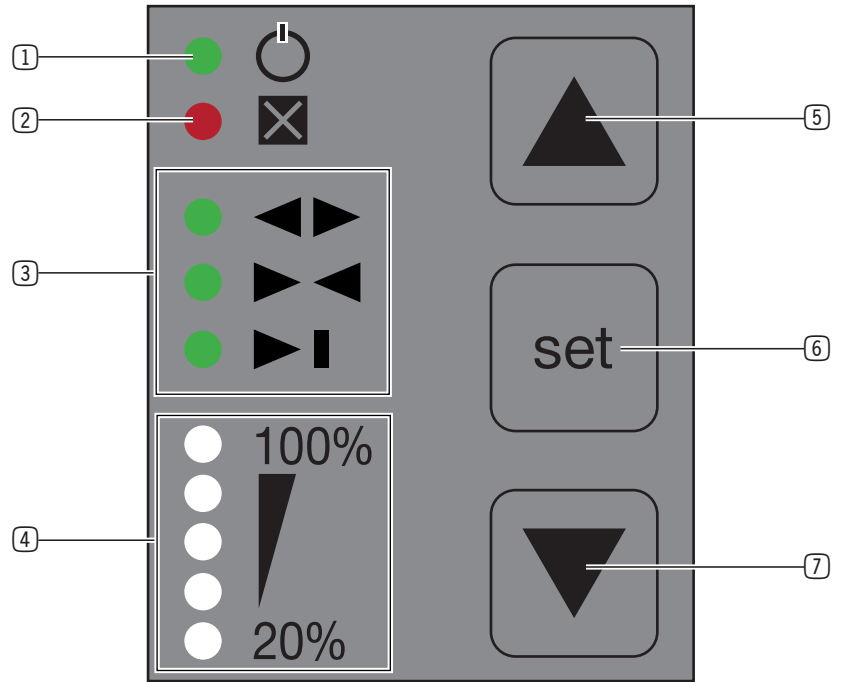

6.1.1.2 LED display of gripper positions

The product is at the BasePosition.
The gripper jaws are open.

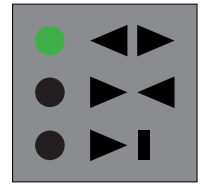

TeachPosition confirmation

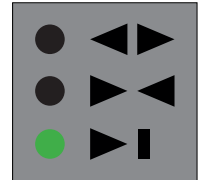

WorkPosition confirmation

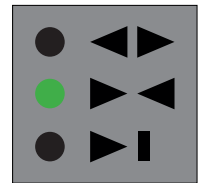

The product is at the TeachPosition.
This simultaneously corresponds to the WorkPosition.

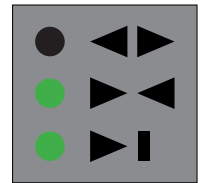

6.1.2 GEP5000IL/GED5000IL LED display

INFORMATION



For products with IO-Link only the LED display is active, the buttons have no function. The configuration of functions and all settings are made via the control system.

- ▶ See the “GEP5000IO/GED5000IO LED display” section for information about the gripper position display.
- ▶ Please contact Customer Service if you have any questions.

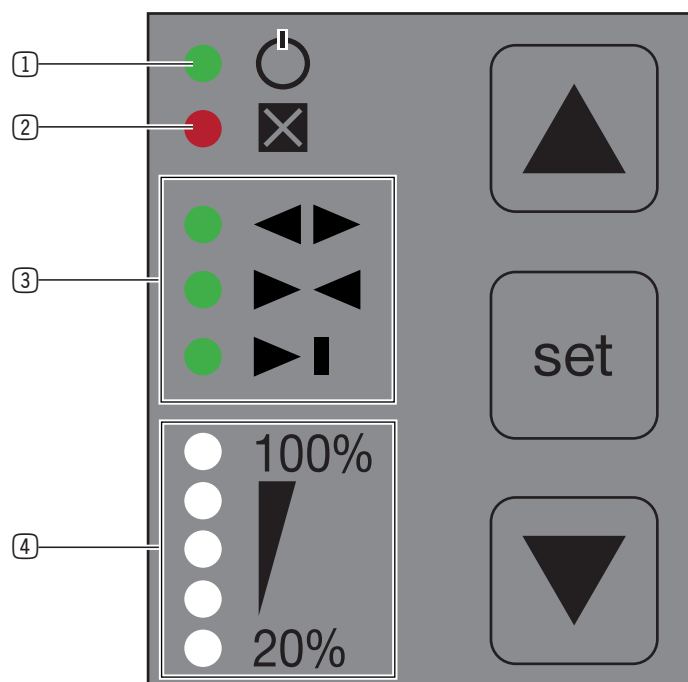

- ① Power supply
- ② Error
- ③ Positions
- ④ Force level

6.2 Control

INFORMATION



- ▶ You can find the information in the technical data sheet on our website.
- ▶ Please contact Customer Service if you have any questions.

6.3 Verified configuration examples

INFORMATION



- ▶ You can find information on our website.
 - GEP5000 series
 - GED5000 series
- ▶ Please contact Customer Service if you have any questions.

6.4 Self-locking mechanism

INFORMATION



The product has a mechanical self-locking mechanism to ensure that the workpiece remains held by the product in the event of power supply loss or failure (e.g. an emergency stop).

7 Technical data

INFORMATION



- ▶ You can find the information in the technical data sheet on our website.
- This data varies within the series, depending on the specific design.
- ▶ Please contact Customer Service if you have any questions.

8 Accessories/scope of delivery

INFORMATION



- If any accessories not sold or authorized by Zimmer GmbH are used, the function of the product cannot be guaranteed. Zimmer GmbH accessories are specifically tailored to the individual products.
- ▶ For optional accessories and those included in the scope of delivery, refer to our website.

9 Transportation/storage/preservation

- ▶ Transport and storage of the product must be done only with the original packaging.
- ▶ If the product has already been installed on the superordinate machine unit, care must be taken during transport to ensure that no unexpected movements can occur.
 - ▶ Before commissioning the product and after transport, check all power and communication connections as well as all mechanical connections.
- ▶ If the product is stored for an extended period, the following points are to be observed:
 - ▶ Keep the storage location as dust-free and dry as possible.
 - ▶ Avoid temperature fluctuations.
 - ▶ Avoid wind/drafts/water condensation formation.
 - ▶ Pack the product and do not expose it to direct sunlight during storage.
- ▶ Clean all components. There must be no soiling left on the components.
- ▶ Visually inspect all components.
- ▶ Remove all foreign substances.
- ▶ Properly remove potential corrosion spots.
- ▶ Close electrical connections using suitable covers.

10 Installation

WARNING



Risk of injury due to uncontrolled movements

Risk of injury in case of unexpected movement of the machine or system into which the product is to be installed.

- ▶ Switch off the energy supply of the machine before any work.
- ▶ Secure the power supply against being switched on unintentionally.
- ▶ Check the machine for any residual energy that may be present.

CAUTION



Risk of injury due to uncontrolled movements

Risk of injury in the event of uncontrolled movement of the product when the power supply is connected.

- ▶ Switch off the power supply to the machine before carrying out any work.
- ▶ Secure the power supply against being switched on unintentionally.
- ▶ Check the machine for any residual energy that may be present.

NOTICE



Installation may only be carried out by qualified personnel in accordance with these installation and operating instructions.

- ▶ Switch off the power supply before any assembly, installation or maintenance work.

INFORMATION



Requirements for the mounting surface:

- Permissible unevenness [mm]: 0.03
- Cleanliness of the mounting surfaces of the product and mounting piece (product grounding)

Further installation information:

- The mounting screws are not included in the scope of delivery.
- Strength class of the mounting screws is at least 8.8 (DIN EN ISO 4762)

- ▶ Install the product on an appropriate mounting surface in accordance with the flatness specifications.
- ▶ Make sure that the mounting piece is sufficiently rigid.
- ▶ Please note the permitted tightening torques of the mounting screws at www.zimmer-group.com/de/td.

10.1 Installing GEP5000

The product can be installed from multiple sides.

- ▶ Insert the centering sleeves into the provided fits on the product.
- ▶ Position the product on the mounting piece using centering sleeves.
- ▶ Mount the product on the mounting piece using the appropriate mounting screws.

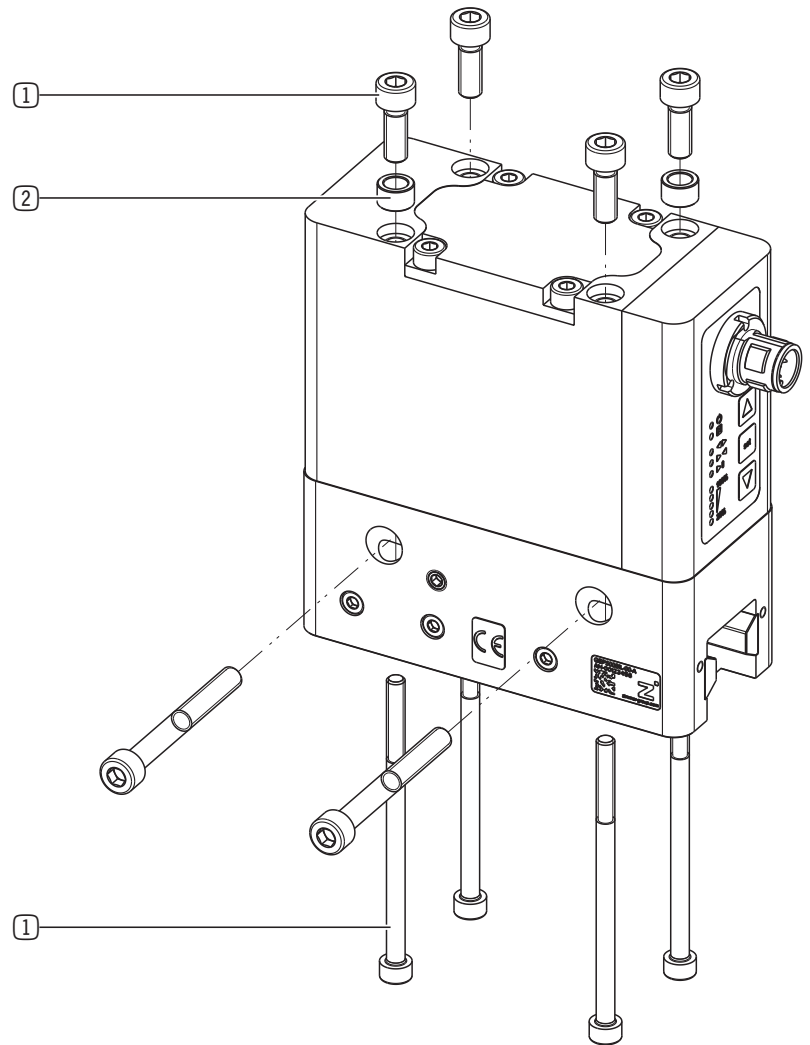

- ① Mounting screw
- ② Centering Disc

10.2 Installing GED5000

The product can be installed from multiple sides.

- ▶ Insert the straight pins into the designated fits on the product.
- ▶ Position the product on the mounting piece with the straight pins.
- ▶ Mount the product on the mounting piece using the appropriate mounting screws.

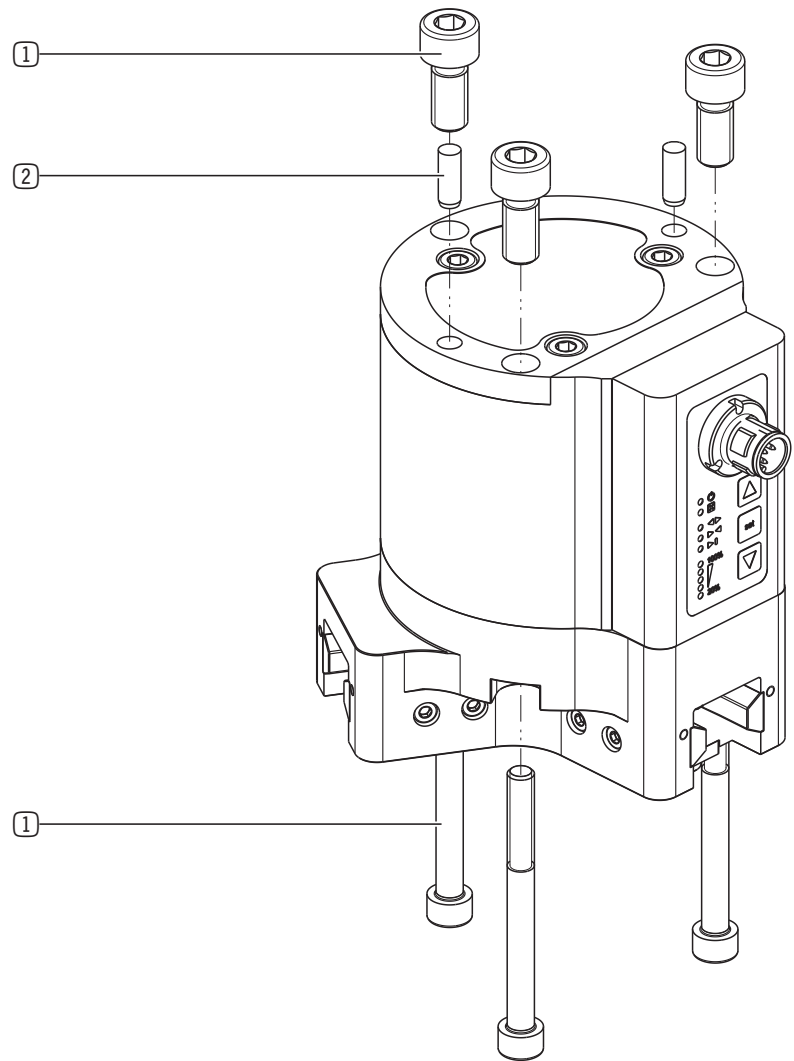

- ① Mounting screw
- ② Straight pins

10.3 Safe shutoff for products with IO-Link

INFORMATION



For safe shutoff for IO-Link products, two contactors are switched in series with one auxiliary contact each. Here, the auxiliary contacts monitor the status of the contactors. If one contactor does not switch, the second contactor ensures safety. The malfunction can still be detected using the contacts.

The following figure shows the example of a circuit through which the IO-Link master cannot conduct the load current of the product.

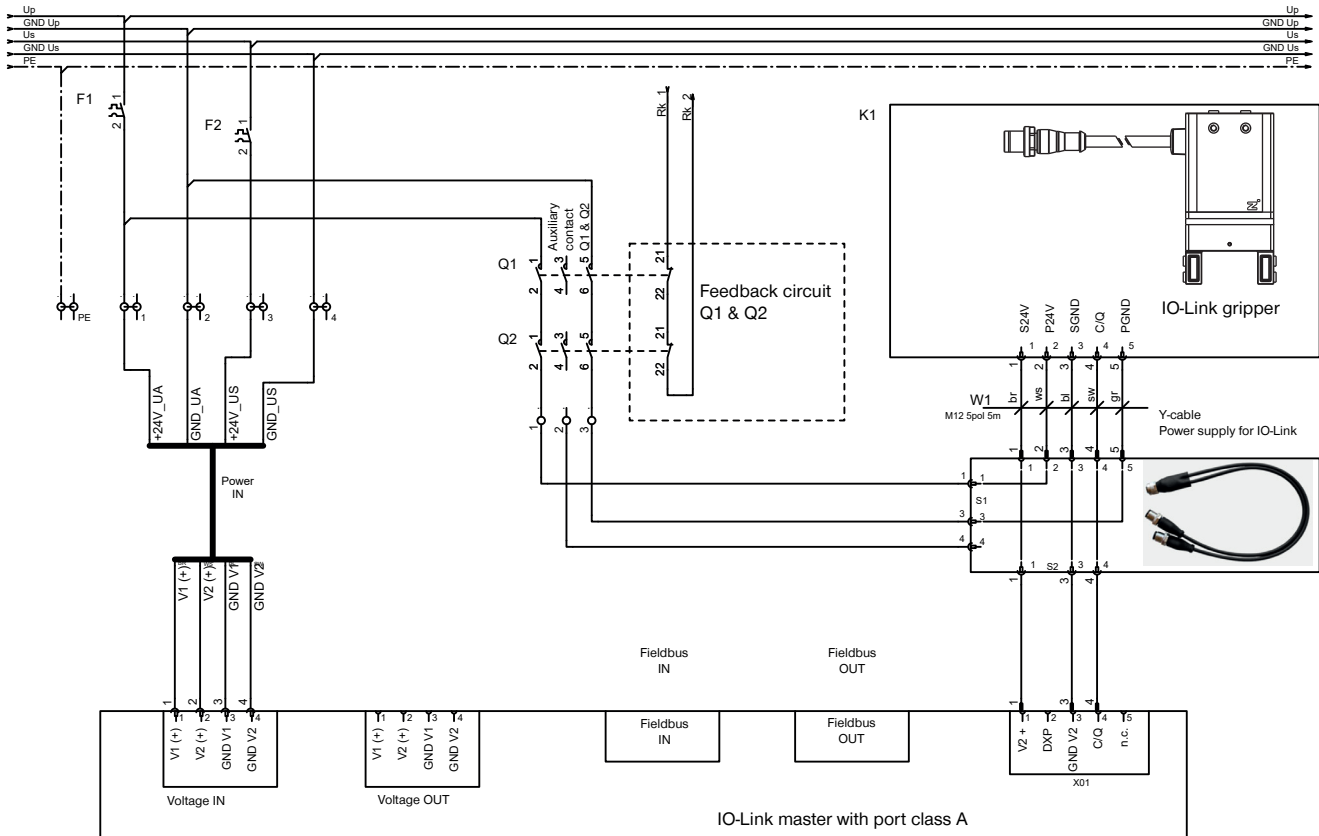

NOTICE



Without an externally fed voltage supply, the motor of the product cannot carry out an active movement and thus cannot carry out a hazardous movement.

There is no galvanic separation between the two voltage supplies (signal and power). There is a low-voltage connection via the ground (GND).

Because of the self-locking mechanism, the product remains in the last approached position, even if no voltage is supplied.

10.4 Installing the energy supply

NOTICE



Destruction of the product

In the event that the polarity of the product is reversed, the IO-Link chip may be destroyed as a result of the duration of current of the C/Q (pin 4) being too long.

- ▶ Connect the product according to its assignment diagram.

NOTICE



Non-compliance may result in material damage.

The cable mounted on the product can be subjected to a torsional angle of +50°.

- ▶ Do not route the cable so that it is strained.
 - ▶ You must meet the minimum bending radius of 10x the outer diameter.
 - ▶ Secure free-hanging cables to prevent excessive motion loads or pinching.
 - ▶ The contacts of the energy supply must be dry, clean and undamaged at all times.
- ⇒ Damage to the contacts can result in malfunction of the product.

- ▶ Connect the power supply cable to the control system of the product.

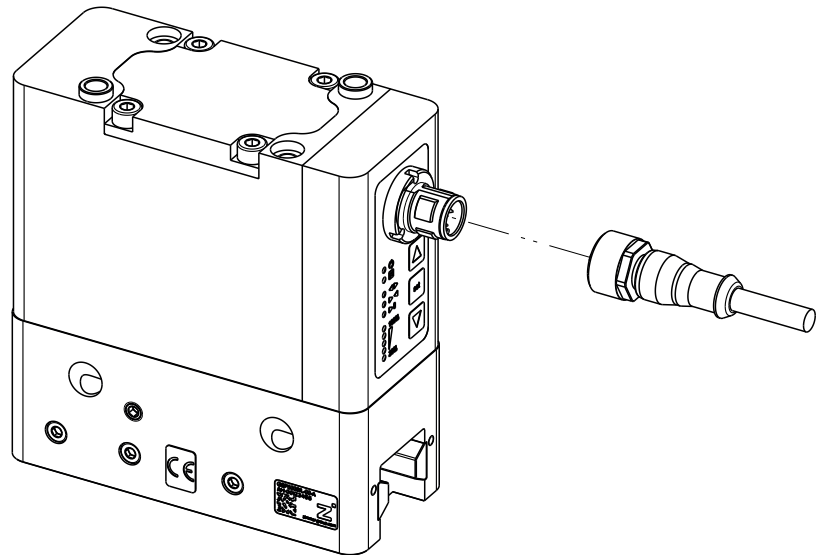

10.5 Installing the power supply for GEP5000IO/GED5000IO

- ▶ Connect the product to the voltage supply.
 - ▶ Ensure the proper voltage supply.
 - A voltage supply between pin 6 and pin 8 is necessary for operation.
- ⇒ A jaw movement is triggered by a voltage level to Pin 1.

pin	Color	Function	Explanation
1	White	DIR	Product control input, open/close
2	Brown	WorkPosition	WorkPosition confirmation
3	Green	Error	Fault confirmation
4	Yellow	TeachPosition	TeachPosition confirmation
5	Gray	BasePosition	BasePosition confirmation
6	Pink	PWR	24 V DC supply voltage
7	Blue	Teach/Adjust	Workpiece programming control input
8	Red	GND	0 V DC supply voltage

M12 8-pin plug

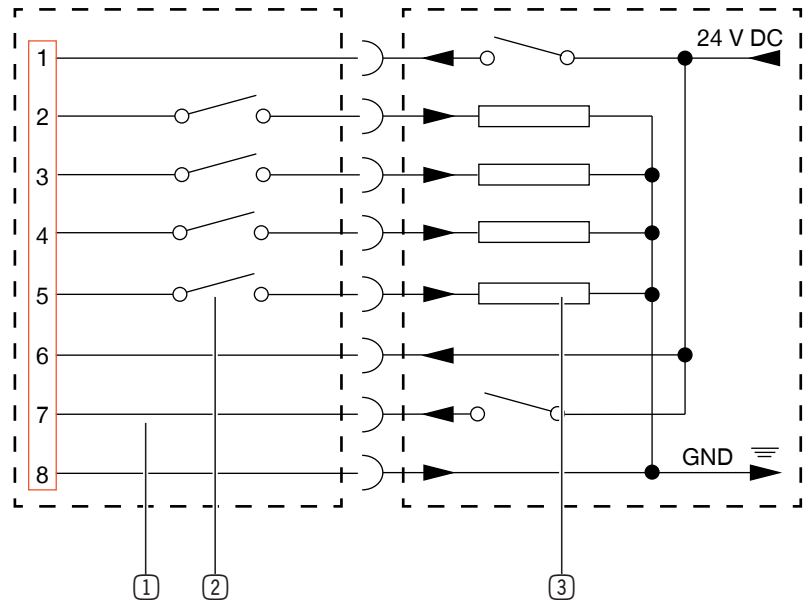

- ① Product
- ② Position sensing at sensors
- ③ External control and programming unit

10.6 Installing the power supply for GEP5000IL/GED5000IL

- ▶ Connect the product to the IO-Link master.
- ▶ Ensure the proper voltage supply.
- ▶ Configure the IO-Link master, see the "Commissioning" section.

pin	Color	Function	Explanation
1	Brown	24 V DC sensor	24 V DC supply voltage for IO-Link communication
2	White	PWR actuator	24 V DC supply voltage for actuator
3	Blue	GND sensor	0 V DC supply voltage for IO-Link communication
4	Black	C/Q	IO-Link communication
5	Gray	GND actuator	0 V DC supply voltage for actuator

M12 5-pin plug

10.7 Static charge

CAUTION



Non-compliance may result in material damage.

Grounding the product is recommended if ESD sensitive parts come into contact with the product.
Grounding is also recommended in applications that require high EMC shielding.

The movement of the gripper jaws creates low voltages as a result of static charging. These charges cannot be dissipated if the product is mounted on an insulating surface and if discharge is also not possible through the workpiece.

10.8 Heat dissipation

In the event of high ambient temperatures, the product must be installed on heat-dissipating materials.

If the product is operated under very high ambient temperatures and with fast clock cycles on an ongoing basis, this might reduce its service life.

INFORMATION



▶ The cycle time must therefore be reduced as the temperature increases.

10.9 Installing accessories

NOTICE



- ▶ Before installing an accessory, make sure it is suitable for use with the selected variant.
- ▶ You can find information on our website.
- ▶ Please contact Customer Service if you have any questions.

11 Commissioning

WARNING



Risk of injury from crushing

Removing the cover of the wedge hook transmission results in a crushing hazard between the gripper jaws. Crushing injuries can result from the gripping process.

- ▶ Make sure that there are no parts of the body in the range of movement of the product!
- ▶ Only permit installation, maintenance and servicing work to be carried out by trained personnel.
- ▶ Do installation, maintenance and servicing work in jog mode only.

CAUTION



Risk of injury from impact

When the gripper jaws are opening, there is a risk of impact in the guide area.

11.1 Commissioning for GEP5000IO/GED5000IO

11.1.1 Switching sequence

CAUTION



Risk of injury due to uncontrolled movements

When the energy supply is switched on again, this can lead to uncontrolled travel movements of the gripper jaws if there is an incorrect signal at the DIR input.

A movement in the desired direction occurs when the corresponding signal is at a high level. The signal must then be stopped at the corresponding level.

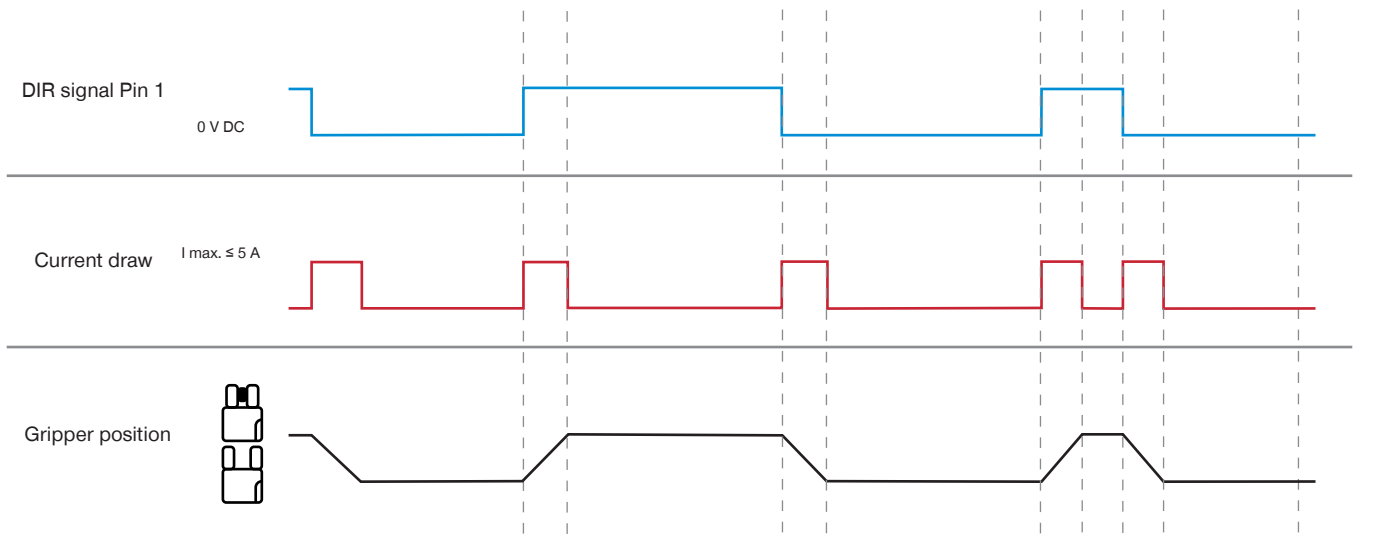

INFORMATION



The switching sequence only applies to the GEP5000IO and GED5000IO products.

NOTICE



- ▶ Please note that the travel movement cannot be canceled by the software.
- ⇒ The travel can be stopped by a workpiece or the mechanical end positions of the product.

INFORMATION



If the energy supply is lost, the workpiece is stopped by the self-locking mechanism of the product.

11.1.1.1 Switching sequence for teaching in the TeachPosition

Using these work steps, you can teach in the product at the TeachPosition.

- ▶ Position the gripper jaws at the desired position.
 - Example: Insert a workpiece to be gripped.
- ▶ Close the product by sending a signal to pin 1.
- ⇒ The following LED displays light up when traveling to the workpiece:
 - Power supply
 - Error
 - Force level

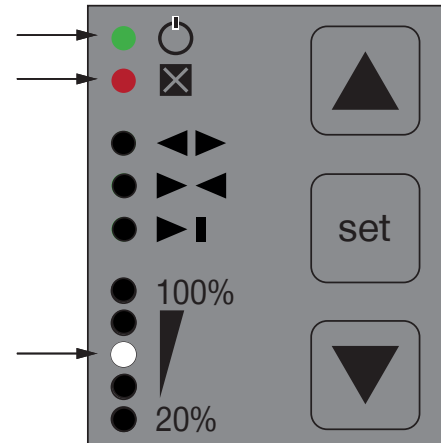

- ▶ Send a signal to the pin 7 control input for 0.5 - 3 seconds.
- ⇒ The TeachPosition lights up green in the position display.

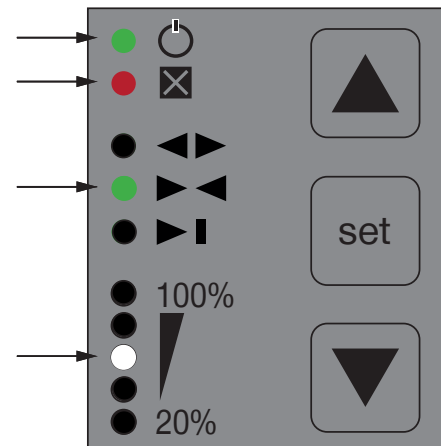

INFORMATION



- ▶ Please note that the error display lights up during initial commissioning.
- ⇒ The error display goes out at the next product movement.

11.1.1.2 Switching sequence for teaching in the end position

This function can be used to teach in the end positions of the product.

- ▶ Make sure that a 0 is set at Pin 1.
- ▶ Make sure that an input signal is switched at Pin 7 for at least 15 seconds.
- ⇒ The product opens and closes several times and stops the process automatically after 5 gripping cycles.
- ⇒ The end positions are confirmed by means of outputs Pin 2 and Pin 5.
- ⇒ The LED display lights up green.

NOTICE



Non-compliance may result in material damage.

- ▶ Make sure that the DIR signal is not interrupted during the travel routing.
- ⇒ Otherwise, the process must be repeated because the end position cannot be correctly determined.

INFORMATION



- ▶ Please note that the product cannot be positioned and always travels to the end position.

INFORMATION



The end positions are preset by the manufacturer.

- ▶ Please note that the end positions must be taught without gripper fingers and the workpiece in order to restore the factory settings.

11.1.2 Cold boot

CAUTION



Risk of injury due to uncontrolled movements

When the energy supply is switched on again, this can lead to uncontrolled travel movements of the gripper jaws if there is an incorrect signal at the DIR input.

INFORMATION



The sensor and actuator power supply are not separate. The product is operational and can perform a motion task via Pin 1 when the energy supply is connected via Pin 6.

Variant	Position	DIR signal Pin 1	Move command
1	BasePosition	0 V DC	No movement The move command towards the WorkPosition direction is activated by applying 24 V to Pin 1.
2	BasePosition	24 V DC	No movement To trigger a move command, 0 V must first be applied to Pin 1 and then 24 V.
3	WorkPosition	0 V DC	The product moves to the BasePosition.
4	WorkPosition	24 V DC	No movement The move command towards the BasePosition direction is activated by applying 0 V to Pin 1.

11.1.3 Minimum travel path

The product requires a certain minimum travel path to move to the desired position.

INFORMATION



The minimum travel path applies to both directions of movement and is independent of the start position. The product moves slightly past the front and rear end position. The value shown on the LED display corresponds to the end position.

Design size	Minimum travel path per gripper jaw [mm]
GEP5006IO/GED5006IO	1.25
GEP5008IO/GED5008IO	1.25
GEP5010IO/GED5010IO	1.25

11.2 Movement profiles GEP5000IO/GED5000IO

11.2.1 Movement profile WorkPosition direction

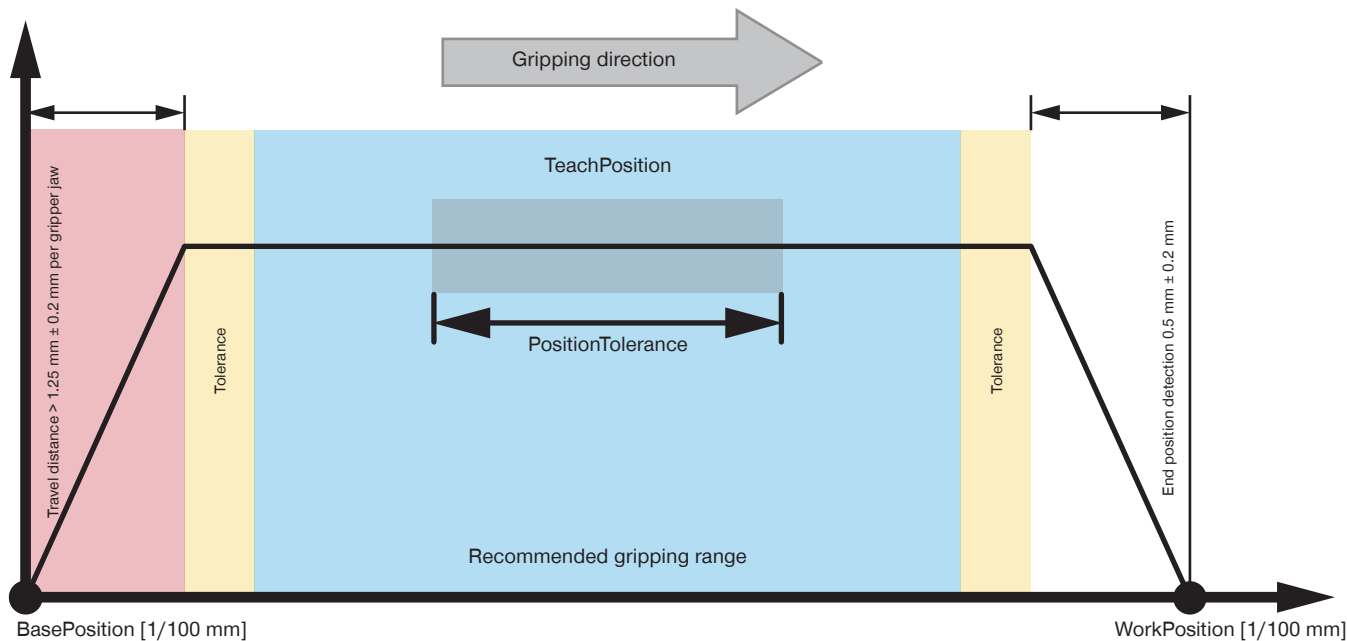

Design size	Calculation	Recommended working stroke [mm]
GEP5006IO/GED5006IO	12 mm - value of end position - value of travel distance	8.6
GEP5008IO/GED5008IO	16 mm - value of end position - value of travel distance	12.6
GEP5010IO/GED5010IO	20 mm - value of end position - value of travel distance	16.6

11.2.2 Movement profile BasePosition direction

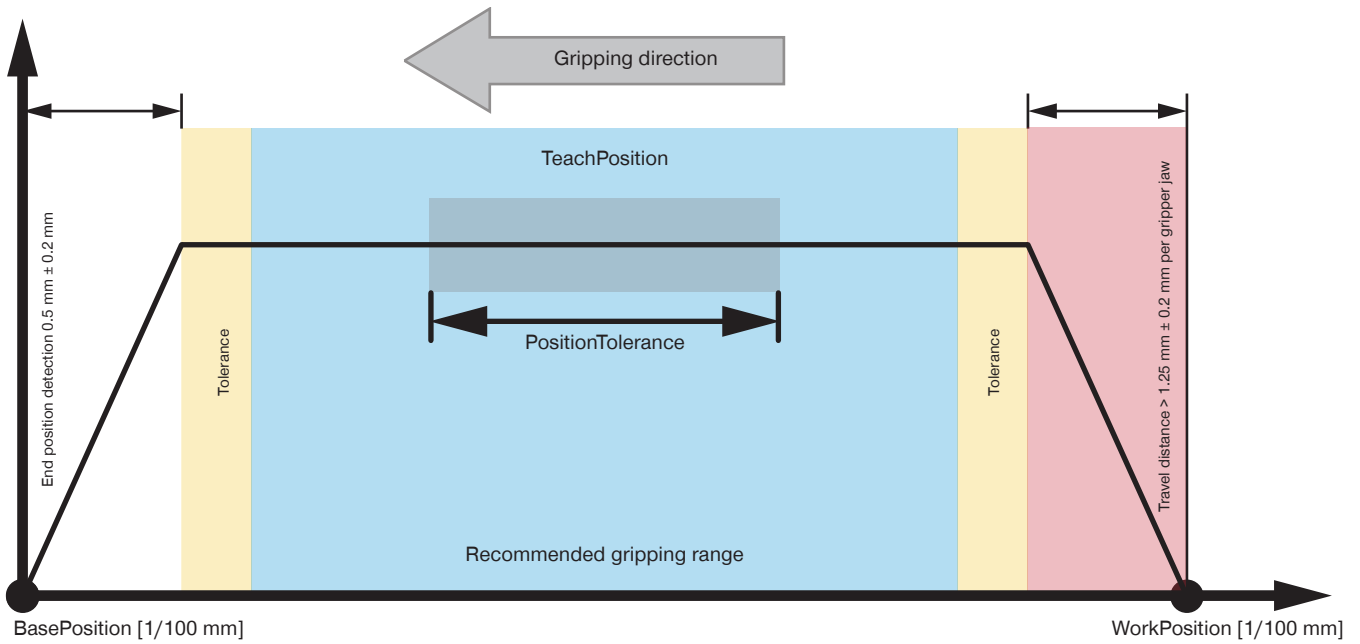

Design size	Calculation	Recommended working stroke [mm]
GEP5006IO/GED5006IO	12 mm - value of end position - value of travel distance	8.6
GEP5008IO/GED5008IO	16 mm - value of end position - value of travel distance	12.6
GEP5010IO/GED5010IO	20 mm - value of end position - value of travel distance	16.6

11.3 Commissioning for GEP5000IL/GED5000IL

11.3.1 Process data

There is an option to control the product only with the process data that is transmitted in each cycle.

Name	Data type
ControlWord	UINT16
DeviceMode	UINT8
WorkpieceNo	UINT8
TeachPosition	UINT16
GripForce	UINT8
PositionTolerance	UINT8

INFORMATION



The terms process data input and output are to be understood from the perspective of the gripper.

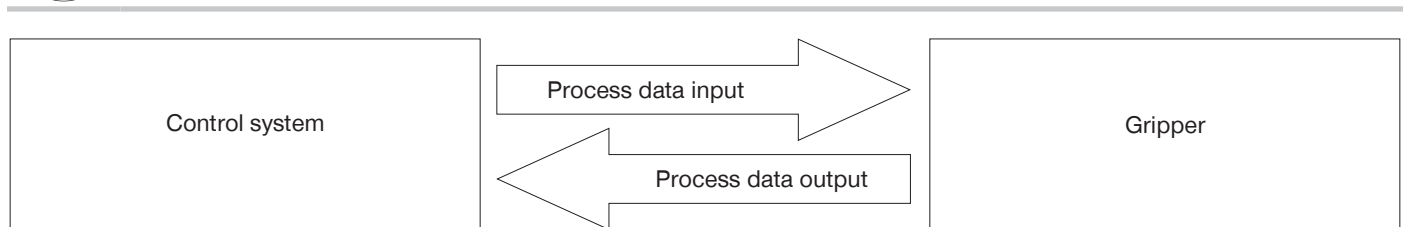

Name	Data type
StatusWord	UINT16
Diagnosis	UINT16
ActualPosition	UINT16

11.3.2 IODD import

- ▶ Import the IODD (device description) into the control system.
 - ▶ Go to our website.
 - ▶ Select the desired product.
 - ▶ Download the corresponding .zip file via the Download IODD link.
 - ⇒ You will need the .zip file for import into the control system.
- ⇒ As soon as the hardware configuration is complete and the IO-Link connection to the product is established, data will be displayed in the process input data.
- ⇒ Some control systems demand a byte swap to bring this process data into a logical sequence.
- ▶ Look at bit 6 (GripperPLCActive) in the StatusWord to determine whether a byte swap is necessary.
 - ▶ Determine whether bit 6 is active in the first or second byte of the StatusWord.
 - ⇒ Bit 6 is active in the first byte: The bytes already have the correct sequence.
 - ▶ Continue with the commissioning.
 - ⇒ Bit 6 is active in the second byte.
 - ▶ Apply a byte swap, refer to the "StatusWord" section.

INFORMATION



The product is controlled via IO-Link by means of the cyclical process data as well as the acyclic service data with a cycle time of 5 ms.

- ▶ It is mandatory to verify the process data!

11.3.3 Handshake data transfer method

The handshake method makes it possible to transfer the process data about the product. All process data described in the following sections must be transferred with the handshake.

- ▶ Send the ControlWord = 0x0001 to the product.
 - ⇒ The data transfer was started.
- ▶ Check the response of the product by using Statusbit 12 = TRUE (data transfer OK).
- ▶ Send the ControlWord = 0x0000 to stop the data transfer.
 - ⇒ The data transmission is complete when the product sends back Statusbit 12 = DataTransferOK = FALSE.

INFORMATION



- ▶ For examples, refer to the "Quickstart Basic Parameters" section.

11.3.4 Parameter

11.3.4.1 ControlWord

NOTICE



In the ControlWord parameter, only one single bit or the value 0 may be set at a time. Only the values listed in the following table are valid.

Parameter	Decimal value	Hexadecimal value
DataTransfer	1	0x0001
WritePDU	2	0x0002
Teach	8	0x0008
Adjust	128	0x0080
MoveToBase	256	0x0100
MoveToWork	512	0x0200
ErrorReset	32768	0x8000

Name	ControlWord
Data format	UINT16
Permission	Write
Transfer	Cyclical
Value range	0 - 65535

	Bit 15	Bit 14	Bit 13	Bit 12	Bit 11	Bit 10	Bit 9	Bit 8
Byte 1	ErrorReset	-	-	-	-	-	MoveToWork	MoveToBase
	Bit 7	Bit 6	Bit 5	Bit 4	Bit 3	Bit 2	Bit 1	Bit 0
Byte 2	Adjust	-	-	-	Teach	-	WritePDU	DataTransfer

Bit 0: DataTransfer

Setting this bit causes the product to acquire the data transmitted in the process data ("WorkpieceNo" = 0) or the data stored in the workpiece data ("WorkpieceNo" = 1 to 32) as the active data set.

Bit 1: WritePDU

Setting this bit tells the product that it should write the current process data to the selected workpiece recipe.

Bit 3: Teach

Setting this bit tells the product to save the current position as the TeachPosition in the selected WorkpieceNo. This only works if there is no "0" that is transmitted in the workpiece number.

Bit 7: Adjust

Setting this bit causes a readjustment of the jaw end positions if no other bit is set in the control word.

Bit 8: MoveToBase

Setting this bit tells the product to move toward the BasePosition.

Bit 9: MoveToWork

Setting this bit tells the product to move toward the WorkPosition.

Bit 15: ErrorReset

This bit can be used to acknowledge all errors that can be reset. Whether an error can be reset is shown in the "Error Diagnosis" section.

11.3.4.2 DeviceMode

The DeviceMode parameter can be used to control the movement of the product and the adaptation to the workpiece. For this purpose, various basic modes and movement profiles are available.

Name	DeviceMode
Data format	UINT8
Permission	Write
Transfer	Cyclical
Value range	1, 2, 3, 60, 70, 100

Input	Mode	Description
1	Universal mode	Inside and outside gripping, both movements at the same speed.
2	Outside gripping	Inward with the desired gripping force and speed, outward at high speed.
3	Inside gripping	Outward with the desired gripping force and speed, inward at high speed.
60	External gripping	Inward with the desired gripping force, outward with the desired speed.
70	Inside gripping	Outward with the desired gripping force, inward with the desired speed.
100	Universal mode	Inside and outside gripping, both movements at the same speed.

INFORMATION



For operation of the product, Zimmer GmbH recommends "DeviceMode" 60, 70 and 100.

11.3.4.3 WorkPieceNo

The workpiece number is used for selecting the previously stored workpiece data, as well as for selecting the "WorkpieceNo" data record in which the current process data is stored.

The "WorkpieceNo" data set enables individual workpieces to be taught in to the product very quickly.

With a value > 0 and data acquisition via a handshake, the corresponding workpiece recipe is loaded in the product.

INFORMATION



For example codes, refer to the "Quickstart Basic Parameters" and "Recipe Examples" sections.

Name	WorkpieceNo
Data format	UINT8
Permission	Write
Transfer	Cyclical
Value range	0 - 32

11.3.4.4 PositionTolerance

Used to configure the position tolerance with a resolution of 0.01 mm.

Thus, the value range of 0 to 255 can be used to set a maximum tolerance of 2.55 mm in both directions.

INFORMATION



Example:

For TeachPosition 1500 (15 mm), PositionTolerance 150 lets you configure a tolerance of 1.5 mm in both directions.

This means that the TeachPosition range starts at 13.5 mm and goes all the way up to 16.5 mm.

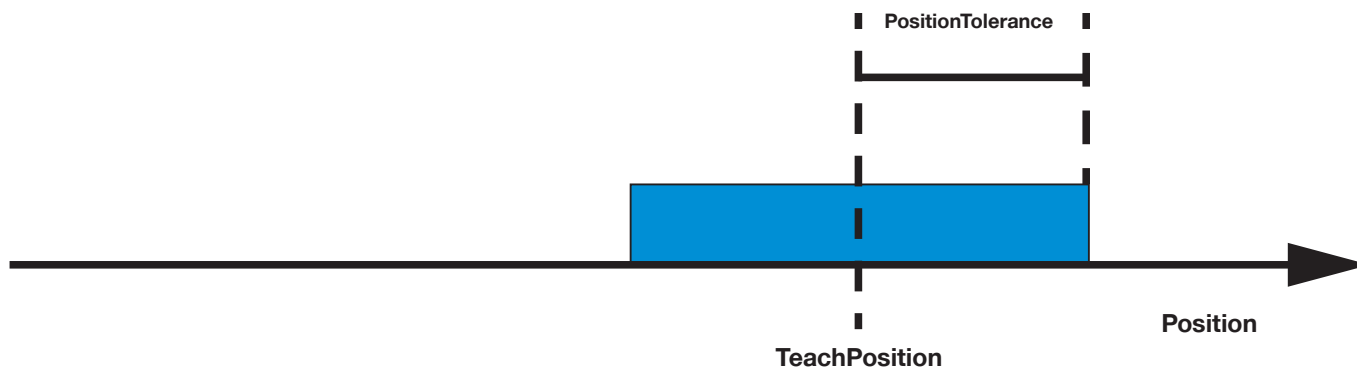

Name	PositionTolerance
Data format	UINT8
Permission	Write
Transfer	Cyclical
Value range	0 to 255

11.3.4.5 GripForce

The product can use various gripping forces and gripping speeds to achieve an optimized flow of the gripping process. Since the product generates gripping force from the gripping speed and the amperage, the gripping force setting also conversely influences the gripping speed and amperage. The gripping force can be adjusted in five stages.

Name	GripForce	
Data format	UINT8	
Permission	Write	
Transfer	Cyclical	
Value range	1	Level 1
	2	Level 2
	3	Level 3
	4	Level 4
	5	Stage 5

INFORMATION



- ▶ For the values for the gripping force, refer to the technical data sheet on our website.
- This data varies within the series, depending on the specific design.
- ▶ Please contact Customer Service if you have any questions.

11.3.4.6 TeachPosition

The TeachPosition notifies the product of the expected position of the workpiece. The tolerance range around the expected position of the workpiece is defined using the PositionTolerance. The StatusWord notifies the control system of whether the desired workpiece has been gripped. The user can monitor this work step with the Teach bit.

With the position measuring system used, it is possible to achieve position accuracy of ± 0.2 mm.

- ▶ Use the following values:

Product	BasePosition	WorkPosition	TeachPosition
GEP5006IL/GED5006IL	0	1200	0 to max. 1200
GEP5008IL/GED5008IL	0	1600	0 to max. 1600
GEP5010IL/GED5010IL	0	2000	0 to max. 2000

Name	TeachPosition
Data format	UINT16
Permission	Write
Transfer	Cyclical
Value range	0 to max. jaw stroke of the product

11.3.4.7 StatusWord

StatusWord structure:

	Bit 15	Bit 14	Bit 13	Bit 12	Bit 11	Bit 10	Bit 9	Bit 8
Byte 1	Error	ControlWord 0x0200	ControlWord 0x0100	DataTransferOK	Undefined- Position	WorkPo- sition	TeachPo- sition	BasePo- sition
	Bit 7	Bit 6	Bit 5	Bit 4	Bit 3	Bit 2	Bit 1	Bit 0
Byte 2	-	Gripper- PLCActive	-	-	-	-	-	-

Bit 6: GripperPLCActive

Active as soon as the product has booted up after the cold boot. This bit can be used to verify a "byte swap."

Bit 8: BasePosition

Active if the product is set to BasePosition.

Bit 9: TeachPosition

Active if the product is set to TeachPosition.

Bit 10: WorkPosition

Active if the product is set to WorkPosition.

Bit 11: UndefinedPosition

Active if the product is not set to TeachPosition, WorkPosition or BasePosition.

Bit 12: DataTransferOK

This bit is used for data transmission using the handshake. Active as soon as the product has taken over the data using the parameter ControlWord = 1 (decimal).

Bit 13: ControlWord 0x0100

This bit is a direction flag. Active if the last motion task was carried out toward BasePosition.

Bit 14: ControlWord 0x0200

This bit is a direction flag. Active if the last motion task was carried out toward WorkPosition.

Bit 15: Error

Active if the product has an active error. The error message can be determined using Diagnosis.

Name	StatusWord
Data format	UINT16
Permission	Read
Transfer	Cyclical
Value range	0 - 65535

11.3.4.8 Diagnosis

The value returned in Diagnosis corresponds to the error code (see "Error Diagnosis" section).

Name	Diagnosis
Data format	UINT16
Permission	Read
Transfer	Cyclical
Value range	0 - 65535

If the product has a fault, the error bit is set in the status word.

- ▶ Acknowledge the error by sending ControlWord 0x8000.

NOTICE



Not all errors can be reset. For some errors, the error message is not reset after acknowledgment. In this case, wait until correct values are sent to the product.
Example: Overheating error

INFORMATION



- ▶ Use StatusWord to verify correct gripping.
- ▶ The TeachPosition tolerance can be adjusted in another process parameter.
- ▶ For sensing the correct position via the ACTUAL position, the tolerances and fluctuations of the value must be observed during programming.

11.3.4.9 ActualPosition

ActualPosition corresponds to the current position of the gripper jaws relative to the full stroke.

The value is specified with a resolution of 0.01 mm.

The values can move between the BasePosition (minimum values) and the WorkPosition (maximum values).

Product	BasePosition	WorkPosition
GEP5006IL/GED5006IL	0	1200
GEP5008IL/GED5008IL	0	1600
GEP5010IL/GED5010IL	0	2000

Name	ActualPosition
Data format	UINT16
Permission	Read
Transfer	Cyclical
Value range	0 to max. jaw stroke of the product

INFORMATION



- ▶ Use the StatusWord to check whether a workpiece has been gripped correctly.
 - The position measurement resolution is 0.01 mm.
 - The position measurement accuracy is 0.2 mm.
- ▶ During commissioning, be aware of fluctuations around the exact value if you use ActualPosition to detect the workpiece.

11.3.5 Cold boot

INFORMATION



If the sensor supply is disconnected, the C/Q signal (IO-Link) must be disconnected as well.

For proper function, Zimmer GmbH recommends that the actuator and sensor voltage be supplied with power separately. The sensor supply must be switched on first.

As soon as the product is communicating with the PLC, the actuator power supply can be switched on. Depending on the application, simultaneous activation of both voltages is also possible.

11.3.6 Minimum travel path

The product requires a certain minimum travel path to move to the desired position.

INFORMATION



The minimum travel path applies to both directions of movement and is independent of the start position. The product moves slightly past the front and rear end position. The value shown on the LED display corresponds to the end position.

Design size	Minimum travel path per gripper jaw [mm]
GEP5006IL/GED5006IL	1.25
GEP5008IL/GED5008IL	1.25
GEP5010IL/GED5010IL	1.25

11.4 Movement profiles GEP5000IL/GED5000IL

11.4.1 Movement profile WorkPosition direction

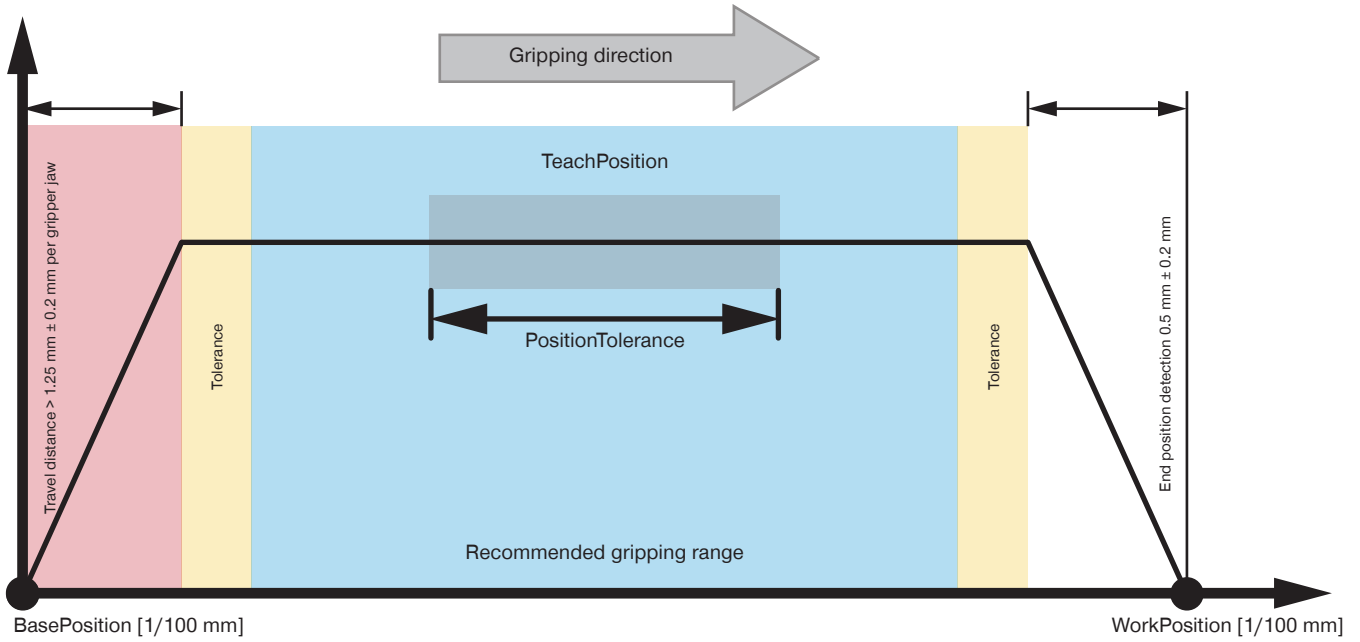

Design size	Calculation	Recommended working stroke [mm]
GEP5006IL/GED5006IL	12 mm - value of end position - value of travel distance	8.6
GEP5008IL/GED5008IL	16 mm - value of end position - value of travel distance	12.6
GEP5010IL/GED5010IL	20 mm - value of end position - value of travel distance	16.6

11.4.2 Movement profile BasePosition direction

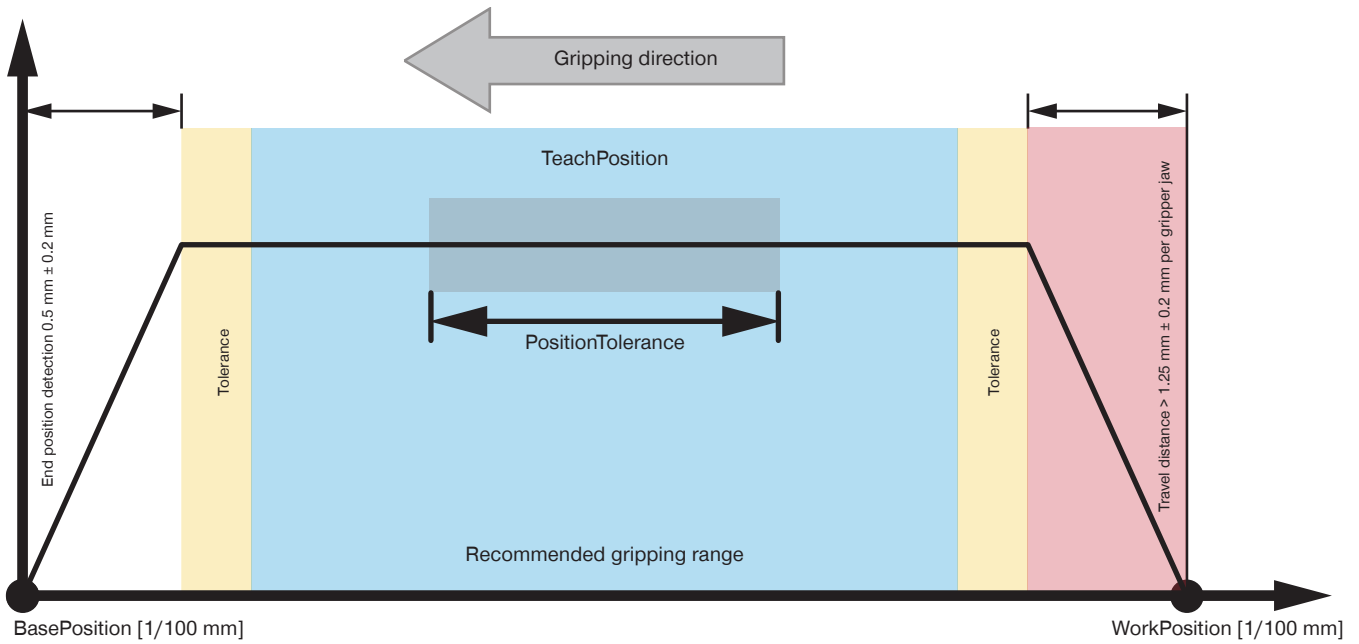

Design size	Calculation	Recommended working stroke [mm]
GEP5006IL/GED5006IL	12 mm - value of end position - value of travel distance	8.6
GEP5008IL/GED5008IL	16 mm - value of end position - value of travel distance	12.6
GEP5010IL/GED5010IL	20 mm - value of end position - value of travel distance	16.6

11.4.3 Easy Startup

Describes the process from switching on the product to the initial movement.

- ▶ Connect the product according to its assignment diagram.
- ⇒ The product reports the process parameters StatusWord, Diagnosis and ActualPosition immediately after the internal controller is booted up.
- ⇒ As soon as the PLCActive bit is registered in the StatusWord, the communication process can start.
- ▶ Transmit the process parameters to move the product.
 - DeviceMode
 - GripForce
 - PositionTolerance
- ▶ Transmit the parameters to the product with a handshake.

INFORMATION



▶ For more information please refer to the „Handshake Data Transfer Method“ section.

11.4.4 Quickstart basic parameters

In the following example, you see the first initialization of the product and the transmission of the process parameters.

```
// Initialization of the product,
// Initial move command
// = EasyStartUp Example

IF bStart = TRUE THEN
    iStep          := 10;
END_IF

CASE iStep OF

10:
    IF StatusBit.6 THEN          // Query for PLCActive bit in the StatusWord
        ControlWord          := 1; // Sends the DataTransfer bit in the ControlWord for initialization
        iStep                 := 20; // Jump to the next step
    END_IF

20:
    IF StatusBit.12 THEN         // Query for DataTransferOK bit in the StatusWord
        ControlWord          := 0; // Reset of the initialization
        iStep                 := 30; // Jump to the next step
    END_IF

30:
    IF NOT StatusWord.12 THEN
        DeviceMode           := 100; // Command to select the universal mode
        GripForce             := 4; // Gripping force setting
        ControlWord           := 1; // Data transfer to the product
        iStep                 := 40; // Jump to the next step
    END_IF

40:
    IF StatusWord.12 THEN       // Query for DataTransferOK bit in the StatusWord
        ControlWord          := 0; // Reset the ControlWord
        iStep                 := 50; // Jump to the next step
    END_IF

50:
    IF NOT StatusWord.12 THEN   // Query for DataTransferOK bit in the StatusWord
        ControlWord          := 512; // Handshake is completed,
        // Product moves to WorkPosition (0x0200 or 512(decimal) = MoveToWork)
        iStep                 := 100;
    END_IF

100:
    ; // Continue with the program

END_CASE
```

11.4.5 Starting the gripping movement

- ▶ Send ControlWord 0x0200 so that the product moves towards the WorkPosition.
- ⇒ The gripper jaws move towards the inside.
- ▶ Send ControlWord 0x0100 so that the product moves towards the BasePosition.
- ⇒ The gripper jaws move towards the outside.
 - The motion task must be pending for as long as it takes until the desired position is reached.
- ⇒ When the product reaches the corresponding position, this is displayed in the StatusWord as follows:
 - The product is at the BasePosition: StatusWord bit 8 = TRUE
 - The product is at the TeachPosition: StatusWord bit 9 = TRUE
 - The product is at the WorkPosition: StatusWord bit 10 = TRUE

11.4.6 Recipe examples

11.4.6.1 Saving the recipe

The following example code shows how process parameters can be stored in the internal workpiece recipe.

```
// Store tool workpiece recipes in Structured Text (ST)

IF bStart = TRUE THEN
    iStep          := 10;
END_IF

CASE iStep OF

10:
    DeviceMode      := 100;    // Assignment of desired process parameters
    WorkpieceNo     := 3;      // Recipe is to be stored as the third workpiece recipe
    PositionTolerance := 50;
    GripForce       := 3;
    TeachPosition   := 500;
    iStep           := 20;    // Jump to the next step

20:
    ControlWord     := 1;      // Begins with the handshake
    iStep           := 30;    // Jump to the next step

30:
    IF StatusWord.12 THEN      // Queries the bit DataTransferOK=TRUE from StatusWord,
                                // Response of the product to transferred data
        ControlWord     := 0;    // Reset the ControlWord
        iStep           := 40;    // Jump to the next step
    END_IF;

40:
    IF NOT StatusWord.12 THEN  // Query for completion of the data transfer,
                                // DataTransferOK = FALSE
        ControlWord     := 2;    // Handshake is completed,
                                // storage starts here via the WritePDU bit in the ControlWord
        iStep           := 50;    // Jump to the next step
    END_IF;

50:
    IF StatusWord.12 THEN      // Queries the DataTransferOK = TRUE bit from StatusWord
        ControlWord     := 0;    // Reset the ControlWord
        iStep           := 60;    // Jump to the next step
    END_IF;

60:
    IF NOT StatusWord.12 THEN  // Query for completion of the data transfer,
                                // DataTransferOK = FALSE
        iStep           := 0;    // Storage is completed
    END_IF;

END_CASE
```

11.4.6.2 Loading a recipe

The following example code shows how process parameters can be loaded to the internal workpiece recipe.

```
// Load workpiece recipes in Structured Text (ST)

IF bLoad = TRUE THEN
    iStep          := 10;
END_IF

CASE iStep OF

10:
    WorkpieceNo    := 3;    // Load third workpiece recipe
    iStep          := 20;    // Jump to the next step

20:
    ControlWord    := 1;    // Begins with the handshake
    iStep          := 30;    // Jump to the next step

30:
    IF StatusWord.12 THEN          // Queries the bit DataTransferOK=TRUE from StatusWord,
                                    // Response of the product to transferred data
        ControlWord    := 0;    // Reset the ControlWord
        iStep          := 40;    // Jump to the next step
    END_IF;

40:
    IF NOT StatusWord.12 THEN      // Query for completion of the data transfer,
                                    // DataTransferOK = FALSE
        iStep          := 0;    //Handshake is completed,
                                    // Parameters from the third recipe have been taken over into the current process parameters.
    END_IF;

END_CASE
```

12 Operation

12.1 Menu structure for GEP5000IO/GED5000IO

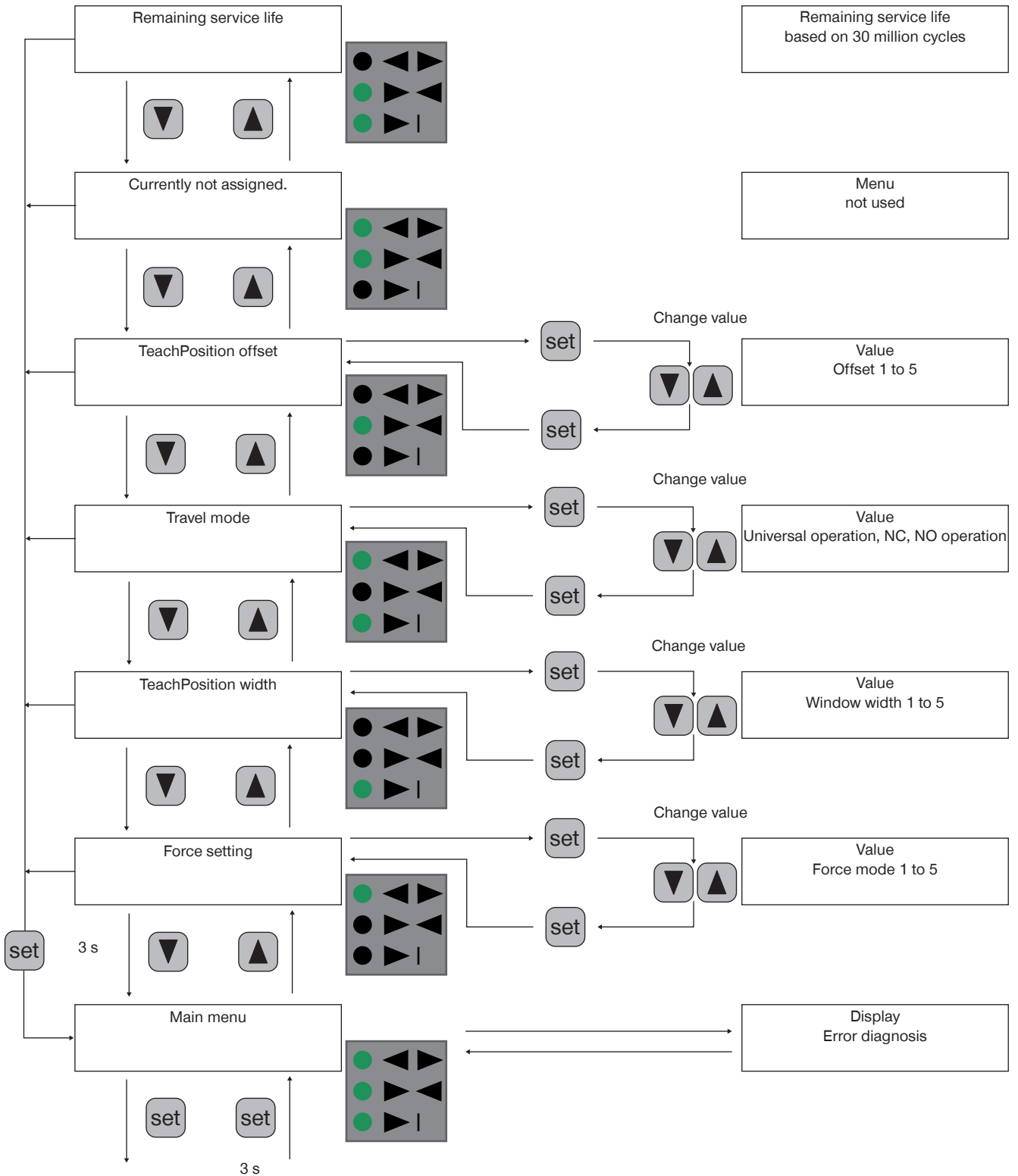

12.2 Operate menu

INFORMATION



The menu function is only available for GEP5000IO and GED5000IO.

⇒ If no input occurs after 3 minutes, the menu window closes without saving.

▶ Please contact Customer Service if you have any questions.

▶ Press the *SET* button for 3 seconds.

⇒ The edit mode is activated when the LED display of the main menu flashes.

▶ Press the *SET* button.

⇒ This activates the parameter selection and the LED display flashes.

▶ Select a value between 1 and 5 using the ▼▲ buttons.

▶ Press the *SET* button.

⇒ The selection has been saved.

⇒ The main menu opens.

⇒ The LED display flashes.

▶ Navigate by pressing the ▼▲ buttons.

▶ Press the *SET* button.

⇒ The main menu is closed.

⇒ The LED display goes out.

CAUTION



Risk of injury and material damage in case of non-compliance

▶ Please note that the product does not travel against a fixed end stop during the fast backwards movement because otherwise the permitted load would be exceeded.

NOTICE



▶ Use force setting 2 or 3 for the defined gripping direction.

⇒ The entire gripping cycle accelerates due to the shorter return time for the gripper jaws. As a result, it is possible to operate the product in a manner that is easy on both the electronics and the mechanical components.

▶ Please contact Customer Service if you have any questions.

12.3 Menu function for GEP5000IO/GED5000IO

<p>Menu 0 Main menu</p>	<p>Error codes are displayed in the main menu.</p>	
<p>Menu 1 Force mode setting</p>	<p>Setting for the gripping force and travel speed in 5 stages.</p> <ul style="list-style-type: none"> • 1 = Low gripping force/low travel speed • 5 = High gripping force/high travel speed <p>Default value: 3</p>	
<p>Menu 2 TeachPosition setting Window width</p>	<p>Setting the TeachPosition window width in 5 stages.</p> <ul style="list-style-type: none"> • 1 = Narrow window width • 5 = Wide window width <p>Default value: 3</p>	
<p>Menu 3 Driving operation setting</p>	<p>Travel mode</p> <ul style="list-style-type: none"> • 1 = Universal operation • 2 = Inside gripping • 3 = Outside gripping <p>Default value: 1</p>	
<p>Menu 4 TeachPosition window offset setting Offset</p>	<p>Offset of the TeachPosition window</p> <ul style="list-style-type: none"> • 1 = Large offset in the direction of the BasePosition • 2 = Small offset in the direction of the BasePosition • 3 = No offset • 4 = Small offset in the direction of the WorkPosition • 5 = Large offset in the direction of the WorkPosition <p>Default value: 3</p>	
<p>Menu 5 Not assigned</p>	<p>-</p>	
<p>Menu 6 Remaining service life display</p>	<p>The LED display for the remaining service life is based on 30 million cycles.</p> <ul style="list-style-type: none"> • 1 = Low remaining service life (< 2 million cycles) • 5 = High remaining service life 	

12.4 Menu settings for GEP5000IO/GED5000IO

12.4.1 Menu 2 TeachPosition window width

Product variants	Area	Window width [mm]
GEP50006/GED50006 GEP50008/GED50008 GEP50010/GED50010	Width 1	± 0.1
	Width 2	± 0.2
	Width 3	± 0.3
	Width 4	± 0.6
	Width 5	± 1.2

12.4.2 Menu 4 TeachPosition offset

Product variants	Teach area position	Offset [mm]
GEP50006/GED50006 GEP50008/GED50008 GEP50010/GED50010	Offset 1	- 0.8
	Offset 2	- 0.4
	Offset 3	0
	Offset 4	0.4
	Offset 5	0.8

INFORMATION



Example:

For TeachPosition 500 (5.00 mm), you can configure a window width of 60 (0.6 mm) in both directions with TeachPosition window width 4 and TeachPosition offset 4. Because of the offset, there is also a shift of 40 (0.4 mm).

This means that workpiece detection starts at 480 (4.80 mm) and goes all the way up to 600 (6.00 mm).

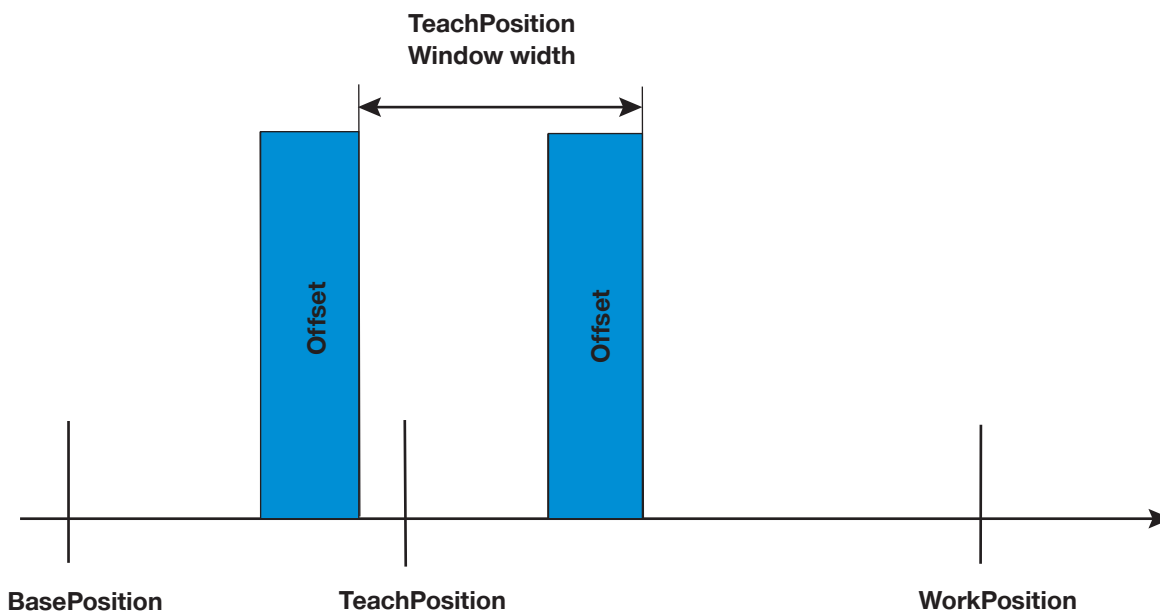

INFORMATION



- ▶ You can find more information about menu operation on our website.
- ▶ Please contact Customer Service if you have any questions.

12.5 Menu functions for GEP5000IL/GED5000IL

INFORMATION



For products with IO-Link, menu operation is performed via the control system.

- ▶ Please contact Customer Service if you have any questions.

13 Gripping force charts

INFORMATION



▶ You can find the information in the technical data sheet on our website.

- ▶ Please contact Customer Service if you have any questions.

14 Error diagnosis

14.1 Error diagnosis for GEP5000IL/GED5000IL

Error code	Error	Possible cause	Measure
0x0000	Device is ready for operation.	-	-
0x0100	Actuator power supply is not present or is too low.	<ul style="list-style-type: none"> Actuator power supply is not connected Actuator power supply is not sufficient Cable break STO input circuit is interrupted. 	<ul style="list-style-type: none"> ▶ Check the actuator power supply. ▶ Switch on the STO input circuit.
0x0101	Temperature above maximum permitted temperature.	<ul style="list-style-type: none"> Ambient temperature is too high. Overload of the products. 	<ul style="list-style-type: none"> ▶ Provide sufficient ventilation/cooling/connection. ▶ Reduce the clock speed/cycle count. ▶ Check that the product moves freely.
0x0102	Max. permitted temperature undershot.	<ul style="list-style-type: none"> Ambient temperature is too low. 	<ul style="list-style-type: none"> ▶ Provide an adequate operating temperature.
0x0300	ControlWord is not plausible.	<ul style="list-style-type: none"> Multiple bits were set in the ControlWord. 	<ul style="list-style-type: none"> ▶ In the ControlWord, check that only one bit is set.
0x0301	Positions are not plausible.	<ul style="list-style-type: none"> Transmitted positions are not plausible. Modified process data were not taken over. 	<ul style="list-style-type: none"> ▶ Check the transmitted process data. ▶ Apply the process data via a handshake.
0x0302	GripForce is not plausible.	<ul style="list-style-type: none"> Transmitted GripForce is not plausible. Modified process data were not taken over. 	<ul style="list-style-type: none"> ▶ Check the transmitted process data. ▶ Apply the process data via a handshake.
0x0303	Required motor speed not reached.	<ul style="list-style-type: none"> Insufficient power supply. Gripper jaws are blocked. Gripper jaws are difficult to move. 	<ul style="list-style-type: none"> ▶ Check the power supply. ▶ Check that the product moves freely.
0x0304	PositionTolerance is not plausible.	<ul style="list-style-type: none"> Transmitted PositionTolerance is not plausible. Modified process data were not taken over. 	<ul style="list-style-type: none"> ▶ Check the transmitted process data. ▶ Apply the process data via a handshake.
0x0305	Position measuring system not referenced.	<ul style="list-style-type: none"> Position measuring system is not referenced. A reference run is being performed. 	<ul style="list-style-type: none"> ▶ Reference the product. ▶ Wait until the reference run is complete.
0x0306	DeviceMode is not plausible.	<ul style="list-style-type: none"> Transmitted DeviceMode is not plausible. Modified process data were not taken over. 	<ul style="list-style-type: none"> ▶ Check the transmitted process data. ▶ Apply the process data via a handshake.
0x0308	WorkpieceNo cannot be selected.	<ul style="list-style-type: none"> Transmitted workpiece number is outside the permitted range. Modified process data were not taken over. 	<ul style="list-style-type: none"> ▶ Check the transmitted process data. ▶ Apply the process data via a handshake.

Error code	Error	Possible cause	Measure
0x0309	TeachPosition was changed.	<ul style="list-style-type: none"> Modified process data were not taken over. 	<ul style="list-style-type: none"> ▶ Apply the process data via a handshake.
0x030D	GripForce was changed.	<ul style="list-style-type: none"> Modified process data were not taken over. 	<ul style="list-style-type: none"> ▶ Apply the process data via a handshake.
0x030F	TeachTolerance was changed.	<ul style="list-style-type: none"> Modified process data were not taken over. 	<ul style="list-style-type: none"> ▶ Apply the process data via a handshake.
0x0310	DeviceMode was changed.	<ul style="list-style-type: none"> Modified process data were not taken over. 	<ul style="list-style-type: none"> ▶ Apply the process data via a handshake.
0x0311	WorkpieceNo was changed.	<ul style="list-style-type: none"> Modified process data were not taken over. 	<ul style="list-style-type: none"> ▶ Apply the process data via a handshake.
0x0312	Initial state after gripper restart	<ul style="list-style-type: none"> Modified process data were not taken over. 	<ul style="list-style-type: none"> ▶ Apply the process data via a handshake.
0x0400	Difficulty of movement	<ul style="list-style-type: none"> Insufficient power supply. Incorrect DeviceMode (NO/NC) selection. The free travel of the gripper (NO/NC) is blocked. Gripper jaws are blocked. Gripper jaws are difficult to move. Travel distance of the gripper jaw is too small. 	<ul style="list-style-type: none"> ▶ Check the power supply. ▶ Check the selected DeviceMode. ▶ Check that the product moves freely. ▶ Check the travel distance.
0x0401	Current limit exceeded.	<ul style="list-style-type: none"> Gripper jaws are blocked. Gripper jaws are tensioned incorrectly. 	<ul style="list-style-type: none"> ▶ Check that the product moves freely.
0x0403	Temperature sensor error	<ul style="list-style-type: none"> Fault of the integrated temperature sensor 	<ul style="list-style-type: none"> ▶ Please contact Customer Service.
0x0404	Position sensor error	<ul style="list-style-type: none"> Fault of the integrated position sensor 	<ul style="list-style-type: none"> ▶ Please contact Customer Service.
0x0405	Travel time/runtime exceeded	<ul style="list-style-type: none"> Gripper jaws are blocked. Gripper jaws are tensioned incorrectly. 	<ul style="list-style-type: none"> ▶ Check that the product moves freely.
0x0406	System error	<ul style="list-style-type: none"> Internal system error 	<ul style="list-style-type: none"> ▶ Please contact Customer Service.

14.2 Error diagnosis for GEP5000IO/GED5000IO

INFORMATION



- ▶ Acknowledge the resetting of errors.
- ⇒ Errors remain active until a switchover of the DIR signal or a zero crossing of the voltage supply.

Error code	Error	Possible cause	Measure
	Device is ready for operation.	-	-
	The motor has excess current in multiple consecutively following cycles.	<ul style="list-style-type: none"> • Difficulty of movement • Travel path is blocked. • Object being gripped or gripper fingers are elastic. 	<ul style="list-style-type: none"> ▶ Check that the product moves freely. ▶ Check the object being gripped and the gripper fingers.
	The motor has excess current.	The product is blocked.	<ul style="list-style-type: none"> ▶ Make sure that the product moves freely. ▶ Please contact Zimmer Customer Service.
	The motor has excess current in idle mode.	<ul style="list-style-type: none"> • Internal error 	<ul style="list-style-type: none"> ▶ Please contact Customer Service.
	Max. permitted temperature undershot.	<ul style="list-style-type: none"> • Ambient temperature is too high. • Overload of the products. 	<ul style="list-style-type: none"> ▶ Provide sufficient ventilation/cooling/connection. ▶ Check that the product moves freely.

Error code	Error	Possible cause	Measure
	<ul style="list-style-type: none"> Product is in reference run. 	<ul style="list-style-type: none"> Internal error 	<ul style="list-style-type: none"> Please contact Customer Service.
	<p>The product does not have any reference position.</p>	<ul style="list-style-type: none"> No reference position A reference run must be performed. 	<ul style="list-style-type: none"> Please contact Customer Service.
	<p>The product is in the end position of the setting run.</p>	<ul style="list-style-type: none"> Setting run was started. 	<ul style="list-style-type: none"> The positions cannot be evaluated during the setting run. Wait until the end of the setting run.
	<p>UndefinedPosition</p>	<p>The product does not reach the end position (BasePosition, WorkPosition, TeachPosition).</p>	<ul style="list-style-type: none"> Check the object being gripped. Check the gripper fingers.
	<p>The product does not achieve the target speed when moving.</p>	<ul style="list-style-type: none"> The guide moves with difficulty. 	<ul style="list-style-type: none"> Please contact Customer Service.

Error code	Error	Possible cause	Measure
	Position sensor error	Internal error	▶ Please contact Customer Service.
	Motor temperature sensor	Internal error	▶ Please contact Customer Service.
	System error/internal error	Internal error	▶ Please contact Customer Service.
	DIR signal = 0 The product does not reach the BasePosition or TeachPosition.	<ul style="list-style-type: none"> • Gripper jaws are blocked. • Gripper jaws are difficult to move. 	<ul style="list-style-type: none"> ▶ Make sure that the product moves freely. ▶ Please contact Zimmer Customer Service.
	DIR signal = 1 The product does not reach the WorkPosition or TeachPosition.	<ul style="list-style-type: none"> • The product moves with difficulty. • The travel path of the product is impeded. 	<ul style="list-style-type: none"> ▶ Make sure that the product moves freely. ▶ Please contact Zimmer Customer Service.

Error code	Error	Possible cause	Measure
	The product is blocked.	<ul style="list-style-type: none"> The product moves with difficulty. The travel path of the product is impeded. 	<ul style="list-style-type: none"> ▶ Make sure that the product moves freely. ▶ Please contact Zimmer Customer Service.
	The product has exceeded the maximum travel time.	<ul style="list-style-type: none"> The product moves with difficulty. The travel path of the product is impeded. 	<ul style="list-style-type: none"> ▶ Make sure that the product moves freely. ▶ Please contact Zimmer Customer Service.
	The product does not achieve the target speed when moving.	<ul style="list-style-type: none"> The product moves with difficulty. 	<ul style="list-style-type: none"> ▶ Please contact Customer Service.
	The product is in NC or NO mode and is blocked from free travel.	<ul style="list-style-type: none"> The product moves with difficulty. The product returns to a fixed end stop. 	<ul style="list-style-type: none"> ▶ Change the travel mode. ▶ Please contact Zimmer Customer Service.

15 Table with acyclic data (ISDU)

INFORMATION



IO-Link distinguishes between cyclical process data (PDU) and acyclic data (ISDU).

Access to acyclic data is not arranged very conveniently for all control system and IO-Link master combinations. For this reason, the product can be used without acyclic data. This makes it as easy as possible to control the product.

► Please contact Customer Service if you have any questions.

INFORMATION



► Note that the acyclic data with the following parameters correspond to the reflection of the process data:

- StatusWord, Diagnosis, ControlWord, ActualPosition, TeachPosition, WorkpieceNo, DeviceMode, PositionTolerance, Gripforce

Index	Name	Data format	Access rights	Values	Description
0x0040 (64)	StatusWord	UINT16	Read	0 - 65535	Parameter to read out the StatusWord.
0x0041 (65)	Diagnosis	UINT16	Read	0 - 65535	Read out of the diagnostic code.
0x0042 (66)	Cycle counter	UINT32	Read	0 to 4294967295	Read out of the total number of cycles.
0x0043 (67)	Temperature	UINT16	Read	0 to 100 °C	Read out the current temperature.
0x0044 (68)	ControlWord	UINT16	Read	0 - 65535	Read out of the ControlWord.
0x0045 (69)	Error code	STRING	Read	1 to 32	Read out of the current error state.
0x0046 (70)	Error counter	UINT32	Read	0 to 4294967295	Read out of the number of errors since the restart.
0x0064 (64)	Firmware application	STRING	Read	1 to 64	Current firmware of the application controller
0x0100 (256)	ActualPosition	UINT16	Read	0 to max. jaw stroke of the product	Read out of the current position of the gripper jaws relative to the full stroke.
0x0101 (257)	TeachPosition	UINT16	Read	0 to max. jaw stroke of the product	Read out of the current transmitted TeachPosition.
0x0102 (258)	WorkpieceNo	UINT8	Read	0 - 32	Read out of the transmitted workpiece number.
0x0103 (259)	DeviceMode	UINT8	Read	1 to 95	Read out of the transmitted travel mode.
0x0104 (260)	PositionTolerance	UINT8	Read	0 to 255	Read out of the transmitted tolerance of the TeachPosition.
0x0105 (261)	GripForce	UINT8	Read	1 to 130 %	Read out of the transmitted gripping force.

16 Maintenance

WARNING



Risk of injury from crushing

Removing the cover of the wedge hook transmission results in a crushing hazard between the gripper jaws. Crushing injuries can result from the gripping process.

- ▶ Make sure that there are no parts of the body in the range of movement of the product!
- ▶ Only permit installation, maintenance and servicing work to be carried out by trained personnel.
- ▶ Do installation, maintenance and servicing work in jog mode only.

CAUTION



Risk of injury from impact

When the gripper jaws are opening, there is a risk of impact in the guide area.

CAUTION



Contact with the greases poses a health hazard

The guide system and the piston chamber are lubricated with greases during installation.

Contact with the greases used poses a health hazard.

- ▶ Wear suitable protective equipment.
- ▶ Only permit installation, maintenance and servicing work to be carried out by trained personnel.

NOTICE



Material damage resulting from blowing out with compressed air

Blowing out the product with compressed air can cause malfunctions and pose a risk of accidents.

- ▶ Never purge the product with compressed air.

NOTICE



Material damage caused by unsuitable cleaning materials

Liquid and solvent-based cleaning agents can cause malfunctions and pose a risk of accidents.

- ▶ Do not clean the product with any cleaning agents that are liquid or contain solvents.

NOTICE



Material damage due to leaking lubricant

Excessive lubrication can cause moving machine parts to leak lubricant. This can cause soiling of the machine, the workpiece and the environment.

- ▶ Only use approved or recommended lubricants.
- ▶ Observe the manufacturer information for use of specific lubricants.
- ▶ Adhere to the lubrication interval.
- ▶ Avoid excessive lubrication.
- ▶ Remove leaking lubricant immediately and thoroughly.
- ▶ Replace damaged seals.

Maintenance-free operation of the product is guaranteed for up to **30 million cycles**.

- ▶ Note that the product could become damaged under the following circumstances:
 - Dirty environment
 - Improper use and use that does not comply with the performance data
 - Permissible temperature range not observed
 - ▶ Even though the product is maintenance-free as mentioned above, perform a regular visual inspection to check for any damage or contamination.
 - ▶ Have maintenance work that requires disassembly of the product performed by customer service if possible.
- ⇒ Dismantling and reassembling the product without authorization may result in complications, as special installation equipment is required in some cases. Zimmer GmbH accepts no liability for any resulting malfunctions or damage.

17 Decommissioning/disposal

INFORMATION



When the product reaches the end of its operational phase, it can be completely disassembled and disposed of.

- ▶ Disconnect the product completely from the power supply.
- ▶ Dispose of the components properly according to the material groups.
- ▶ Comply with the locally applicable environmental and disposal regulations.

18 RoHS declaration

in terms of the EU Regulation 2011/65/EU

Name and address of the manufacturer:

Zimmer GmbH

📍 Im Salmenkopf
77866 Rheinau, Germany
☎ +49 7844 9138 0
✉ info@zimmer-group.com
🌐 www.zimmer-group.com

We hereby declare that the incomplete machine described below

Product designation: 2-jaw parallel gripper/3-jaw concentric gripper, electric

Type designation: GEP5000, GED5000

conforms to the requirements of the directive in its design and the version we put on the market.

Michael Hoch

Authorized representative for the
compilation of relevant technical
documents

Rheinau, Germany, 2020-11-15

(Place and date of issuance)



Martin Zimmer
(Legally binding signature)
Managing Partner

19 REACH declaration

In terms of the EC Regulation 1907/2006

Name and address of the manufacturer:

Zimmer GmbH

📍 Im Salmenkopf
77866 Rheinau, Germany
☎ +49 7844 9138 0
✉ info@zimmer-group.com
🌐 www.zimmer-group.com

REACH stands for **R**egistration, **E**valuation, **A**uthorisation and **R**estriction of **C**hemicals.

A full declaration of REACH can be obtained from the manufacturer due to the duty to notify in accordance with Art. 33 of the REACH regulation ("Duty to communicate information on substances in articles").

Michael Hoch

Authorized representative for the
compilation of relevant technical
documents

Rheinau, Germany, 2020-11-15

(Place and date of issuance)



Martin Zimmer
(Legally binding signature)
Managing Partner

20 Declaration of Incorporation

In terms of the EU Machinery Directive 2006/42/EC (Annex II 1 B)

Name and address of the manufacturer:

Zimmer GmbH

📍 Im Salmenkopf
77866 Rheinau, Germany
☎ +49 7844 9138 0
✉ info@zimmer-group.com
🌐 www.zimmer-group.com

We hereby declare that the incomplete machine described below

Product designation: 2-jaw parallel gripper/3-jaw concentric gripper, electric
Type designation: GEP5000, GED5000

conform to the requirements of the Machinery Directive, 2006/42/EC, Article 2g, Annex VII.b – Annex II.b, in its design and the version we put on the market.

Basic health and safety requirements:

No. 1.1.2, No. 1.1.3, No. 1.1.5, No. 1.3.2, No. 1.3.4, No. 1.3.7, No. 1.3.9, No. 1.5.1, No. 1.5.2, No. 1.5.4, No. 1.5.13, No. 1.6.4, No. 1.7.1, No. 1.7.4

A full list of applied standards can be obtained from the manufacturer.

We also declare that the specific technical documents were produced in accordance with Annex VII Part B of this Directive. We undertake to provide the market supervisory bodies with electronic versions of special documents for the incomplete machine through our documentation department, should they have reason to request them.

The incomplete machine may only be commissioned if it has been ascertained, if applicable, that the machine or system in which the incomplete machine is to be installed satisfies the requirements of Directive 2006/42/EC on Machinery and an EC Declaration of Conformity has been drawn up in accordance with Annex II 1 A.

Kurt Ross
Authorized representative for the compilation of relevant technical documents

Rheinau, Germany, 2021-05-01
(Place and date of issuance)



Martin Zimmer
(Legally binding signature)
Managing Partner

21 Declaration of Conformity

As defined by the EC Directive 2014/30/EU on electromagnetic compatibility

Name and address of the manufacturer:

Zimmer GmbH

📍 Im Salmenkopf
77866 Rheinau, Germany
☎ +49 7844 9138 0
✉ info@zimmer-group.com
🌐 www.zimmer-group.com

We hereby declare that the products described below

Product designation: 2-jaw parallel gripper/3-jaw concentric gripper, electric

Type designation: GEP5000, GED5000

conform to the requirements of the Electromagnetic Compatibility Directive 2014/30/EU in its design and the version we put on the market.

The following harmonized standards have been used:

DIN EN ISO 12100	Safety of machinery - General principles for design - Risk assessment and risk reduction
DIN EN 61000-6-3	EMC Generic standard, Emission standard for residential, commercial and light-industrial
DIN EN 61000-6-2	EMC Generic standard, Emission standard for industrial environments
DIN EN 61000-6-4	EMC Generic standard, Immunity for industrial environments

A full list of applied standards can be obtained from the manufacturer.

Kurt Ross

Authorized representative for the compilation of relevant technical documents

Rheinau, Germany, 2021-05-01

(Place and date of issuance)

Martin Zimmer
(Legally binding signature)
Managing Partner