

INSTALLATION AND OPERATING INSTRUCTIONS

2-jaw parallel gripper, electric

HRC-03

DDOC00268

THE KNOW-HOW FACTORY

Glossary

| Term | Explanation |
|--------------------------|---|
| ActualPosition | Value of the current position of the product [1/100 mm] |
| Adjust | Starts the travel routing stored in the product to teach the BasePosition and WorkPosition. |
| BasePosition | Outer jaw position Depending on the application, this can be the base position or the work position. |
| ControlWord | Activation of the product Only one bit is permitted to be active in ControlWord. The value "0" is also permitted. |
| DeviceMode | Used to select gripping profiles as well as the additional help modes in the product. |
| Diagnosis | If an error occurs, outputs a diagnostic code that can be compared with the error list. |
| DIR | Direction/24 V DC cable connection Depending on the product, this signal is used to move the product. |
| Error | Fault |
| GND | Abbreviation for ground connection |
| GripForce | Setting the gripping force |
| Offset | Correction value |
| PositionTolerance | Tolerance range for TeachPosition, BasePosition and WorkPosition The value of the parameter acts in both directions. |
| ShiftPosition | ShiftPosition is a switching position between pre-positioning and gripper movement. |
| StatusWord | Summary of binary states of the product that can be returned as information to the control system. |
| Teach | Adoption of the ActualPosition as the TeachPosition. |
| TeachPosition | Taught-in workpiece position |
| Traversing routine | Defined procedure for movement of the gripper jaws |
| Travel path | Path on which the gripper jaws travel. |
| WorkpieceNo | Number of the selected workpiece recipe |
| WorkPosition | Inner jaw position Depending on the application, this can be the end position or the work position. |
| Workpiece loss detection | Function which, in case of workpiece loss, causes the product to move to the end position. |

Content

- 1 Supporting documents 5
 - 1.1 Notices and graphics in the installation and operating instructions 5
- 2 Safety notices 6
- 3 Proper use 7
- 4 Personnel qualification 8
 - 4.1 Electricians 8
 - 4.2 Specialists 8
 - 4.3 Instructed personnel 8
 - 4.4 Service personnel 8
 - 4.5 Additional qualifications 8
- 5 Product description 9
 - 5.1 Possible applications 9
 - 5.2 Type plate 9
 - 5.3 Use in applications 10
- 6 Functional description 11
 - 6.1 LED status display 12
 - 6.2 Control 12
 - 6.3 Verified configuration examples 12
 - 6.4 Self-locking mechanism 12
- 7 Technical data 13
- 8 Accessories/scope of delivery 13
- 9 Transportation/storage/preservation 13
- 10 Installation 14
 - 10.1 Installing the product 15
 - 10.2 Installing HRC-03-117137 16
 - 10.3 Installing HRC-03-125035 17
 - 10.4 Safe shutoff for products with IO-Link 18
 - 10.5 Installing the energy supply 19
 - 10.5.1 HRC-03-100688 pin assignment 20
 - 10.5.2 HRC-03-116787 pin assignment 20
 - 10.5.3 HRC-03-117137 pin assignment 20
 - 10.5.4 HRC-03-118505 pin assignment 21
 - 10.5.5 HRC-03-125035 pin assignment 21
 - 10.5.6 HRC-03-126649 pin assignment 21
 - 10.5.7 HRC-03-126895 pin assignment 22
 - 10.5.8 HRC-03-126897 pin assignment 22
 - 10.5.9 HRC-03-126902 pin assignment 22
 - 10.5.10 B12-Y-5IL Y-cable pin assignment 23
 - 10.5.11 HRC-03-133316 pin assignment 24
 - 10.5.12 HRC-03-148656 pin assignment 24
 - 10.6 Switch between PNP and NPN 25
 - 10.7 Static charge 26
 - 10.8 Heat dissipation 26
 - 10.9 Installing accessories 26
- 11 Digital commissioning 27
 - 11.1 Restart 27
 - 11.2 Switching sequence 27
 - 11.2.1 Current supply profile of gripping process 28
 - 11.3 Cold start 28

EN / 2023-12-05
DDOC00266 / k

| | | |
|---------|---|----|
| 11.4 | Minimum travel path | 28 |
| 12 | Commissioning the IO-Link | 29 |
| 12.1 | Process data | 29 |
| 12.2 | IODD Import | 30 |
| 12.3 | Handshake Data Transfer Method..... | 30 |
| 12.4 | Parameters | 31 |
| 12.4.1 | ControlWord..... | 31 |
| 12.4.2 | DeviceMode | 33 |
| 12.4.3 | WorkpieceNo | 35 |
| 12.4.4 | PositionTolerance | 35 |
| 12.4.5 | GripForce | 36 |
| 12.4.6 | TeachPosition..... | 36 |
| 12.4.7 | StatusWord..... | 37 |
| 12.4.8 | Diagnosis..... | 38 |
| 12.4.9 | ActualPosition | 38 |
| 12.5 | Cold start | 39 |
| 12.6 | Minimum travel path | 39 |
| 12.7 | Easy Startup | 39 |
| 12.8 | Quickstart Basic Parameters | 40 |
| 12.9 | Starting the gripping movement..... | 41 |
| 12.10 | Repeated movements in the same direction..... | 41 |
| 12.11 | Recipe examples | 42 |
| 12.11.1 | Save recipe..... | 42 |
| 12.11.2 | Loading a recipe..... | 43 |
| 13 | Operation..... | 44 |
| 13.1 | Operating Freedrive..... | 44 |
| 13.2 | Setting the gripping force..... | 45 |
| 13.3 | Emergency release | 46 |
| 14 | Gripping force charts..... | 46 |
| 15 | Error diagnosis | 47 |
| 15.1 | Status in LED display for IO-Link error | 49 |
| 15.2 | Status in LED display for Digital error | 49 |
| 16 | Table with acyclic data (ISDU) | 50 |
| 17 | Maintenance..... | 52 |
| 18 | Decommissioning/disposal | 52 |
| 19 | RoHS declaration..... | 53 |
| 20 | REACH declaration..... | 53 |
| 21 | Declaration of Incorporation | 54 |
| 22 | Declaration of Conformity | 55 |

1 Supporting documents

NOTICE



Read through the installation and operating instructions before installing or working with the product.

The installation and operating instructions contain important notes for your personal safety. They must be read and understood by all persons who work with or handle the product during any phase of the product lifetime.



The documents listed below are available for download on our website www.zimmer-group.com.

- Installation and operating instructions
 - Catalogs, drawings, CAD data, performance data
 - Information on accessories
 - Technical data sheets
 - General Terms and Conditions, including warranty information.
- ⇒ Only those documents currently available on the website are valid.

In these installation and operating instructions, "product" refers to the product designation on the title page!

1.1 Notices and graphics in the installation and operating instructions

DANGER



This notice warns of an imminent danger to the life and health of people. Ignoring these notices can lead to serious injury or even death.

- ▶ You absolutely must comply with the described measures for avoiding these dangers!
- ⇒ The warning symbols are assigned according to the type of danger.

WARNING



This notice warns of a situation that is potentially hazardous to personal health. Ignoring these notices can cause serious injury or damage to health.

- ▶ You absolutely must comply with the described measures for avoiding these dangers!
- ⇒ The warning symbols are assigned according to the type of danger.

CAUTION



This notice warns of a situation that is potentially hazardous to persons. Ignoring these notices can cause minor, reversible injuries.

- ▶ You absolutely must comply with the described measures for avoiding these dangers!
- ⇒ The warning symbols are assigned according to the type of danger.

NOTICE



This notice warns of possible material and environmental damage. Ignoring these notices can result in damage to the product or the environment.

- ▶ You absolutely must comply with the described measures for avoiding these dangers!
- ⇒ The warning symbols are assigned according to the type of danger.

INFORMATION



This category contains useful tips for handling the product efficiently. Failure to observe these tips will not result in damage to the product. This information does not include any information relevant to health or workplace safety.

2 Safety notices

CAUTION



Risk of injury and material damage in case of non-compliance

Installation, commissioning, maintenance and repairs may only be performed by qualified specialists in accordance with these installation and operating instructions.

The product is state-of-the-art.

It is fitted to industrial machines and is used to hold, transport and store workpieces.

The following are examples of situations in which the product may cause a hazard:

- The product is not properly installed, used or maintained.
- The product is not used for its designated purpose.
- The locally applicable regulations, laws, directives or guidelines are not observed.
- ▶ The product may only be used in accordance with these installation and operating instructions and the product's technical data. Any changes or additions to the intended use of the product, as well as modifications to the product, such as those in the following examples, require the written permission of the manufacturer:
 - Use of the product under extreme conditions, such as aggressive fluids or abrasive dusts
 - Additional drilled holes or threads
- ⇒ Zimmer GmbH shall accept no liability for any damage caused by improper use. The operator bears sole responsibility.
- ▶ Make sure that the power supply is disconnected before you mount, adjust, modify, maintain or repair the product.
- ▶ Whenever work is carried out on the product, make sure that the product cannot be actuated by mistake.
- ▶ Perform maintenance tasks, renovation work or attachment work outside of the machine's danger zone when possible.
- ▶ Do not reach into the operational range of the product.
- ▶ Observe the specified maintenance intervals and specifications regarding the quality of the operating material.
- ▶ When using the product under extreme conditions, adjust the maintenance interval according to the degree of contamination.

The suitability of the product for collaborative use can only be verified while using gripper fingers installed in factory condition.

- ▶ If using other gripper fingers, check the permitted maximum force and pressure values for collaborative operation.

CAUTION

Notes and handling regulations for electrostatically sensitive components

Electrostatically sensitive components are individual components, integrated circuits or assemblies that can be damaged by electrostatic fields or electrostatic discharge.

- ▶ When handling electrostatic components, make sure that persons, the work area and packaging are all fully grounded.
- ▶ Touch electronic components only in appropriately identified areas with conductive flooring and only if:
 - You are grounded by means of special bracelets.
 - You wear shoes that are suitable and approved for the discharge of electrostatic charges.
- ▶ Do not bring electronic assemblies into contact with plastics and parts of clothing that have plastic content.
- ▶ Store electronic assemblies on conductive underlays only.
- ▶ Do not install electronic assemblies in the vicinity of data back-up devices or monitors (monitor distance > 100 mm).
- ▶ Perform measurements on electronic assemblies only if:
 - The measuring instrument is grounded (e.g. via a ground conductor).
 - The measuring head is momentarily discharged before measuring with a floating measuring instrument.

3 Proper use
NOTICE

Material damage and malfunction in case of non-compliance

The product is only to be used in its original state with its original accessories, with no unauthorized changes and within the stipulated parameter limits and operating conditions.

Any other or secondary use is deemed improper.

- ▶ Operate the product only in compliance with the associated installation and operating instructions.
 - ▶ Operate the product only when it is in a technical condition that corresponds to the guaranteed parameters and operating conditions.
- ⇒ Zimmer GmbH shall accept no liability for any damage caused by improper use. The operator bears sole responsibility.

- The product is designed exclusively for electric operation using a 24 V DC power supply.
- The product must always be mounted on materials that dissipate heat.
- The product is intended for industrial use.
- The product is to be used as intended in enclosed rooms for temporary gripping, handling and holding.
- The product is not suitable for clamping workpieces during a machining process.
- Direct contact with perishable goods/food is not permitted.

4 Personnel qualification

WARNING



Injuries and material damage due to inadequate qualification

If inadequately qualified personnel perform work on the product, this can cause serious injuries and significant material damage.

- ▶ All work on the product must be performed by qualified personnel.
- ▶ Before working with the product, read the document in its entirety and make sure that you have understood everything.
- ▶ Observe country-specific accident prevention regulations and the general safety notices.

The following qualifications are a prerequisite for performing various work on the product.

4.1 Electricians

Electricians are able to perform work on electrical systems, can recognize and avoid possible dangers and know the relevant standards and provisions due to their technical training, knowledge and experience.

4.2 Specialists

Specialists are able to perform the assigned work, can recognize and avoid possible dangers and know the relevant standards and provisions due to their technical training, knowledge and experience.

4.3 Instructed personnel

Instructed personnel have been trained by the operating company on the tasks and possible dangers of improper behavior.

4.4 Service personnel

Service personnel are able to perform the assigned work and can recognize and avoid possible dangers due to their technical training, knowledge and experience.

4.5 Additional qualifications

Persons who work with the product must be familiar with the valid safety regulations and laws as well as the standards, guidelines and laws listed in this document.

Personnel who work with the product must have facility-issued authorization to commission, program, configure, operate, maintain and also decommission this product.

5 Product description

CAUTION



Reduction of the gripping force can cause personal injury and material damage

When flexible components are gripped, the gripping force of the product is reduced.

Reduced gripping force can lead to personal injury or material damage, because the components that are being gripped can no longer be securely gripped and transported.

NOTICE



► Make sure that the setting of the gripping force and the selection of the gripper finger length are correct to prevent incorrect bracing of the gripper jaws.

⇒ An incorrect configuration or selection can lead to malfunction

5.1 Possible applications

Outside gripping

The product can be used for outside gripping.

MoveToWork command

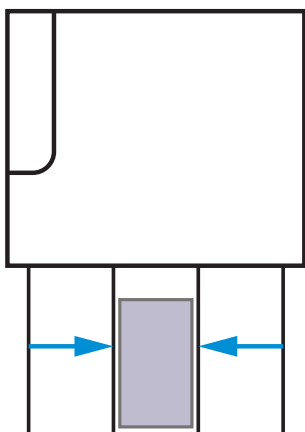

Inside gripping

The product can be used for inside gripping.

MoveToBase command

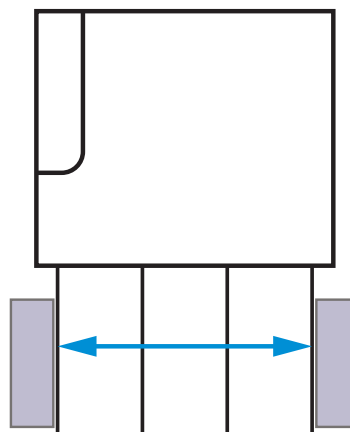

5.2 Type plate

A type plate is attached to the housing of the product.

The article number and confirmation number are shown on the type plate.

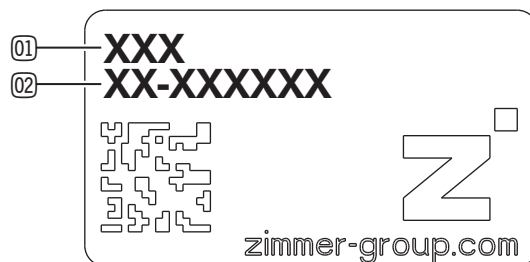

01 Article number

02 Confirmation number

5.3 Use in applications

The criteria listed below justify the suitability of the product for use in collaborative applications:

- The product has been designed in accordance with the specifications of ISO/TS 15066.
- The power of the motor in combination with the transmission design and the pre-assembled gripper jaws is not sufficient to generate a gripping force > 140 N upon vulnerable areas of the body.
- The gripping forces generated when gripping soft objects are significantly reduced, since the amount of dynamic force is lowered. Compliance with the maximum permitted gripping force has been verified using a suitable measuring instrument.
- The product is engineered to be inherently safe and is designed with rounded edges and shapes that prevent crushing and shearing points from being created.

Automation cell

Separated workspaces



Coexistence

Detection of presence

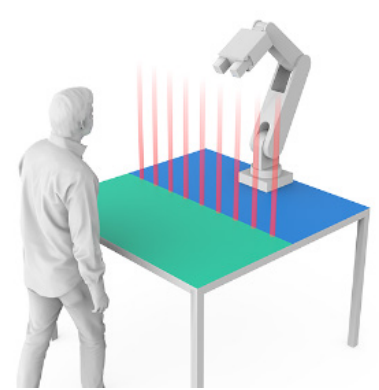

Cooperation

Zones of action

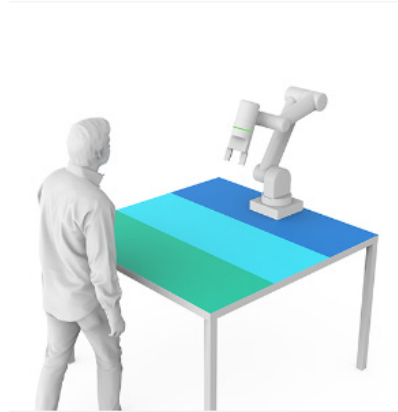

Collaboration

Shared workspaces

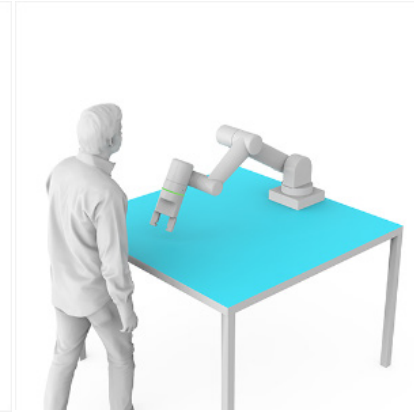

6 Functional description

The gripper jaws of the product are arranged parallel to each other on two opposing guide rails and can be moved relative to each other.

The force of the motor is transmitted by a worm drive. A pinion and a rack generate the movement of the gripper jaws and synchronize these movements.

Despite its small installation space, the product is suited for gripping a wide range of form-fit and frictional fit parts.

You can optionally adjust the gripping force to the workpiece by using the control system via IO-Link.

Depending on the installation size, the product can be integrated and controlled via IO-Link or digital inputs and outputs in existing control systems.

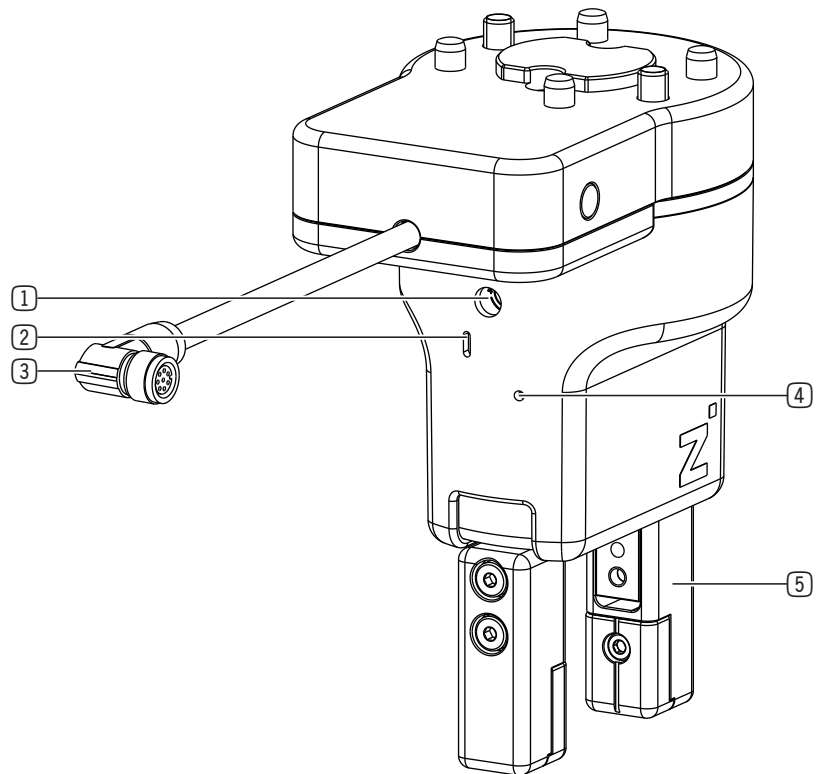

- ① Setting the gripping force
- ② LED display
- ③ Power supply
- ④ Emergency release
- ⑤ Gripper jaw

6.1 LED status display

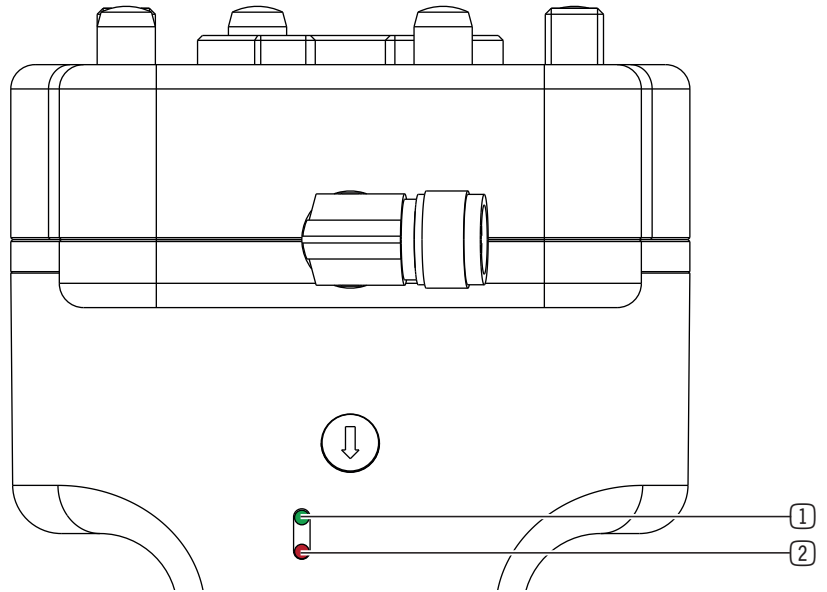

- ① Power/communication
- ② Error

6.2 Control

INFORMATION



- ▶ You can find the information in the technical data sheet on our website.
- ▶ Please contact Customer Service if you have any questions.

6.3 Verified configuration examples

INFORMATION



- ▶ You can find the information in the technical data sheet on our website.
- ▶ Please contact Customer Service if you have any questions.

6.4 Self-locking mechanism

INFORMATION



- ▶ The product has a mechanical self-locking mechanism to ensure that the workpiece remains held by the product in the event of power supply loss or failure (e.g. an emergency stop).
- ▶ Please contact Customer Service if you have any questions.

7 Technical data

INFORMATION



- ▶ You can find the information in the technical data sheet on our website.
- This data varies within the series, depending on the specific design.
- ▶ Please contact Customer Service if you have any questions.

8 Accessories/scope of delivery

INFORMATION



- If any accessories not sold or authorized by Zimmer GmbH are used, the function of the product cannot be guaranteed. Zimmer GmbH accessories are specifically tailored to the individual products.
- ▶ For optional accessories and those included in the scope of delivery, refer to our website.

9 Transportation/storage/preservation

- ▶ Transport and storage of the product must be done only with the original packaging.
- ▶ If the product has already been installed on the superordinate machine unit, care must be taken during transport to ensure that no unexpected movements can occur.
 - ▶ Before commissioning the product and after transport, check all power and communication connections as well as all mechanical connections.
- ▶ If the product is stored for an extended period, the following points are to be observed:
 - ▶ Keep the storage location as dust-free and dry as possible.
 - ▶ Avoid temperature fluctuations.
 - ▶ Avoid wind/drafts/water condensation formation.
 - ▶ Pack the product and do not expose it to direct sunlight during storage.
- ▶ Clean all components. There must be no soiling left on the components.
- ▶ Visually inspect all components.
- ▶ Remove all foreign substances.
- ▶ Properly remove potential corrosion spots.
- ▶ Close electrical connections using suitable covers.

10 Installation

WARNING



Risk of injury due to uncontrolled movements

Risk of injury in case of unexpected movement of the machine or system into which the product is to be installed.

- ▶ Switch off the energy supply of the machine before any work.
- ▶ Secure the power supply against being switched on unintentionally.
- ▶ Check the machine for any residual energy that may be present.

CAUTION



Risk of injury due to uncontrolled movements

Risk of injury in the event of uncontrolled movement of the product when the power supply is connected.

- ▶ Switch off the power supply to the machine before carrying out any work.
- ▶ Secure the power supply against being switched on unintentionally.
- ▶ Check the machine for any residual energy that may be present.

NOTICE



Installation may only be carried out by qualified personnel in accordance with these installation and operating instructions.

- ▶ Switch off the power supply before any assembly, installation or maintenance work.

Assembly requirements

| | | |
|---|------------------------------------|------|
| Permissible unevenness [mm] | Mounting surface length [mm] < 100 | 0.02 |
| | Mounting surface length [mm] > 100 | 0.05 |
| Strength class of the mounting screws (EN ISO 4762) | 8.8 | |

INFORMATION



Further installation information:

- The mounting screws are not included in the scope of delivery.
- Cleanliness of the mounting surfaces of the product and mounting piece (product grounding)

- ▶ Install the product on an appropriate mounting surface in accordance with the flatness specifications.
- ▶ Make sure that the mounting piece is sufficiently rigid.
- ▶ Please note the permitted tightening torques of the mounting screws at www.zimmer-group.com/de/td.

10.1 Installing the product

- ▶ Remove the countersunk screws.
- ▶ Remove the housing.
- ▶ Use a straight pin to position the product on the mounting piece.
- ▶ Mount the product on the robot flange using the mounting screws.
- ▶ Install the housing using the countersunk screws.

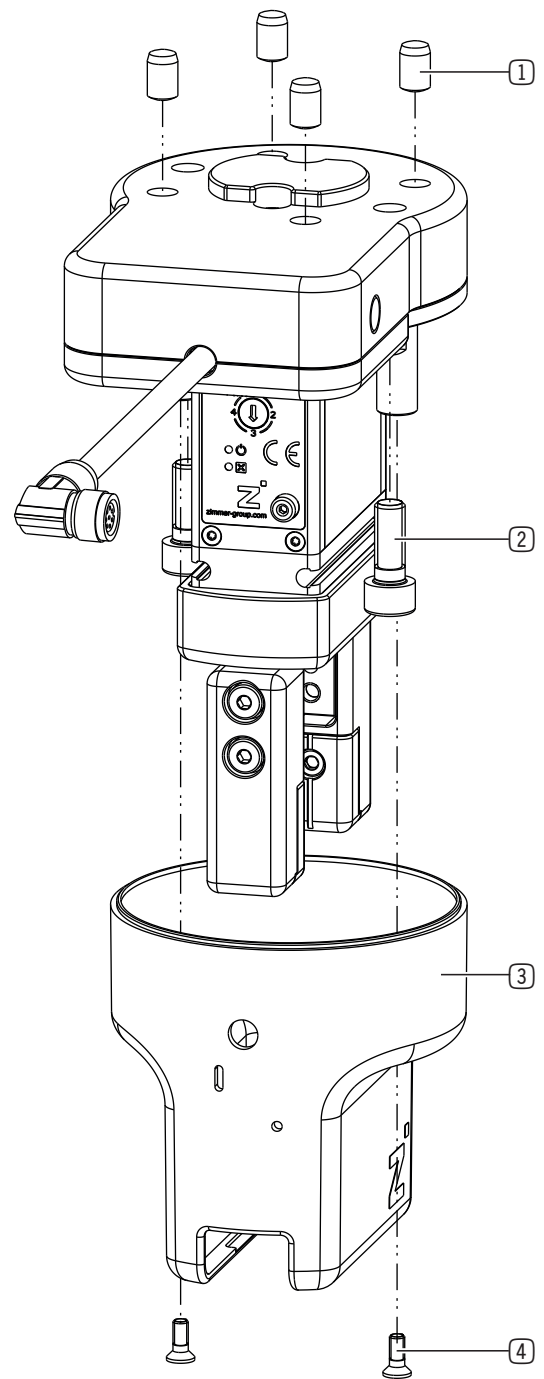

- ① Straight pins
- ② Mounting screw
- ③ Case
- ④ Countersunk screw

10.2 Installing HRC-03-117137

INFORMATION



► For more information on the “ClickSmart” plate, please see the technical data sheet from the manufacturer.

Further installation information:

- The mounting screws are not included in the scope of delivery.
- Strength class of the mounting screws is at least 8.8 (DIN EN ISO 4762)
- Use M3x16 mounting screws.

- Position the “ClickSmart” plate on the product.
- Loosely attach the mounting screws.
- Tighten the mounting screws crosswise.

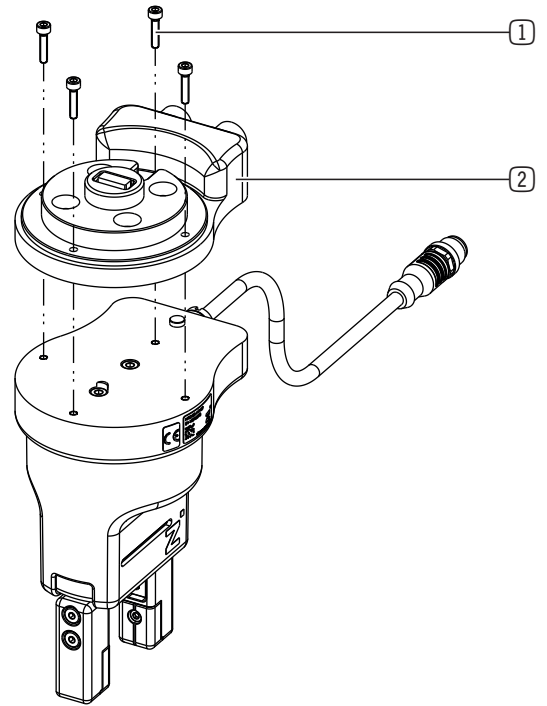

- ① Mounting screw
- ② “ClickSmart” plate

10.3 Installing HRC-03-125035

- ▶ Remove the countersunk screws.
- ▶ Remove the housing.
- ▶ Remove the mounting screws.
- ▶ Remove the adapter plate.
- ▶ Position the adapter plate on the mounting piece using the straight pin.
- ▶ Install the adapter plate on the mounting piece using the mounting screws.
- ▶ Position the product on the adapter plate using the straight pin.
- ▶ Mount the product on the adapter plate using the mounting screws.
- ▶ Install the housing using the countersunk screws.

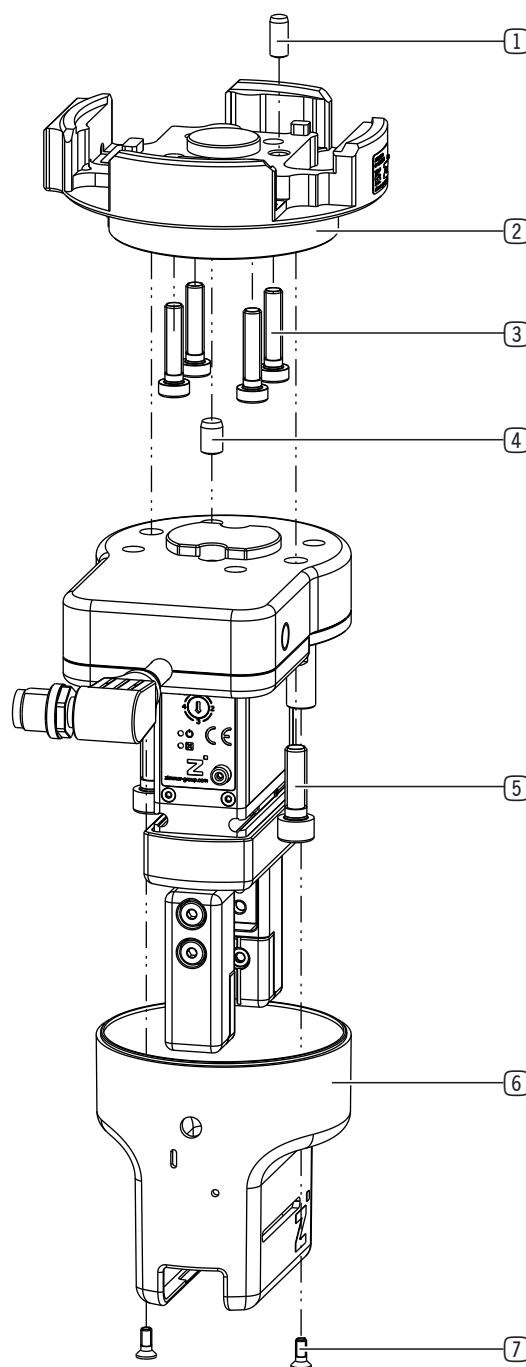

- ① Adapter plate straight pin
- ② Adapter plate mounting screw
- ③ Adapter plate
- ④ Straight pins
- ⑤ Mounting screw
- ⑥ Case
- ⑦ Countersunk screw

10.4 Safe shutoff for products with IO-Link

INFORMATION



For safe shutoff for IO-Link products, two contactors are switched in series with one auxiliary contact each. Here, the auxiliary contacts monitor the status of the contactors. If one contactor does not switch, the second contactor ensures safety. The malfunction can still be detected using the contacts.

The following figure shows the example of a circuit through which the IO-Link master cannot conduct the load current of the product.

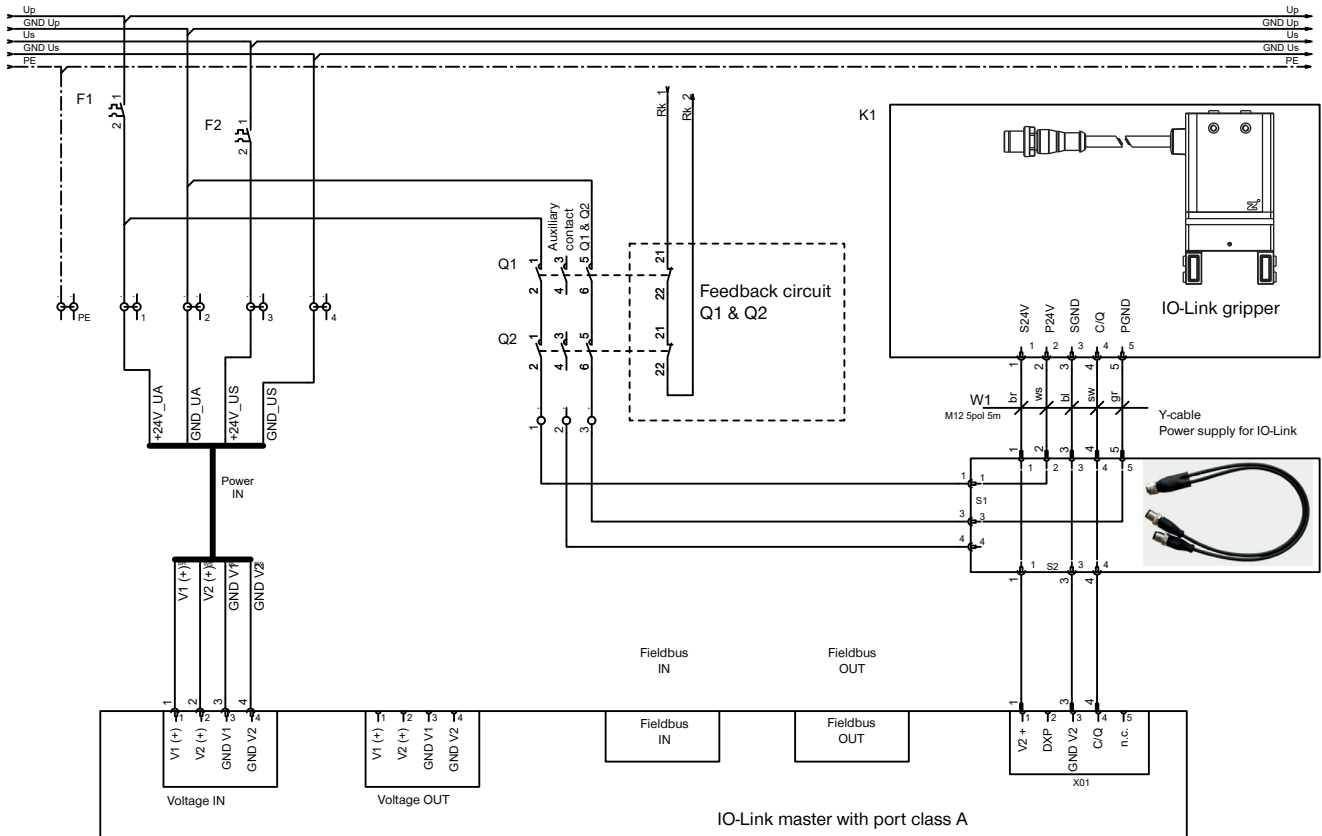

NOTICE



Without an externally fed voltage supply, the motor of the product cannot carry out an active movement and thus cannot carry out a hazardous movement.

There is no galvanic separation between the two voltage supplies (signal and power). There is a low-voltage connection via the ground (GND).

Because of the self-locking mechanism, the product remains in the last approached position, even if no voltage is supplied.

10.5 Installing the energy supply

CAUTION



Non-compliance may result in material damage.

Incorrect pin assignment can lead to malfunction or destruction of the product.

- ▶ Be absolutely certain to ensure correct pin assignment.

NOTICE



Non-compliance may result in material damage.

The cable mounted on the product can be subjected to a torsional angle of $+50^\circ$.

- ▶ Do not route the cable so that it is strained.
 - ▶ You must meet the minimum bending radius of 10x the outer diameter.
 - ▶ Secure free-hanging cables to prevent excessive motion loads or pinching.
 - ▶ The contacts of the energy supply must be dry, clean and undamaged at all times.
- ⇒ Damage to the contacts can result in malfunction of the product.

- ▶ Connect the power supply cable to the control system of the product.

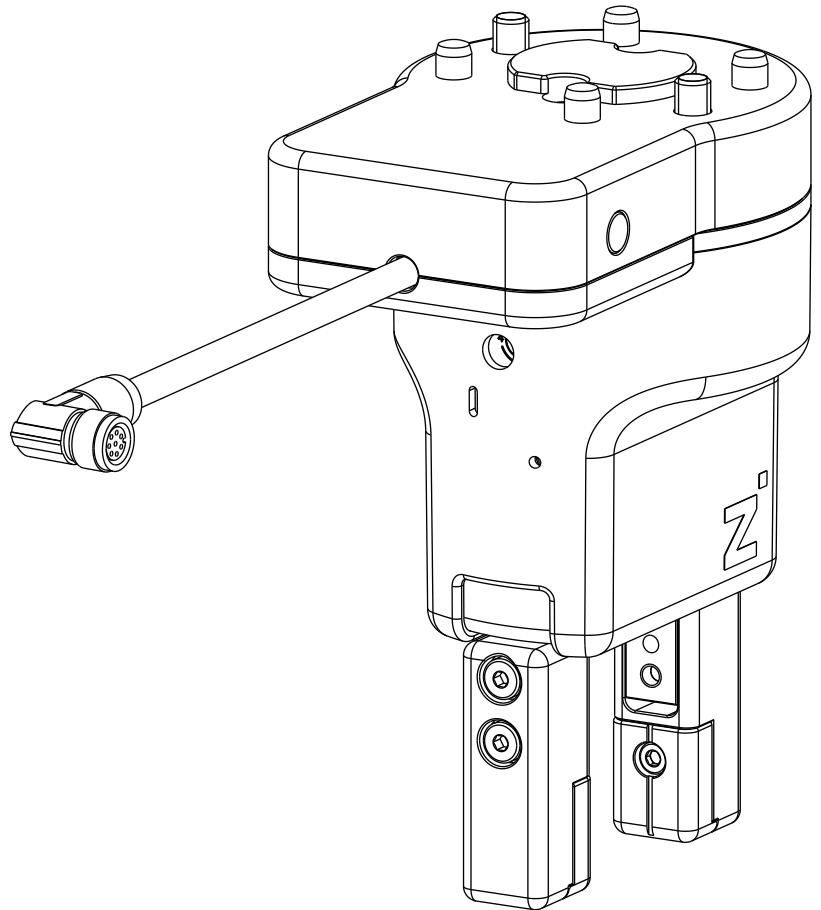

10.5.1 HRC-03-100688 pin assignment

| pin | Color | Function | Explanation |
|-----|--------|-----------------|---|
| 1 | White | GND | 0 V DC supply voltage |
| 2 | Brown | PWR | 24 V DC supply voltage |
| 3 | Green | Digital input 1 | Outward move command: Jaws move outward |
| 4 | Yellow | Digital input 2 | Inward move command: Jaws move inward |
| 5 | Gray | - | - |
| 6 | Pink | - | - |
| 7 | Blue | - | - |
| 8 | Red | Analog output | Jaw position 0–10 V DC |

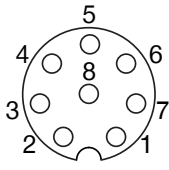

M8, 8-pin Socket/bracket

The inputs of the product are configured for NPN outputs of the control system.

10.5.2 HRC-03-116787 pin assignment

| pin | Color | Function | Explanation |
|-----|--------|-----------------|---|
| 1 | White | Analog output | 0 to 10 V DC output |
| 2 | Brown | - | - |
| 3 | Green | - | - |
| 4 | Yellow | Digital output | 24 V DC if Freedrive button is pressed. |
| 5 | Gray | PWR | 24 V DC supply voltage |
| 6 | Pink | Digital input 2 | Inward move command: Jaws move inward |
| 7 | Blue | Digital input 1 | Outward move command: Jaws move outward |
| 8 | Red | GND | 0 V DC supply voltage |

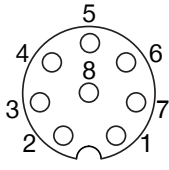

M8, 8-pin Socket/bracket

The inputs of the product are configured for 24 V DC outputs of the control system.

10.5.3 HRC-03-117137 pin assignment

| pin | Color | Function | Explanation |
|-----|--------|------------------|---|
| 1 | White | PWR | 24 V DC supply voltage |
| 2 | Brown | Digital input | <ul style="list-style-type: none"> 0 V DC = Outward move command: Jaws move outward 24 V DC = Inward move command: Jaws move inward |
| 3 | Green | GND 1 | 0 V DC supply voltage |
| 4 | Yellow | Analog output | Analog value |
| 5 | Gray | GND 2 | GND |
| 6 | Pink | Digital output 1 | BasePosition (jaws outward) |
| 7 | Blue | Digital output 2 | WorkPosition (jaws inward) |
| 8 | Red | GND 3 | GND |

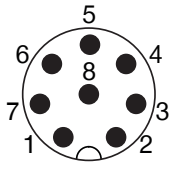

M8 8-pin plug

10.5.4 HRC-03-118505 pin assignment

| pin | Color | Function | Explanation |
|-----|--------|-----------------|---|
| 1 | White | Analog output | Jaw position 0–10 V DC |
| 2 | Brown | - | - |
| 3 | Green | - | - |
| 4 | Yellow | Digital output | Freedrive signal: 24 V DC if Freedrive button is pressed. |
| 5 | Gray | PWR | 24 V DC supply voltage |
| 6 | Pink | Digital input 2 | Inward move command: Jaws move inward |
| 7 | Blue | Digital input 1 | Outward move command: Jaws move outward |
| 8 | Red | GND | 0 V DC supply voltage |

M8, 8-pin Socket/bracket

The inputs of the product are configured for NPN outputs of the control system.

10.5.5 HRC-03-125035 pin assignment

| pin | Color | Function | Explanation |
|-----|--------|------------------|---|
| 1 | White | GND | 0 V DC supply voltage |
| 2 | Brown | PWR | 24 V DC supply voltage |
| 3 | Green | Digital input 1 | Outward move command: Jaws move outward |
| 4 | Yellow | Digital input 2 | Inward move command: Jaws move inward |
| 5 | Gray | - | - |
| 6 | Pink | - | - |
| 7 | Blue | Digital output 1 | BasePosition (jaws outward) |
| 8 | Red | Digital output 2 | WorkPosition (jaws inward) |

M8, 8-pin Connector/bracket

The inputs of the product are configured for 24 V DC outputs of the control system.

10.5.6 HRC-03-126649 pin assignment

| pin | Color | Function | Explanation |
|-----|--------|------------------|---|
| 1 | White | Analog output | Jaw position |
| 2 | Brown | - | - |
| 3 | Green | Digital output 2 | WorkPosition |
| 4 | Yellow | Digital output 1 | BasePosition |
| 5 | Gray | PWR | 24 V DC supply voltage |
| 6 | Pink | Digital input 1 | Outward move command: Jaws move outward |
| 7 | Blue | Digital input 2 | Inward move command: Jaws move inward |
| 8 | Red | GND | 0 V DC supply voltage |

M8, 8-pin Socket/bracket

The inputs of the product are configured for 24 V DC outputs of the control system.

10.5.7 HRC-03-126895 pin assignment

| pin | Color | Function | Explanation |
|-----|--------|------------------|---|
| 1 | White | Digital output 1 | BasePosition (jaws outward) |
| 2 | Brown | Digital input 1 | Outward move command: Jaws move outward |
| 3 | Green | Digital input 2 | Inward move command: Jaws move inward |
| 4 | Yellow | - | - |
| 5 | Gray | PWR | 24 V DC supply voltage |
| 6 | Pink | - | - |
| 7 | Blue | Digital output 2 | WorkPosition (jaws inward) |
| 8 | Red | GND | 0 V DC supply voltage |

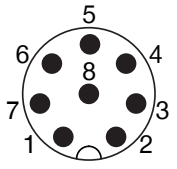

M8, 8-pin Connector/bracket

The inputs of the product are configured for 24 V DC outputs of the control system.

10.5.8 HRC-03-126897 pin assignment

| pin | Color | Function | Explanation |
|-----|-------|---------------|---|
| 1 | Black | PWR | 24 V DC supply voltage |
| 2 | Gray | - | - |
| 3 | Brown | Digital input | <ul style="list-style-type: none"> 0 V DC = Outward move command: Jaws move outward 24 V DC = Inward move command: Jaws move inward |
| 4 | White | Analog output | Jaw position 0–10 V DC |
| 5 | Blue | GND | 0 V DC supply voltage |

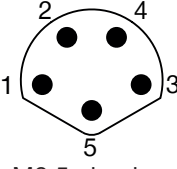

M8 5-pin plug

INFORMATION



The product requires hardware release 3.0 or higher in order to function.

10.5.9 HRC-03-126902 pin assignment
INFORMATION

► Note the deviation from the IO-Link port class B specification: There is no electrical isolation between the actuator and sensor voltage in the product.

⇒ An optional B12 Y-cable allows electrical isolation from the perspective of the IO-Link master.

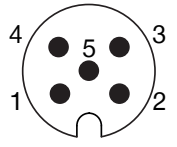
| pin | Color | Function | Explanation |
|-----|-------|----------------|--|
| 1 | Brown | 24 V DC sensor | 24 V DC supply voltage for IO-Link communication |
| 2 | White | PWR actuator | 24 V DC supply voltage for actuator |
| 3 | Blue | GND sensor | 0 V DC supply voltage for IO-Link communication |
| 4 | Black | C/Q | IO-Link communication |
| 5 | Gray | GND actuator | 0 V DC supply voltage for actuator |



M12 5-pin plug

10.5.10 B12-Y-5IL Y-cable pin assignment

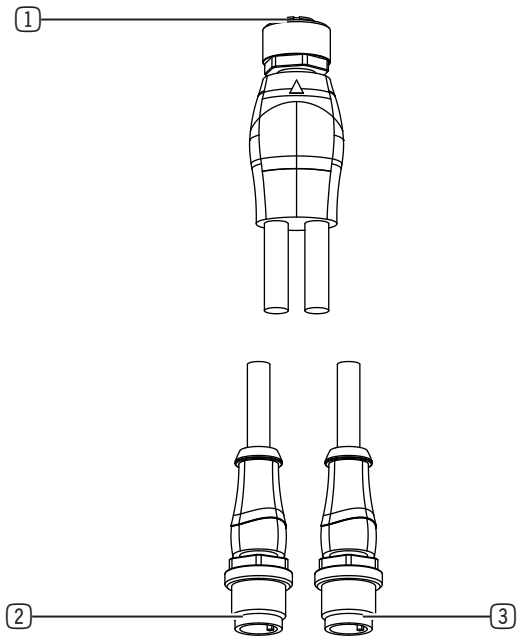

- ① Socket
- ② Plug 1
- ③ Plug 2

| pin | Color | Function | Explanation |
|-----|-------|----------------|--|
| 1 | Brown | 24 V DC sensor | 24 V DC supply voltage for IO-Link communication |
| 2 | White | PWR actuator | 24 V DC supply voltage for actuator |
| 3 | Blue | GND sensor | 0 V DC supply voltage for IO-Link communication |
| 4 | Black | C/Q | IO-Link communication |
| 5 | Gray | GND actuator | 0 V DC supply voltage for actuator |

M12 5-pin socket

| pin | Color | Function | Explanation |
|-----|-------|--------------|-------------------------------------|
| 1 | Brown | - | - |
| 2 | White | PWR actuator | 24 V DC supply voltage for actuator |
| 3 | Blue | - | - |
| 4 | Black | - | - |
| 5 | Gray | GND actuator | 0 V DC supply voltage for actuator |

M12 5-pin plug 1

| pin | Color | Function | Explanation |
|-----|-------|----------------|--|
| 1 | Brown | 24 V DC sensor | 24 V DC supply voltage for IO-Link communication |
| 2 | White | - | - |
| 3 | Blue | GND sensor | 0 V DC supply voltage for IO-Link communication |
| 4 | Black | C/Q | IO-Link communication |
| 5 | Gray | - | - |

M12 5-pin plug 2

10.5.11 HRC-03-133316 pin assignment

| pin | Color | Function | Explanation |
|-----|--------|------------------|---|
| 1 | - | - | - |
| 2 | - | - | - |
| 3 | Green | Digital output 2 | BasePosition (jaws outward) |
| 4 | Yellow | Digital output 1 | WorkPosition (jaws inward) |
| 5 | Gray | PWR | 24 V DC supply voltage |
| 6 | Pink | Digital input 2 | Outward move command: Jaws move outward |
| 7 | Blue | Digital input 1 | Inward move command: Jaws move inward |
| 8 | Red | GND | 0 V DC supply voltage |

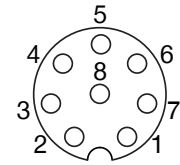

M8, 8-pin Socket/bracket

The inputs of the product are configured for NPN outputs of the control system.

10.5.12 HRC-03-148656 pin assignment

| pin | Color | Function | Explanation |
|-----|-------|------------------|---|
| 1 | White | Digital input 1 | Outward move command: Jaws move outward |
| 2 | Brown | Digital input 2 | Inward move command: Jaws move inward |
| 3 | - | - | - |
| 4 | - | - | - |
| 5 | Gray | Digital output 1 | BasePosition (jaws outward) |
| 6 | Pink | Digital output 2 | WorkPosition (jaws inward) |
| 7 | Blue | PWR | 24 V DC supply voltage |
| 8 | Red | GND | 0 V DC supply voltage |

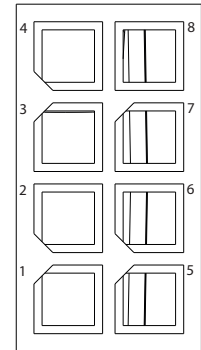

0430200801 8-pin Socket

The inputs of the product are configured for 24 V DC outputs of the control system.

10.6 Switch between PNP and NPN

INFORMATION



This function is only available for digital versions of this series.
The inputs and outputs of the product are shipped set to PNP.

- ▶ Remove the mounting screws using a Torx screwdriver.

| Design size | Key size |
|-------------|----------|
| HRC-03 | TX10 |

- ▶ Remove the cover.

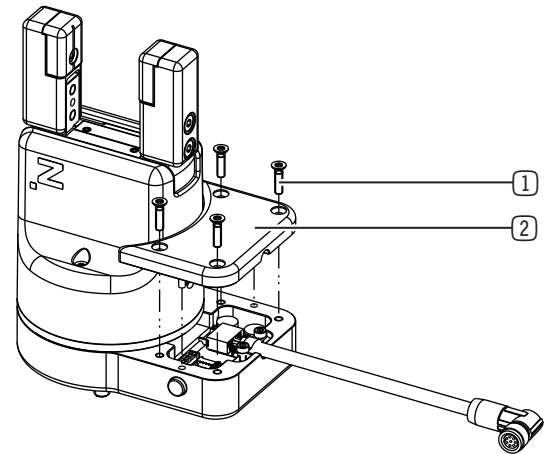

- ① Mounting screw
- ② Cover

- ▶ Plug in the jumpers.
- ▶ Install the cover with the mounting screws.

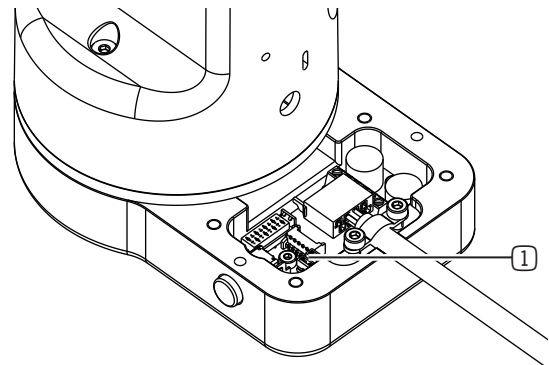

- ① Jumper

10.7 Static charge

CAUTION



Material damage from static charge

Material damage can result from contact of ESD-sensitive parts with the product.

- ▶ It is mandatory to ground the gripper fingers.

Grounding is also recommended in applications that require high EMC shielding.

The movement of the gripper jaws creates low voltages as a result of static charging. These charges cannot be dissipated if the product is mounted on an insulating surface and if discharge is also not possible through the workpiece.

10.8 Heat dissipation

In the event of high ambient temperatures, the product must be installed on heat-dissipating materials.

If the product is operated under very high ambient temperatures and with fast clock cycles on an ongoing basis, this might reduce its service life.

INFORMATION



- ▶ The cycle time must therefore be reduced as the temperature increases.

10.9 Installing accessories

NOTICE



- ▶ Before installing an accessory, make sure it is suitable for use with the selected variant.
- ▶ You can find information on our website.
- ▶ Please contact Customer Service if you have any questions.

11 Digital commissioning

11.1 Restart

NOTICE



- ▶ Make sure that there is no signal present at digital inputs 1 and 2 when the product is restarted.
- ⇒ The product is ready to operate when the green LED lights up.
- ⇒ The product can be moved a few milliseconds after voltage is supplied.

11.2 Switching sequence

A movement in the desired direction occurs when the corresponding signal is at a high level. After a high level is detected, the gripper movement occurs until the gripping process ends.

- ▶ Reset the corresponding signal after the movement is complete. The signal must be reset before a signal is emitted in the opposite direction.
- ▶ Observe a break time of 10 ms between the reset of the signal and the next command.

The current jaw position is scaled from 0 V DC (external) to 10 V DC (internal) and is issued via the analog output.

INFORMATION



The following figure shows the controller for NPN.

When controlling for PNP, the command starts at low level instead of high level.

- ▶ You can find the information about the controller on the technical data sheet for the MATCH robot module on our website.

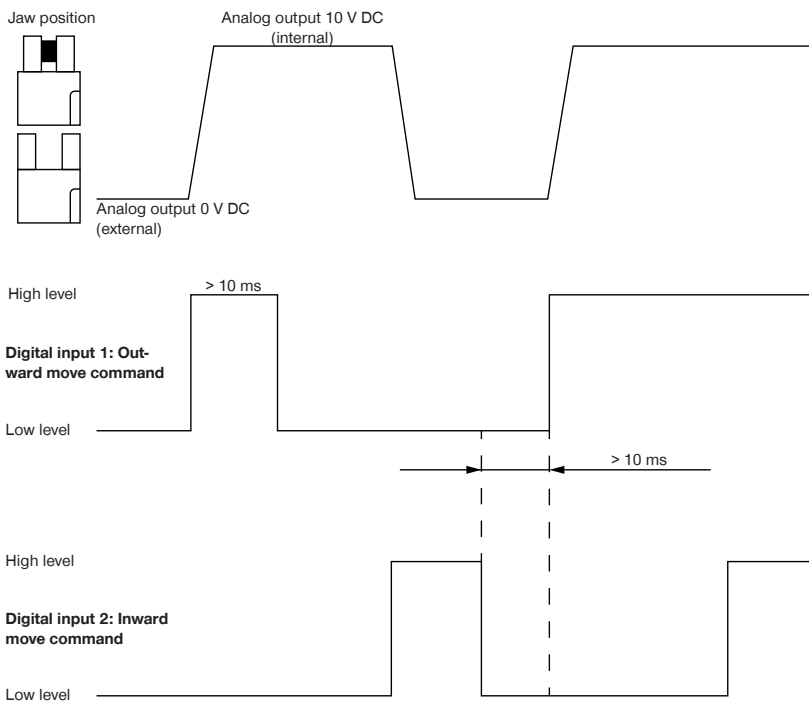

11.2.1 Current supply profile of gripping process

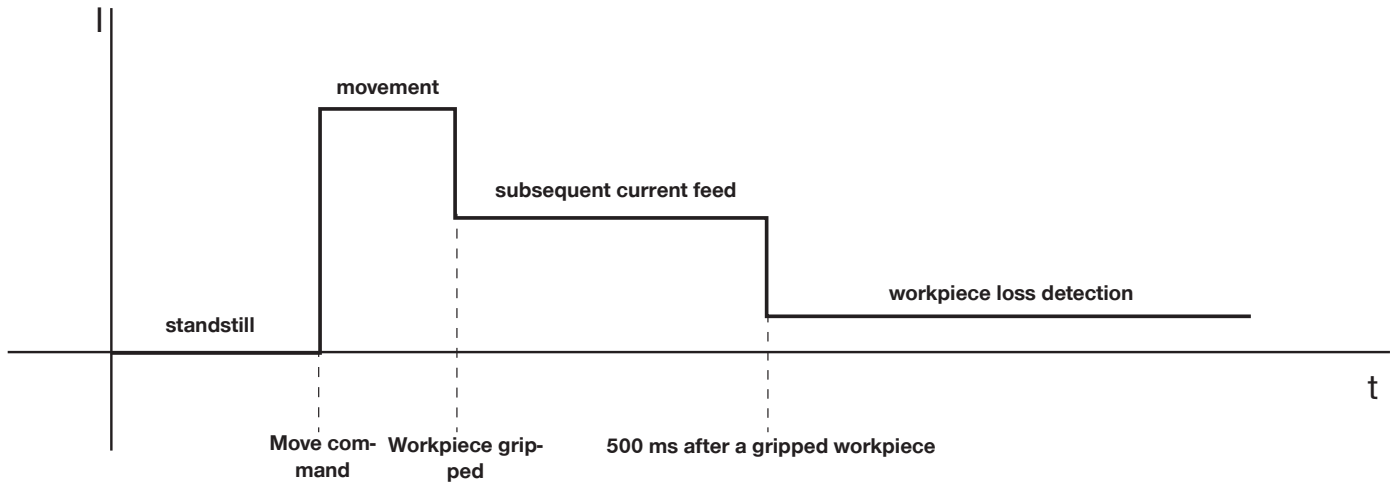

NOTICE



If the workpiece is lost, the product moves to the end position.

11.3 Cold start

For proper function, Zimmer GmbH recommends that the actuator and sensor voltage be supplied with power separately. The sensor supply must be switched on first.

As soon as the product is communicating with the PLC, the actuator power supply can be switched on. Depending on the application, simultaneous activation of both voltages is also possible.

INFORMATION



If the sensor supply is disconnected, the C/Q signal (IO-Link) must be disconnected as well.

11.4 Minimum travel path

The product requires a certain minimum travel path to move to the desired position.

| Design size | Minimum travel path per gripper jaw [mm] |
|-------------|--|
| HRC-03 | 0.5 |

12 Commissioning the IO-Link

12.1 Process data

There is an option to control the product only with the process data that is transmitted in each cycle.

INFORMATION



The terms process data input and output are to be understood from the perspective of the gripper.

| Name | Data type |
|-------------------|-----------|
| ControlWord | UINT16 |
| DeviceMode | UINT8 |
| WorkpieceNo | UINT8 |
| TeachPosition | UINT16 |
| GripForce | UINT8 |
| PositionTolerance | UINT8 |

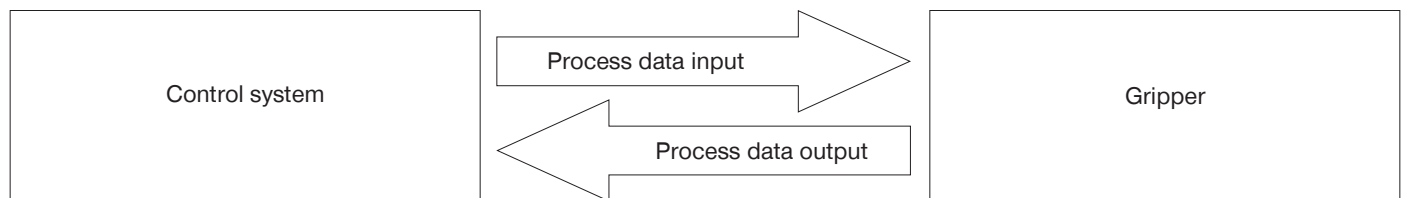

| Name | Data type |
|----------------|-----------|
| StatusWord | UINT16 |
| Diagnosis | UINT16 |
| ActualPosition | UINT16 |

12.2 IODD Import

- ▶ Import the IODD (device description) into the control system.
 - ▶ Go to our website.
 - ▶ Select the desired product.
 - ▶ Download the corresponding .zip file via the Download IODD link.
- ⇒ You will need the .zip file for import into the control system.
- ⇒ As soon as the hardware configuration is complete and the IO-Link connection to the product is established, data will be displayed in the process input data.
- ⇒ Some control systems demand a byte swap to bring this process data into a logical sequence.
- ▶ Look at bit 6 (GripperPLCActive) in the StatusWord to determine whether a byte swap is necessary.
 - ▶ Determine whether bit 6 is active in the first or second byte of the StatusWord.
 - ⇒ Bit 6 is active in the first byte: The bytes already have the correct sequence.
 - ▶ Continue with the commissioning.
 - ⇒ Bit 6 is active in the second byte.
 - ▶ Apply a byte swap, refer to the "StatusWord" section.

INFORMATION



The product is controlled via IO-Link by means of the cyclical process data as well as the acyclic service data with a cycle time of 5 ms.

- ▶ It is mandatory to verify the process data!

12.3 Handshake Data Transfer Method

The handshake method makes it possible to transfer the process data about the product. All process data described in the following sections must be transferred with the handshake.

- ▶ Send the ControlWord = 0x0001 to the product.
- ⇒ The data transfer was started.
- ▶ Check the response of the product by using Statusbit 12 = TRUE (data transfer OK).
- ▶ Send the ControlWord = 0x0000 to stop the data transfer.
- ⇒ The data transmission is complete when the product sends back Statusbit 12 = DataTransferOK = FALSE.

INFORMATION



- ▶ For examples, refer to the "Quickstart Basic Parameters" section.

12.4 Parameters

12.4.1 ControlWord

NOTICE



In the ControlWord parameter, only one single bit or the value 0 may be set at a time. Only the values listed in the following table are valid.

| Parameter | Decimal value | Hexadecimal value |
|--------------------|---------------|-------------------|
| DataTransfer | 1 | 0x0001 |
| WritePDU | 2 | 0x0002 |
| ResetDirectionFlag | 4 | 0x0004 |
| Teach | 8 | 0x0008 |
| Adjust | 128 | 0x0080 |
| MoveToBase | 256 | 0x0100 |
| MoveToWork | 512 | 0x0200 |
| ErrorReset | 32768 | 0x8000 |

| Name | ControlWord |
|-------------|-------------|
| Data format | UINT16 |
| Permission | Write |
| Transfer | Cyclical |
| Value range | 0 - 65535 |

| | Bit 15 | Bit 14 | Bit 13 | Bit 12 | Bit 11 | Bit 10 | Bit 9 | Bit 8 |
|--------|------------|--------|--------|--------|--------|--------------------|------------|--------------|
| Byte 1 | ErrorReset | - | - | - | - | - | MoveToWork | MoveToBase |
| | Bit 7 | Bit 6 | Bit 5 | Bit 4 | Bit 3 | Bit 2 | Bit 1 | Bit 0 |
| Byte 2 | Adjust | - | - | - | Teach | ResetDirectionFlag | WritePDU | DataTransfer |

Bit 0: DataTransfer

Setting this bit causes the product to acquire the data transmitted in the process data ("WorkpieceNo" = 0) or the data stored in the workpiece data ("WorkpieceNo" = 1 to 32) as the active data set.

Setting this bit tells the product that the direction flag needs to be reset. This function is available starting from Application Firmware Version SWA000170_A00, see Chapter "Table of acyclic data (ISDU)" Index 0x0017.

Bit 1: WritePDU

Setting this bit tells the product that it should write the current process data to the selected workpiece recipe.

Bit 2: ResetDirectionFlag

Setting this bit tells the product that the direction flag needs to be reset. This makes a repeated movement to a position possible. This is logical during a switchover of workpiece recipes.

NOTICE

- ▶ Please note that the product can be damaged from overheating due to repeated, prompt movement to the end stop or with a gripped workpiece.

Bit 3: Teach

Setting this bit tells the product to save the current position as the TeachPosition in the selected WorkpieceNo. This only works if there is no "0" that is transmitted in the workpiece number.

Bit 7: Adjust

Setting this bit causes a readjustment of the jaw end positions if no other bit is set in the control word.

Bit 8: MoveToBase

Setting this bit tells the product to move toward the BasePosition.

Bit 9: MoveToWork

Setting this bit tells the product to move toward the WorkPosition.

Bit 15: ErrorReset

This bit can be used to acknowledge all errors that can be reset. Whether an error can be reset is shown in the "Error Diagnosis" section.

12.4.2 DeviceMode

INFORMATION



DeviceMode is used to select one of the following travel modes: universal operation, outside gripping or inside gripping. Zimmer GmbH recommends DeviceMode 63, 73 and 103.

⇒ For the A-variants of the product, only DeviceMode 60, 70 and 100 are available.

| Input | Mode | Description |
|-------|--|--|
| 63 | Outside gripping with subsequent current feed | Like Mode 60, but with an activated subsequent current feed for a time of 500 ms when the direction of movement is Work. To achieve the best gripping results, the gripped workpiece must be transported further during the subsequent current feed. |
| 73 | Inside gripping with subsequent current feed | Like Mode 70, but with an activated subsequent current feed for a time of 500 ms when the direction of movement is Base. To achieve the best gripping results, the gripped workpiece must be transported further during the subsequent current feed. |
| 103 | Universal operation with subsequent current feed | Like Mode 100, but with an activated subsequent current feed for a time of 500 ms in both directions. To achieve the best gripping results, the gripped workpiece must be transported further during the subsequent current feed. |
| 60 | Outside gripping | Inward with the desired gripping force and speed, outward at high speed. |
| 70 | Inside gripping | Outward with the desired gripping force and speed, inward at high speed. |
| 100 | Universal mode | Inside and outside gripping, both movements at the same speed. |

| Name | DeviceMode |
|-------------|--------------------------|
| Data format | UINT8 |
| Permission | Write |
| Transfer | Cyclical |
| Value range | 60, 63, 70, 73, 100, 103 |

12.4.2.1 Current feed profile for a gripping process with DeviceMode 63, 73, 103

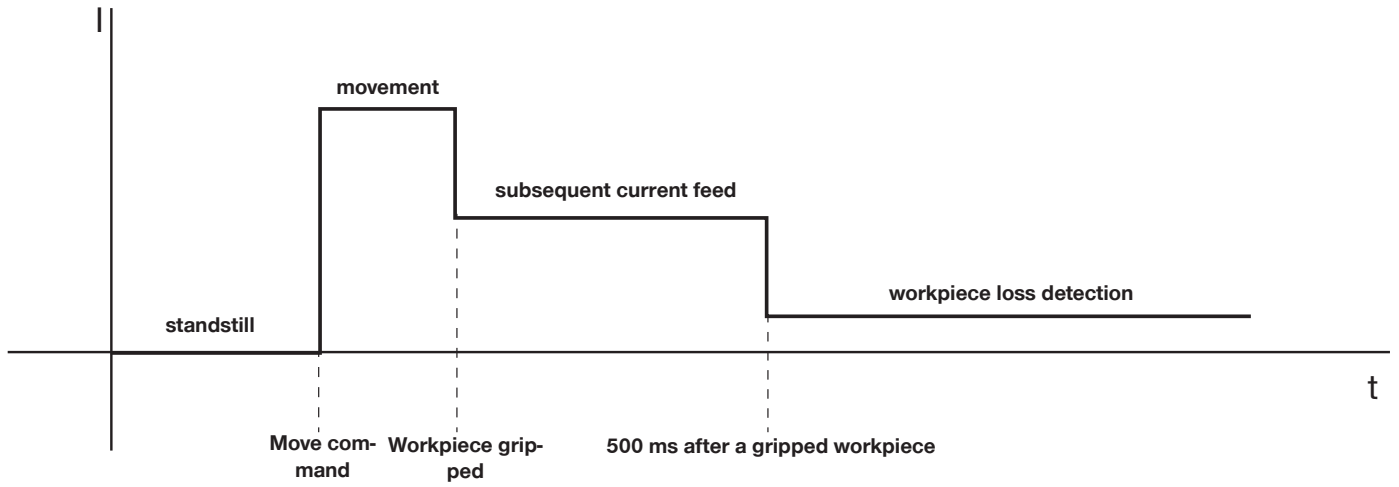

NOTICE



In case of workpiece loss, the product moves to the end position and outputs a message.

12.4.3 WorkpieceNo

The workpiece number is used for selecting the previously stored workpiece data, as well as for selecting the WorkpieceNo data record in which the current process data is stored.

WorkpieceNo enables individual workpieces to be taught in to the product very quickly if the recipes are not managed on the control system.

INFORMATION



For example codes, refer to the "Quickstart Basic Parameters" and "Recipe Examples" sections.

| Name | WorkpieceNo |
|-------------|-------------|
| Data format | UINT8 |
| Permission | Write |
| Transfer | Cyclical |
| Value range | 0 - 32 |

At a value > 0, the corresponding workpiece recipe is loaded in the product.

12.4.4 PositionTolerance

Used to configure the position tolerance with a resolution of 0.01 mm.

Thus, the value range of 0 to 255 can be used to set a maximum tolerance of 2.55 mm in both directions.

INFORMATION



Example:

For TeachPosition 1500 (15 mm), PositionTolerance 150 lets you configure a tolerance of 1.5 mm in both directions.

This means that the TeachPosition range starts at 13.5 mm and goes all the way up to 16.5 mm.

| Name | PositionTolerance |
|-------------|-------------------|
| Data format | UINT8 |
| Permission | Write |
| Transfer | Cyclical |
| Value range | 0 to 255 |

12.4.5 GripForce

The product can use various gripping forces and gripping speeds to achieve an optimized flow of the gripping process. Since the product generates gripping force from the gripping speed and the amperage, the gripping force setting also conversely influences the gripping speed and amperage. The gripping force can be adjusted in four stages.

INFORMATION



- ▶ For the values for the gripping force, refer to the technical data sheet on our website.
- ▶ This data varies within the series, depending on the specific design.
- ▶ Please contact Customer Service if you have any questions.

| Name | GripForce | |
|-------------|-----------|---------|
| Data format | UINT8 | |
| Permission | Write | |
| Transfer | Cyclical | |
| Value range | 1 | Level 1 |
| | 2 | Level 2 |
| | 3 | Level 3 |
| | 4 | Level 4 |

12.4.6 TeachPosition

The TeachPosition notifies the product of the expected position of the workpiece. The tolerance range around the expected position of the workpiece is defined using the PositionTolerance. The StatusWord notifies the control system of whether the desired workpiece has been gripped. The user can monitor this work step with the Teach bit.

- ▶ Use the following values:

| Product | BasePosition | WorkPosition | TeachPosition |
|---------------|--------------|--------------|----------------|
| HRC-03-126902 | 0 | 2000 | 0 to max. 2000 |

| Name | TeachPosition |
|-------------|-------------------------------------|
| Data format | UINT16 |
| Permission | Write |
| Transfer | Cyclical |
| Value range | 0 to max. jaw stroke of the product |

12.4.7 StatusWord

StatusWord structure:

| | Bit 15 | Bit 14 | Bit 13 | Bit 12 | Bit 11 | Bit 10 | Bit 9 | Bit 8 |
|--------|--------|-----------------------|-----------------------|----------------|------------------------|-------------------|--------------------|-------------------|
| Byte 1 | Error | ControlWord 0x0200 | ControlWord 0x0100 | DataTransferOK | Undefined- Position | WorkPo- sition | TeachPo- sition | BasePo- sition |
| | Bit 7 | Bit 6 | Bit 5 | Bit 4 | Bit 3 | Bit 2 | Bit 1 | Bit 0 |
| Byte 2 | - | Gripper- PLCActive | - | - | - | - | - | - |

Bit 6: GripperPLCActive

Active as soon as the product has booted up after the cold boot. This bit can be used to verify a "byte swap."

Bit 8: BasePosition

Active if the product is set to BasePosition.

Bit 9: TeachPosition

Active if the product is set to TeachPosition.

Bit 10: WorkPosition

Active if the product is set to WorkPosition.

Bit 11: UndefinedPosition

Active if the product is not set to TeachPosition, WorkPosition or BasePosition.

Bit 12: DataTransferOK

This bit is used for data transmission using the handshake. Active as soon as the product has taken over the data using the parameter ControlWord = 1 (decimal).

Bit 13: ControlWord 0x0100

This bit is a direction flag. Active if the last motion task was carried out toward BasePosition.

Bit 14: ControlWord 0x0200

This bit is a direction flag. Active if the last motion task was carried out toward WorkPosition.

Bit 15: Error

Active if the product has an active error. The error message can be determined using Diagnosis.

| Name | StatusWord |
|-------------|------------|
| Data format | UINT16 |
| Permission | Read |
| Transfer | Cyclical |
| Value range | 0 - 65535 |

12.4.7.1 Acknowledging an error

If the product has a fault, the error bit is set in the status word.

- ▶ Acknowledge the error by sending ControlWord 0x8000.

NOTICE



Not all errors can be reset. For some errors, the error message is not reset after acknowledgment.

In this case, wait until correct values are sent to the product.

Example: Overheating error

INFORMATION



- ▶ Use StatusWord to verify correct gripping.
- ▶ The TeachPosition tolerance can be adjusted in another process parameter.
- ▶ For sensing the correct position via the ACTUAL position, the tolerances and fluctuations of the value must be observed during programming.

12.4.8 Diagnosis

The value returned in Diagnosis corresponds to the error code (see "Error Diagnosis" section).

| Name | Diagnosis |
|-------------|-----------|
| Data format | UINT16 |
| Permission | Read |
| Transfer | Cyclical |
| Value range | 0 - 65535 |

12.4.9 ActualPosition

ActualPosition corresponds to the current position of the gripper jaws relative to the full stroke.

The value is specified with a resolution of 0.01 mm.

The values can move between the BasePosition (minimum values) and the WorkPosition (maximum values).

| Product | BasePosition | WorkPosition | TeachPosition | Accuracy [mm] |
|---------------|--------------|--------------|----------------|---------------|
| HRC-03-126902 | 0 | 2000 | 0 to max. 2000 | ± 0.05 |

| Name | ActualPosition |
|-------------|-------------------------------------|
| Data format | UINT16 |
| Permission | Read |
| Transfer | Cyclical |
| Value range | 0 to max. jaw stroke of the product |

INFORMATION



- ▶ Use the StatusWord of the product to check whether a workpiece has been gripped correctly.
 - The position measurement resolution is 0.01 mm.
 - The accuracy of the position measurement depends on the installation size.
- ▶ During commissioning, be aware of fluctuations around the exact value if you use the ActualPosition parameter to detect the workpiece.

12.5 Cold start

For proper function, Zimmer GmbH recommends that the actuator and sensor voltage be supplied with power separately. The sensor supply must be switched on first.

As soon as the product is communicating with the PLC, the actuator power supply can be switched on. Depending on the application, simultaneous activation of both voltages is also possible.

INFORMATION



If the sensor supply is disconnected, the C/Q signal (IO-Link) must be disconnected as well.

12.6 Minimum travel path

The product requires a certain minimum travel path to move to the desired position.

| Design size | Minimum travel path per gripper jaw [mm] |
|---------------|--|
| HRC-03-126902 | 0.5 |

12.7 Easy Startup

Describes the process from switching on the product to the initial movement.

- ▶ Connect the product according to its assignment diagram.
- ⇒ The product reports the process parameters StatusWord, Diagnosis and ActualPosition immediately after the internal controller is booted up.
- ⇒ As soon as the PLCActive bit is registered in the StatusWord, the communication process can start.
- ▶ Transmit the process parameters to move the product.
 - DeviceMode
 - GripForce
- ▶ Transmit the parameters to the product with a handshake.

INFORMATION



▶ For more information please refer to the „Handshake Data Transfer Method“ section.

12.8 Quickstart Basic Parameters

In the following example, you see the first initialization of the product, the activation of the motor and the transmission of the process parameters.

```
// Initialization of the product
// Motor switch-on
// Initial move command
// = EasyStartUp Example

IF bStart = TRUE THEN
    iStep          := 10;
END_IF

CASE iStep OF

10:
    IF StatusBit.6 THEN          // Query for PLCActive bit in the StatusWord
        ControlWord          := 1; // Sends the DataTransfer bit in the ControlWord for initialization
        iStep                := 20; // Jump to the next step
    END_IF

20:
    IF StatusBit.12 THEN         // Query for DataTransferOK bit in the StatusWord
        ControlWord          := 0; // Reset of the initialization
        iStep                := 30; // Jump to the next step
    END_IF

30:
    IF NOT StatusWord.12 THEN
        DeviceMode          := 100; // Command to select the universal mode
        GripForce           := 4; // Gripping force setting
        ControlWord         := 1; // Data transfer to the product
        iStep               := 40; // Jump to the next step
    END_IF

40:
    IF StatusWord.12 THEN       // Query for DataTransferOK bit in the StatusWord
        ControlWord          := 0; // Reset the ControlWord
        iStep                := 50; // Jump to the next step
    END_IF

50:
    IF NOT StatusWord.12 THEN   // Query for DataTransferOK bit in the StatusWord
        ControlWord          := 512; // Handshake is completed,
        // Product moves to WorkPosition (0x0200 or 512(decimal) = MoveToWork)
        iStep                := 100;
    END_IF

100:
    ; // Continue with the program

END_CASE
```

12.9 Starting the gripping movement

- ▶ Send ControlWord 0x0200 so that the product moves towards the WorkPosition.
- ⇒ The gripper jaws move towards the inside.
- ▶ Send ControlWord 0x0100 so that the product moves towards the BasePosition.
- ⇒ The gripper jaws move towards the outside.
 - The motion task must be pending for as long as it takes until the desired position is reached.
 - The current motion task is canceled as a result of a new handshake.
- ⇒ When the product reaches the corresponding position, this is displayed in the StatusWord as follows:
 - The product is at the BasePosition: StatusWord bit 8 = TRUE
 - The product is at the TeachPosition: StatusWord bit 9 = TRUE
 - The product is at the WorkPosition: StatusWord bit 10 = TRUE

12.10 Repeated movements in the same direction

The StatusWord includes two static flag bits, each of which is set in alternation when the product moves in one direction. This prevents uncontrolled movements of the product in case of faulty data transmission.

Depending on the location of the positions, it is possible that the product may move multiple times in the same direction. For this purpose, the direction flags must be reset.

- ▶ Send the ControlWord = 0x0004 to delete the direction flags.
- ⇒ The direction flags are reset when the product answers with status bit 13 AND 14 = FALSE.

Program example for repeated movements in the same direction:

```
// Multiple movement in one direction in Structured Text (ST)
// The product is not capable of accepting multiple move commands in the same direction.
// That is why the direction flag has to be reset in the StatusWord.
// In this example, all process parameters are already correctly transferred.
// The previous move command toward the WorkPosition could not be executed
// because the product is being blocked by a workpiece.
// After the workpiece is removed, the direction flag is reset
// and the move command is restarted.

IF bReset = TRUE THEN
    iStep          := 10;
END_IF

CASE iStep OF

10:
    IF Diagnose = 16#307 THEN          // Move command could not be executed.
        iStep          := 20;        // Jump to the error step
                                   // to reset the direction flag
    END_IF

20:
    ControlWord      := 4;          // Reset the direction flags
                                   // (ResetDirectionFlag bit = TRUE in the ControlWord)
    iStep            := 30;        // Jump to the next step

30:
    IF NOT StatusWord.13 AND NOT      // Query whether both direction flags
    StatusWord.14 THEN                // (Bit ControlWord 0x0100 AND
                                   // ControlWord 0x0200 = FALSE in ControlWord)
        ControlWord      := 512;    // Moves back toward WorkPosition
        iStep            := 100;
    END_IF;

100:
    ;                                // Continue with the program

END_CASE
```

12.11 Recipe examples

12.11.1 Save recipe

The following example code shows how process parameters can be stored in the internal workpiece recipe.

```
// Store tool workpiece recipes in Structured Text (ST)

IF bStart = TRUE THEN
    iStep          := 10;
END_IF

CASE iStep OF

10:
    DeviceMode      := 100;    // Assignment of desired process parameters
    WorkpieceNo     := 3;      // Recipe is to be stored as the third workpiece recipe
    PositionTolerance := 50;
    GripForce       := 3;
    TeachPosition   := 500;
    iStep           := 20;    // Jump to the next step

20:
    ControlWord     := 1;      // Begins with the handshake
    iStep           := 30;    // Jump to the next step

30:
    IF StatusWord.12 THEN      // Queries the bit DataTransferOK=TRUE from StatusWord,
                                // Response of the product to transferred data
        ControlWord     := 0;    // Reset the ControlWord
        iStep           := 40;    // Jump to the next step
    END_IF;

40:
    IF NOT StatusWord.12 THEN  // Query for completion of the data transfer,
                                // DataTransferOK = FALSE
        ControlWord     := 2;    // Handshake is completed,
                                // storage starts here via the WritePDU bit in the ControlWord
        iStep           := 50;    // Jump to the next step
    END_IF;

50:
    IF StatusWord.12 THEN      // Queries the DataTransferOK = TRUE bit from StatusWord
        ControlWord     := 0;    // Reset the ControlWord
        iStep           := 60;    // Jump to the next step
    END_IF;

60:
    IF NOT StatusWord.12 THEN  // Query for completion of the data transfer,
                                // DataTransferOK = FALSE
        iStep           := 0;    // Storage is completed
    END_IF;

END_CASE
```

12.11.2 Loading a recipe

The following example code shows how process parameters can be loaded to the internal workpiece recipe.

```
// Load workpiece recipes in Structured Text (ST)
IF bLoad = TRUE THEN
    iStep          := 10;
END_IF

CASE iStep OF

10:
    WorkpieceNo    := 3;    // Load third workpiece recipe
    iStep          := 20;    // Jump to the next step

20:
    ControlWord    := 1;    // Begins with the handshake
    iStep          := 30;    // Jump to the next step

30:
    IF StatusWord.12 THEN          // Queries the bit DataTransferOK=TRUE from StatusWord,
                                    // Response of the product to transferred data
        ControlWord    := 0;    // Reset the ControlWord
        iStep          := 40;    // Jump to the next step
    END_IF;

40:
    IF NOT StatusWord.12 THEN      // Query for completion of the data transfer,
                                    // DataTransferOK = FALSE
        iStep          := 0;    //Handshake is completed,
                                    // Parameters from the third recipe have been taken over into the current process parameters.
    END_IF;
END_CASE
```

13 Operation

13.1 Operating Freedrive

INFORMATION



Freedrive is only available for installation size HRC-03-118505.

For manual soft-switching of the robot, the product is equipped with a Freedrive button ●.

The following work steps must be observed for manually teaching in the robot position:

- ▶ To soft-switch the robot, press the Freedrive button.
- ⇒ The robot can be moved manually.
- ⇒ The robot is moved with the product to the desired position.
- ▶ Release the Freedrive Button again as soon as you have reached the desired position.
- ⇒ The robot and product stop at their position.
 - ▶ Observe the information from the robot manufacturer for teaching in and activating the position of the robot and product in the control system.

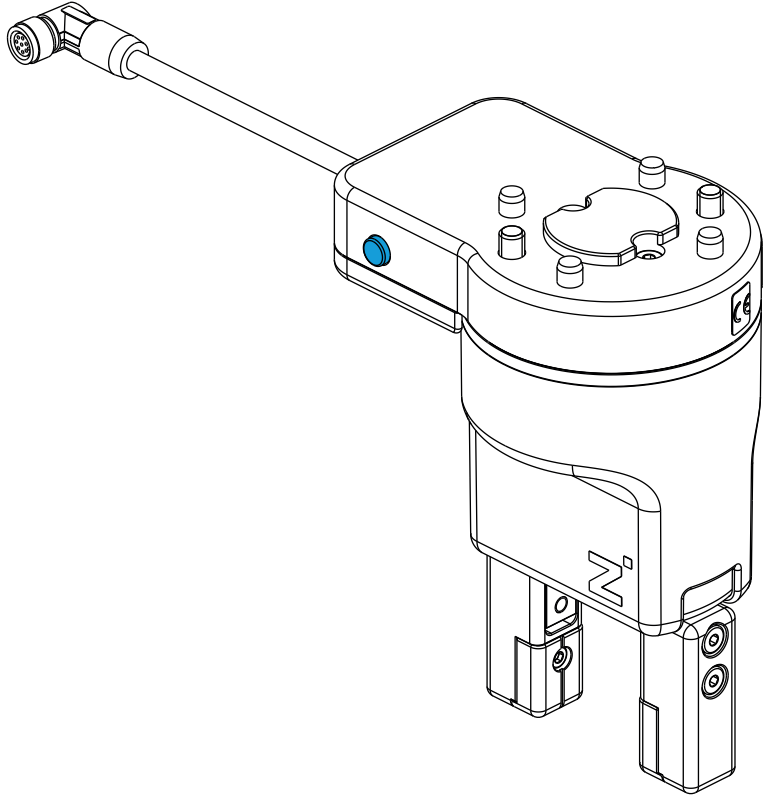

INFORMATION



- ▶ Details about activation can be found in the information from the robot manufacturer.

13.2 Setting the gripping force

NOTICE



In the event of a power failure, the gripper jaws remain in their positions and the gripping force of the product stays constant.

The gripper jaws can be opened using the emergency release if the energy supply drops off.

► Please contact Customer Service if you have any questions.

► Secure the workpieces to prevent them from falling.

The gripping force can be adjusted in four stages using a rotary switch.

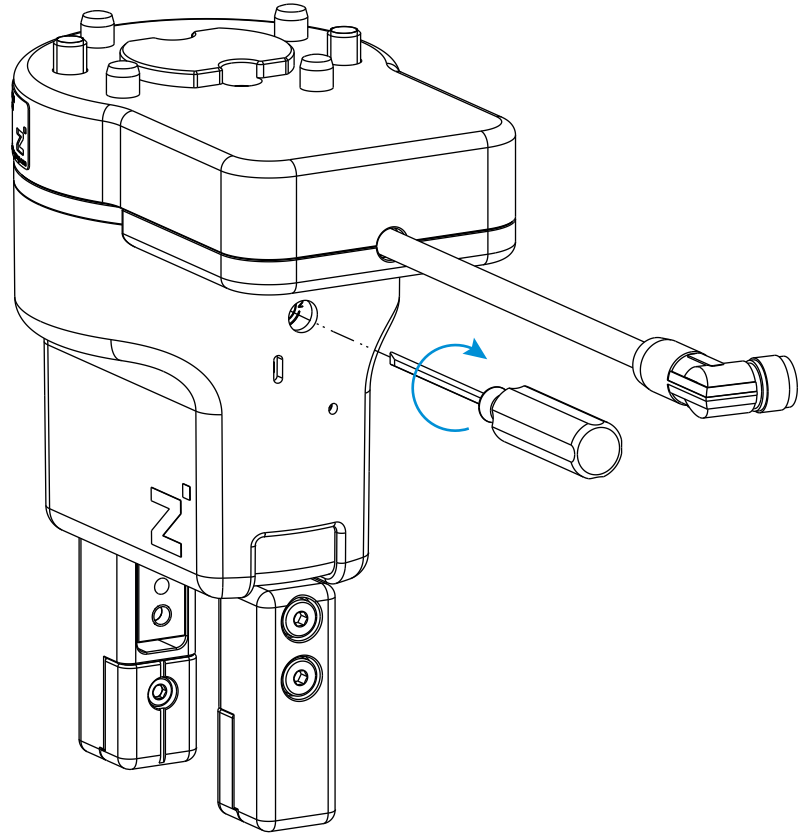

INFORMATION



The gripping force for installation size HRC-03-126902 can be set via the control system.

13.3 Emergency release

NOTICE



In the event of a power failure, the gripper jaws remain in their positions and the gripping force of the product stays constant.

The gripper jaws can be opened using the emergency release if the energy supply drops off.

► Please contact Customer Service if you have any questions.

The product features an emergency release that can be mechanically opened with an Allen key in the event of a power failure.

► Actuate the emergency release with a corresponding Allen key.

| Design size | Wrench size [mm] |
|-------------|------------------|
| HRC-03 | 1.5 |

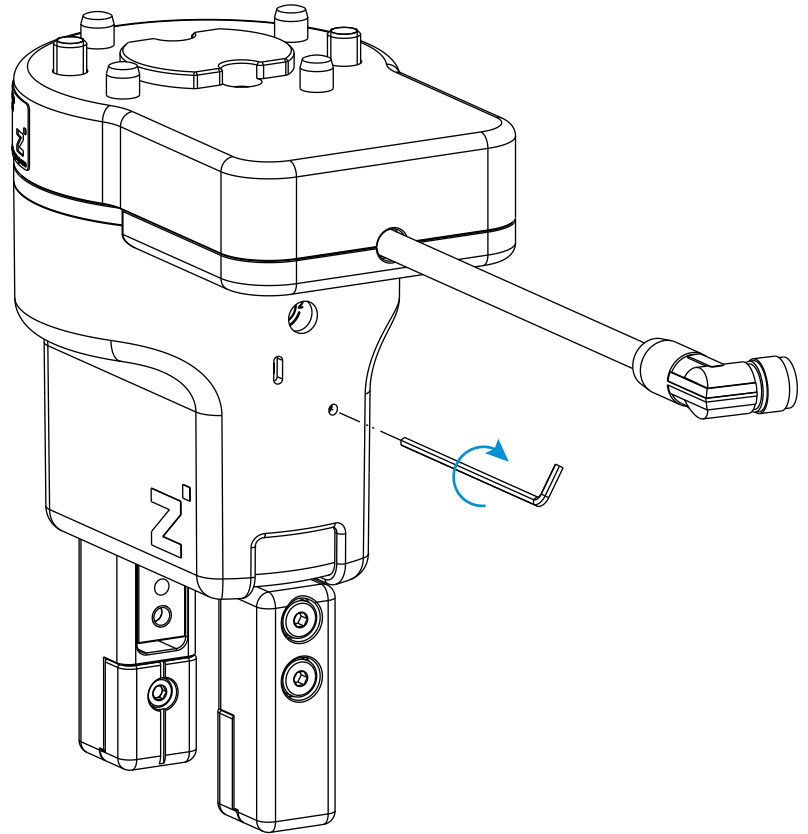

14 Gripping force charts

INFORMATION



► You can find information on our website.







► Please contact Customer Service if you have any questions.

15 Error diagnosis







| Error code | Error | Possible cause | Measure |
|------------|---|---|--|
| 0x0000 | Device is ready for operation. | - | - |
| 0x0002 | Position measuring system not referenced. | <ul style="list-style-type: none"> Product does not have any reference position. | <ul style="list-style-type: none"> ▶ Please contact Customer Service. |
| 0x0003 | Device is booted up. | <ul style="list-style-type: none"> The device is in the start sequence. | <ul style="list-style-type: none"> ▶ Wait until the start sequence is complete. |
| 0x0100 | Actuator power supply is not present or is too low | <ul style="list-style-type: none"> Actuator power supply is not connected Actuator power supply is not sufficient Cable break | <ul style="list-style-type: none"> ▶ Check the actuator power supply. |
| 0x0101 | Temperature above maximum permitted temperature. | <ul style="list-style-type: none"> Ambient temperature is too high. Overload of the products. | <ul style="list-style-type: none"> ▶ Provide sufficient ventilation/cooling/connection. ▶ Check that the product moves freely. |
| 0x0102 | Temperature is below minimum permitted temperature. | <ul style="list-style-type: none"> Ambient temperature is too low. | <ul style="list-style-type: none"> ▶ Provide an adequate operating temperature. |
| 0x0103 | Temperature of the power level is too high | <ul style="list-style-type: none"> Surrounding temperature is too high Overload of the product Internal defect | <ul style="list-style-type: none"> ▶ Ensure improved cooling of the product. ▶ Check that the product moves freely. ▶ Increase the break time between the gripping movements. |
| 0x010B | Workpiece lost | <ul style="list-style-type: none"> Gripping force is not sufficient Workpiece was not gripped correctly Gripper finger geometry does not match the gripped workpiece Workpiece is too heavy | <ul style="list-style-type: none"> ▶ Check the required gripping force. ▶ Check the gripper finger geometry. ▶ Reset the error by sending another move command back. |
| 0x0300 | ControlWord is not plausible. | <ul style="list-style-type: none"> Multiple bits were set in the ControlWord. | <ul style="list-style-type: none"> ▶ In the ControlWord, check that only one bit is set. |
| 0x0301 | Position implausible | <ul style="list-style-type: none"> Transmitted TeachPosition is not plausible. | <ul style="list-style-type: none"> ▶ Check the transmitted process data. |
| 0x0302 | GripForce is not plausible. | <ul style="list-style-type: none"> Transmitted GripForce is not plausible. | <ul style="list-style-type: none"> ▶ Check the transmitted process data. |
| 0x0304 | PositionTolerance is not plausible. | <ul style="list-style-type: none"> Transmitted PositionTolerance is not plausible. | <ul style="list-style-type: none"> ▶ Check the transmitted process data. |
| 0x0305 | Erroneous reference position | <ul style="list-style-type: none"> Product does not have any reference position. | <ul style="list-style-type: none"> ▶ Please contact Customer Service. |
| 0x0306 | DeviceMode is not plausible. | <ul style="list-style-type: none"> Transmitted DeviceMode is not plausible. | <ul style="list-style-type: none"> ▶ Check the transmitted process data. |
| 0x0307 | Motion task cannot be executed (CRC error). | <ul style="list-style-type: none"> Multiple motion tasks in the same direction. Move command transmitted despite existing error. | <ul style="list-style-type: none"> ▶ Reset the direction flag. <ul style="list-style-type: none"> • through move command in the opposite direction • through error reset • through reset direction flag ▶ Send the move command again. |

| Error code | Error | Possible cause | Measure |
|------------|--|--|--|
| 0x0308 | WorkpieceNo cannot be selected. | <ul style="list-style-type: none"> Transmitted workpiece number is outside the permitted range. | <ul style="list-style-type: none"> ▶ Check the transmitted process data. ▶ Apply the process data via a handshake. |
| 0x0309 | TeachPosition was changed. | <ul style="list-style-type: none"> Modified process data were not taken over. | <ul style="list-style-type: none"> ▶ Apply the process data via a handshake. |
| 0x030D | GripForce was changed. | <ul style="list-style-type: none"> Modified process data were not taken over. | <ul style="list-style-type: none"> ▶ Apply the process data via a handshake. |
| 0x030F | TeachTolerance was changed. | <ul style="list-style-type: none"> Modified process data were not taken over. | <ul style="list-style-type: none"> ▶ Apply the process data via a handshake. |
| 0x0310 | DeviceMode was changed. | <ul style="list-style-type: none"> Modified process data were not taken over. | <ul style="list-style-type: none"> ▶ Apply the process data via a handshake. |
| 0x0311 | WorkpieceNo was changed. | <ul style="list-style-type: none"> Modified process data were not taken over. | <ul style="list-style-type: none"> ▶ Apply the process data via a handshake. |
| 0x0312 | Initial state after gripper restart | <ul style="list-style-type: none"> Modified process data were not taken over. | <ul style="list-style-type: none"> ▶ Apply the process data via a handshake. |
| 0x0400 | Difficulty of movement | <ul style="list-style-type: none"> Insufficient power supply. Gripper jaws are blocked. Gripper jaws are difficult to move. | <ul style="list-style-type: none"> ▶ Check the power supply. ▶ Check that the product moves freely. |
| 0x0406 | System error | <ul style="list-style-type: none"> Internal system error | <ul style="list-style-type: none"> ▶ Please contact Customer Service. |
| 0x040B | Internal error | <ul style="list-style-type: none"> Internal error | <ul style="list-style-type: none"> ▶ Please contact Customer Service. |
| 0x0411 | No production parameters present on the product. | <ul style="list-style-type: none"> Internal error | <ul style="list-style-type: none"> ▶ Please contact Customer Service. |

15.1 Status in LED display for IO-Link error

| | | |
|---|--|---|
|  | Green LED lights up continuously. | <ul style="list-style-type: none"> No error |
|  | Red LED flashes every second. Green LED lights up continuously. | <ul style="list-style-type: none"> No IO-Link communication |
|  | Red LED lights up continuously. | <ul style="list-style-type: none"> Actuator supply not OK |
|  | Red LED flashes every second. Green LED does not light up. | <ul style="list-style-type: none"> Process data are invalid. Internal error |
|  | Red LED flashes every second. Green LED flashes every second (at the same time). | <ul style="list-style-type: none"> No reference position A reference run must be performed. |
|  | Red LED flashes every second. Green LED flashes every second (alternating). | <ul style="list-style-type: none"> A reference run is being performed. |

15.2 Status in LED display for Digital error

| | | |
|---|--|---|
|  | Green LED lights up continuously. | <ul style="list-style-type: none"> No error |
|  | Red LED flashes every second. Green LED lights up continuously. | <ul style="list-style-type: none"> Loss of workpiece detected. |
|  | Red LED lights up continuously. | <ul style="list-style-type: none"> Actuator supply not OK |
|  | Red LED flashes every second. Green LED does not light up. | <ul style="list-style-type: none"> Internal error |
|  | Red LED flashes every second. Green LED flashes every second (at the same time). | <ul style="list-style-type: none"> No reference position A reference run must be performed. |
|  | Red LED flashes every second. Green LED flashes every second (alternating). | <ul style="list-style-type: none"> A reference run is being performed. |

16 Table with acyclic data (ISDU)

INFORMATION



IO-Link distinguishes between cyclical process data (PDU) and acyclic data (ISDU).

Access to acyclic data is not arranged very conveniently for all control system and IO-Link master combinations. For this reason, the product can be used without acyclic data. This makes it as easy as possible to control the product.

► Please contact Customer Service if you have any questions.

INFORMATION



► Note that the acyclic data with the following parameters correspond to the reflection of the process data:

- StatusWord, Diagnosis, ControlWord, ActualPosition, TeachPosition, WorkpieceNo, DeviceMode, PositionTolerance, GripForce, DriveVelocity, BasePosition, ShiftPosition, WorkPosition

| Index | Name | Data format | Access rights | Values | Description |
|--------------|-------------------|-------------|---------------|---|--|
| 0x0017 (23) | Firmware version | STRING | Read | - | Firmware version <ul style="list-style-type: none"> • Example: SWA000170_A00 • Type: SWA000170 • Version: A00 |
| 0x0040 (64) | StatusWord | UINT16 | Read | 0 - 65535 | Parameter to read out the StatusWord. |
| 0x0041 (65) | Diagnosis | UINT16 | Read | 0 - 65535 | Read out of the diagnostic code. |
| 0x0042 (66) | Cycle counter | UINT32 | Read | 0 to 4294967295 | Read out of the total number of cycles. |
| 0x0043 (67) | Temperature | UINT16 | Read | 0 to 100 °C | Current temperature |
| 0x0044 (68) | ControlWord | UINT16 | Read | 0 - 65535 | Read out the current temperature. |
| 0x0045 (69) | Error code | STRING | Read | 1 to 32 | Read out of the current error state. |
| 0x0046 (70) | Error counter | UINT32 | Read | 0 to 4294967295 | Read out of the number of errors since the restart. |
| 0x0100 (256) | ActualPosition | UINT16 | Read | 0 to max. jaw stroke of the product [0,01 mm] | Read out of the current position of the gripper jaws relative to the full stroke. |
| 0x0101 (257) | TeachPosition | UINT16 | Read | 0 to max. jaw stroke of the product [0,01 mm] | Read out of the current transmitted TeachPosition. |
| 0x0102 (258) | WorkpieceNo | UINT8 | Read | 0 - 32 | Read out of the transmitted workpiece number. |
| 0x0103 (259) | DeviceMode | UINT8 | Read | 1-103 | Read out of the transmitted travel mode. |
| 0x0104 (260) | PositionTolerance | UINT8 | Read | 0 to 255 | Read out of the transmitted tolerance of the TeachPosition. |
| 0x0105 (261) | GripForce | UINT8 | Read | 1 to 130 % | Read out of the transmitted gripping force. |
| 0x0107 (263) | DriveVelocity | UINT8 | Read | 1 to 100 % | Read out of the transmitted movement speed. |

| Index | Name | Data format | Access rights | Values | Description |
|---------------------------------|---|-------------|---------------|-------------------------------------|--|
| 0x0108 (264) | BasePosition | UINT16 | Read | 0 to max. jaw stroke of the product | Read out of the transmitted outer jaw position. |
| 0x0109 (265) | ShiftPosition | UINT16 | Read | 0 to max. jaw stroke of the product | Read out of the transmitted toggle position. |
| 0x010A (266) | WorkPosition | UINT16 | Read | 0 to max. jaw stroke of the product | Read out of the transmitted inner jaw position. |
| 0x0114 (276) Subindex 1 to 4 | WorkPosition/ BasePosition tolerance window | UINT16 | Read/write | 0 - 65535 | <ul style="list-style-type: none"> ▶ Setting the BasePosition and WorkPosition tolerance window <ul style="list-style-type: none"> • Subindex 0: Read/write • Subindex 1: from BasePosition to the outside • Subindex 2: from BasePosition to the inside • Subindex 3: from WorkPosition to the inside • Subindex 4: from WorkPosition to the outside ▶ Resetting all changes to factory settings using an IO-Link factory reset |
| 0x022F (559) | Holding current | UINT16 | Read/write | 0 to 1000 | Amperage [%] for current after-supply scaled to the maximum permitted current. |
| 0x0230 (560) | Holding time | UINT16 | Read/write | 0 to 1000 | Time duration [ms] for current after-supply |
| 0x0232 (562) | Emergency Mode | UINT16 | Read/write | 0 to 1 | <ul style="list-style-type: none"> ▶ Deactivation of message 0x0400 by ISDU: <ul style="list-style-type: none"> • Index = 562 (decimal) • Subindex = 0 • Value = 0 ▶ Activation of message 0x0400 by ISDU: <ul style="list-style-type: none"> • Index = 562 (decimal) • Subindex = 0 • Value = 1 |

17 Maintenance

NOTICE



Material damage resulting from blowing out with compressed air

Blowing out the product with compressed air can cause malfunctions and pose a risk of accidents.

- ▶ Never purge the product with compressed air.

NOTICE



Material damage caused by unsuitable cleaning materials

Liquid and solvent-based cleaning agents can cause malfunctions and pose a risk of accidents.

- ▶ Do not clean the product with any cleaning agents that are liquid or contain solvents.

NOTICE



Material damage due to leaking lubricant

Excessive lubrication can cause moving machine parts to leak lubricant. This can cause soiling of the machine, the workpiece and the environment.

- ▶ Only use approved or recommended lubricants.
- ▶ Observe the manufacturer information for use of specific lubricants.
- ▶ Adhere to the lubrication interval.
- ▶ Avoid excessive lubrication.
- ▶ Remove leaking lubricant immediately and thoroughly.
- ▶ Replace damaged seals.

Maintenance-free operation of the product is guaranteed for up to 10 million cycles.

- ▶ Note that the product could become damaged under the following circumstances:

- Dirty environment
- Improper use and use that does not comply with the performance data
- Permissible temperature range not observed

- ▶ Even though the product is maintenance-free as mentioned above, perform a regular visual inspection to check for any damage or contamination.
- ▶ Have maintenance work that requires disassembly of the product performed by customer service if possible.

⇒ Dismantling and reassembling the product without authorization may result in complications, as special installation equipment is required in some cases. Zimmer GmbH accepts no liability for any resulting malfunctions or damage.

18 Decommissioning/disposal

INFORMATION



When the product reaches the end of its operational phase, it can be completely disassembled and disposed of.

- ▶ Disconnect the product completely from the power supply.
- ▶ Dispose of the components properly according to the material groups.
- ▶ Comply with the locally applicable environmental and disposal regulations.

19 RoHS declaration

in terms of the EU Regulation 2011/65/EU

Name and address of the manufacturer:

Zimmer GmbH

- 📍 Im Salmenkopf
77866 Rheinau, Germany
- ☎ +49 7844 9138 0
- ✉ info@zimmer-group.com
- 🌐 www.zimmer-group.com

We hereby declare that the incomplete machine described below

- Product designation:** 2-jaw parallel gripper, electric
- Type designation:** HRC-03

conforms to the requirements of the directive in its design and the version we put on the market.

| | | |
|---|------------------------------|--|
| Michael Hoch | Rheinau, Germany, 2019-09-02 |  |
| Authorized representative for the compilation of relevant technical documents | (Place and date of issuance) | Martin Zimmer (Legally binding signature) Managing Partner |

20 REACH declaration

In terms of the EC Regulation 1907/2006

Name and address of the manufacturer:

Zimmer GmbH

- 📍 Im Salmenkopf
77866 Rheinau, Germany
- ☎ +49 7844 9138 0
- ✉ info@zimmer-group.com
- 🌐 www.zimmer-group.com

REACH stands for **R**egistration, **E**valuation, **A**uthorisation and **R**estriction of **C**hemicals.

A full declaration of REACH can be obtained from the manufacturer due to the duty to notify in accordance with Art. 33 of the REACH regulation (“Duty to communicate information on substances in articles”).

| | | |
|---|------------------------------|--|
| Michael Hoch | Rheinau, Germany, 2019-09-02 |  |
| Authorized representative for the compilation of relevant technical documents | (Place and date of issuance) | Martin Zimmer (Legally binding signature) Managing Partner |

21 Declaration of Incorporation

In terms of the EU Machinery Directive 2006/42/EC (Annex II 1 B)

Name and address of the manufacturer:

Zimmer GmbH

Im Salmenkopf
77866 Rheinau, Germany
+49 7844 9138 0
info@zimmer-group.com
www.zimmer-group.com

We hereby declare that the incomplete machine described below

Product designation: 2-jaw parallel gripper, electric

Type designation: HRC-03

conform to the requirements of the Machinery Directive, 2006/42/EC, Article 2g, Annex VII.b – Annex II.b, in its design and the version we put on the market.

Basic health and safety requirements:

No. 1.1.2, No. 1.1.3, No. 1.1.5, No. 1.3.2, No. 1.3.4, No. 1.3.7, No. 1.3.9, No. 1.5.1, No. 1.5.2, No. 1.5.4, No. 1.6.4, No. 1.7.1, No. 1.7.4

A full list of applied standards can be obtained from the manufacturer.

We also declare that the specific technical documents were produced in accordance with Annex VII Part B of this Directive. We undertake to provide the market supervisory bodies with electronic versions of special documents for the incomplete machine through our documentation department, should they have reason to request them.

The incomplete machine may only be commissioned if it has been ascertained, if applicable, that the machine or system in which the incomplete machine is to be installed satisfies the requirements of Directive 2006/42/EC on Machinery and an EC Declaration of Conformity has been drawn up in accordance with Annex II 1 A.

Kurt Ross

Authorized representative for the compilation of relevant technical documents

Rheinau, Germany, 2019-09-02

(Place and date of issuance)

Martin Zimmer
(Legally binding signature)
Managing Partner

22 Declaration of Conformity

As defined by the EC Directive 2014/30/EU on electromagnetic compatibility

Name and address of the manufacturer:

Zimmer GmbH

- 📍 Im Salmenkopf
77866 Rheinau, Germany
- ☎ +49 7844 9138 0
- ✉ info@zimmer-group.com
- 🌐 www.zimmer-group.com

We hereby declare that the products described below

- Product designation:** 2-jaw parallel gripper, electric
- Type designation:** HRC-03

conforms to the requirements of the 2006/42/EC directive in its design and the version we put on the market.

The following harmonized standards have been used:

- DIN EN ISO 12100 Safety of machinery - General principles for design - Risk assessment and risk reduction
- DIN EN 61000-6-3 EMC Generic standard, Emission standard for residential, commercial and light-industrial
- DIN EN 61000-6-2 EMC Generic standard, Emission standard for industrial environments
- DIN EN 61000-6-4 EMC Generic standard, Immunity for industrial environments

A full list of applied standards can be obtained from the manufacturer.

Kurt Ross
Authorized representative for the compilation of relevant technical documents

Rheinau, Germany, 2019-09-02
(Place and date of issuance)



Martin Zimmer
(Legally binding signature)
Managing Partner