

Installation and Operation Instructions
GG1000
 DDOC00272 Index a
 Im Salmenkopf 5
 D-77866 Rheinau
 ☎: +49(0)7844 9138-0
 ☎: +49(0)7844 9138 80
 www.zimmer-group.com

1. Supporting documents



NOTE:
 The following documents are available for download on our website. Only the documents currently available on the website are valid.

- Catalog
- Drawings, performance data, information about accessory parts, etc.
- Technical data (data sheets)
- General terms and conditions, including warranty information

2. Proper use



NOTE:
 The GG1000 series gripper is only to be used in its original state with its original accessories, with no unauthorized changes and within the scope of its defined parameters for use. Zimmer GmbH shall accept no liability for any damage caused by improper use.

The gripper is designed for operation with compressed air only. It is not suited for operation with other media such as liquids or gases. The gripper is used as defined under "Proper use" in enclosed rooms for time-restricted gripping, handling and holding workpieces. It is not suitable for clamping workpieces during a machining process or for direct contact with perishable goods.



Proper use of the gripper also includes the forces and torques that may be acting in addition to the gripping force. (See product data sheets at www.zimmer-group.com)

3. Personnel qualifications

Installation, commissioning and maintenance may only be performed by qualified personnel. These persons must have read and understood the installation instructions in full.

4. Safety notes

1. Installation, commissioning, maintenance and repairs may only be performed by qualified experts in accordance with these installation and operating instructions.
2. The gripper is state-of-the-art. It is fitted to industrial machines and is used to hold workpieces. The following are examples of situations in which the gripper may cause a hazard if the gripper is not properly fitted, used or maintained:
 - the gripper is not used for its intended purpose
 - failure to observe the local regulations (legislation, guidelines, directives), such as the EC Machinery Directive,
 - the Accident Prevention Regulations and the assembly and operating instructions
 - The gripper may be used only in accordance with its proper use and technical data ZIMMER GmbH shall accept no liability for any damage caused by improper use.
3. Any use other than the proper use requires written approval from Zimmer GmbH
4. Do not reach into the operating range of the gripper.
5. Make sure that the energy supply is disconnected and before you install, retool, maintain or repair the gripper.
6. In case of maintenance, renovation or expansion work, remove the gripper from the machine and carry out the work outside the danger zone.
7. When commissioning or testing, make sure that the gripper cannot be actuated by mistake.
8. Modifications to the gripper, such as adding drill holes or threads, may be made only with prior approval from Zimmer GmbH.
9. The specified maintenance intervals and compressed air quality specifications are to be observed; also refer to the Maintenance section. Please contact our hotline for this purpose.
10. Use of the gripper under extreme conditions, such as aggressive liquids and abrasive dust, is subject to prior approval from Zimmer GmbH
11. When disassembling grippers with integrated springs, exercise increased caution because spring tension is always present.
12. When disassembling grippers with integrated springs, exercise increased caution because spring tension is always present.

5. Function

The function relies on the action of a pneumatic piston vented on both sides. Alternating ventilation moves the pneumatic piston up and down. The energy generated in this process is transferred to the gripper jaws by a kinematic system, producing the gripping force. The spring used in the cylinder chamber in the GG1000 designs acts as an energy accumulator and gripping force safety device.

①	Cam-switch an mounting block For position sensing
②	Robust, lightweight housing Hard-coated aluminum alloy
③	Sensing slot Groove for positioning of the magnetic field sensor
④	Permanent magnet Sensing of the position setting position via magnetic field sensor
⑤	Positively driven lever mechanism Synchronized the movement of the gripper jaws
⑥	Integrated gripping force safety device Spring integrated into cylinder as energy storage
⑦	Drive Double-acting pneumatic cylinder
⑧	Removable centering sleeves Quick and economical positioning of the gripper fingers

Fig. 1: GG1000 gripper

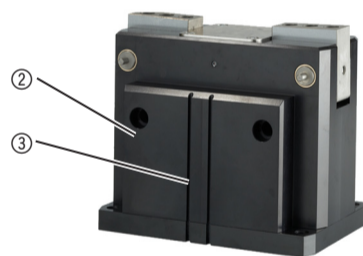
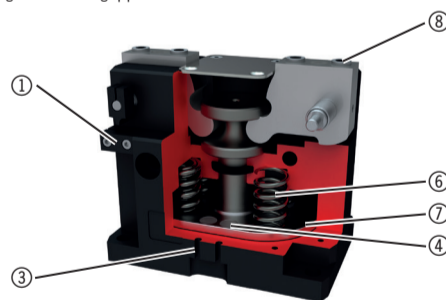

Fig. 2: GG1000 gripper cross-section



6. Installation



WARNING:
 Risk of injury in case of unexpected movement of the machine or system into which the gripper is being installed.

- ▶ Switch off the energy supply to the machine before all work
- ▶ Secure the machine against being switched on unintentionally
- ▶ Check the machine for any residual energy



CAUTION:
 Risk of injury in case of unexpected movement of the gripper when pneumatic energy is connected.

- ▶ Switch off the pneumatic energy before all work
- ▶ Secure the pneumatic circuit against being switched on unintentionally
- ▶ Check the pneumatic circuit for any existing residual energy; bleed if necessary

6.1 Installing the gripper

The gripper can be fitted on a mounting surface from several sides with the necessary evenness.

Length of the mounting surface [mm]	Permitted unevenness [mm]
<100	<0,02
>100	<0,05

Two alternative options are available for the installation of the gripper:

Mounting position	Connection
Housing floor	⑩
Laterally through the housing	⑪
Straight pins in the bore holes	⑬

The dimensional drawing for the GG1000 is shown as an example in the adjacent image. The dimensional drawings can be found on our website.

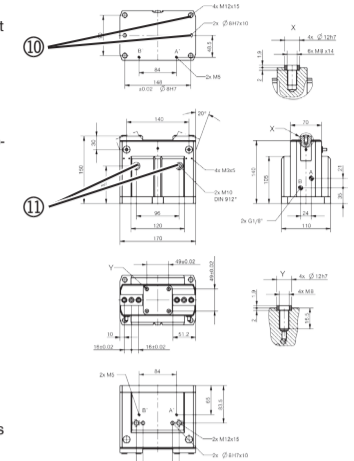

The dimensions for the design of the mounting piece can be found on the respective data sheet on our website. You can download any necessary CAD data in all common formats from our website:

www.zimmer-group.com

Make the following selections:
 Handling technology/gripper/pneumatic/2-jaw parallel grippers/GG1000 series

Depending on the size, mounting screws from M3 to M16 and of strength class 8.8 are used. The following tightening must be observed upon installation:

Screw size	M3	M4	M5	M6	M8	M10	M12	M14	M16
Permitted tightening torque [Nm]	1,3	2,9	6,0	10,2	24,9	49,5	86,3	138,0	214,9

6.2 Accessory installation

Depending on the design size, the pneumatic connections ② are located on a side surface of the housing or, alternatively, on the bottom surface or rear side of the housing ②.

Connection A ②	Closes the gripper
Connection B ②	Opens the gripper
Connection A' (alternative) ②	Closes the gripper
Connection B' (alternative) ②	Opens the gripper

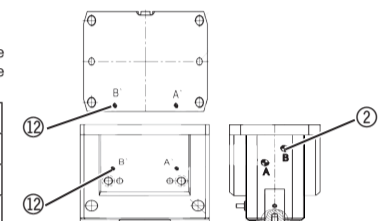

NOTE:
 Close off unused pneumatic connections with dummy plugs.

For the available pneumatic connections, refer to the accessories list on the product data sheets on our website. You can also find the necessary ordering information there.

6.3 Gripper finger and sensor installation



NOTE:
 Before installing the gripper fingers, check that they are of a suitable length for the selected gripper variant.

The available accessory is shown on the product data sheets on our website. You can also find the necessary ordering information there.

- Fasten the gripper jaws ⑫ using centering sleeves ⑬ and cylinder screws of strength class 8.8 on the designated positions ⑪.
- Install threaded pneumatic connections ⑬ into the provided connections.

Inductive proximity switch:

- Install the mounting block ⑭ on the gripper.
- Insert the inductive proximity switch ⑰ into the mounting block ⑭ and tension it.

Magnetic field sensor:

- Insert, position the magnetic field sensors ⑮ into the designated slots ⑬ and clamp them in.

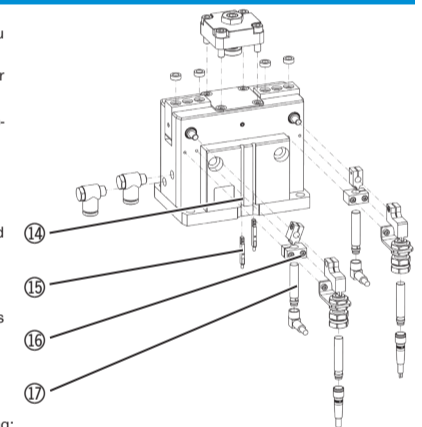

7. Technical data

These multi-page data sheets (see example image to the right) contain the following:

- a product description
- the technical data
- a dimensional drawing
- the available accessories



INFORMATION:
 Please gather the technical data from our website www.zimmer-group.com. This data varies within the series depending on the specific design. If you should have further questions on products or on technical data, please contact ZIMMER GmbH customer service.

7.1 Product designation:

Type designation	GG 1 □ □ □ □
Series	
Functional principle F NC (gripper finger, normally close), external gripping	
Functional principle NC (normally close), external gripping	

8. Maintenance

Maintenance-free operation of the gripper is guaranteed for up to **10 million** gripping cycles.

The maintenance interval may shorten under the following circumstances:

- Operation with compressed air that does not comply with DIN ISO 8573-1 quality class 4
- Dirty environment
- Improper use and use that does not comply with the performance data
- Ambient temperature of more than 60°C; lubricants harden faster!

We recommend using the Zimmer GmbH repair service for maintenance and the replacement of seals.

Dismantling and reassembling the gripper without authorization may result in complications, as special installation equipment is required in some cases.

9. Declaration of incorporation

In terms of the EU Machinery Directive 2006/42/EC (Annex II 1 B)

Name and address of the manufacturer:

ZIMMER GmbH • Im Salmenkopf 5 • D-77866 Rheinau, Germany • Phone: +49 7844 9138 0 • Fax: +49 7844 9138 80
www.zimmer-group.de

We hereby declare that the incomplete machine described below

Product designation: Pneumatic gripper
Type designation: GG1 □ □ □ □

satisfies the following basic requirements of the Machinery Directive 2006/42/EC

No. 1.1.2., No. 1.1.3., No. 1.1.5., No. 1.3.2., No. 1.3.4., No. 1.3.7., No. 1.5.3., No. 1.5.4., No. 1.5.8., No. 1.6.4., No. 1.7.1., No. 1.7.4.

We also declare that the specific technical documents were produced in accordance with Annex VII Part B of this Directive.

We undertake to provide the market supervisory bodies with electronic versions of special documents for the incomplete machine through our documentation department, should they have reason to request them.

The incomplete machine may only be commissioned if the machine or system in which the incomplete machine is to be installed has been determined to satisfy the conditions of the Machinery Directive 2006/42/EC and the EC Declaration of Conformity has been produced in accordance with Annex II 1 A.

Authorized representative for compiling the relevant technical documents

Kurt Ross	See manufacturer's address	Rheinau, 04.05.2015	Martin Zimmer, Managing Director
First name, last name	Address	(Place and date of issuance)	(Legally binding signature)