



INSTALLATION AND OPERATING INSTRUCTIONS

Pneumatic tool changer

WWR1000

DDOC00291

THE KNOW-HOW FACTORY

Content

- 1 Supporting documents 3
 - 1.1 Notices and graphics in the installation and operating instructions 3
- 2 Safety notices 4
- 3 Proper use 5
- 4 Personnel qualification 5
 - 4.1 Electricians 5
 - 4.2 Specialists 5
 - 4.3 Instructed personnel..... 5
 - 4.4 Service personnel..... 5
 - 4.5 Additional qualifications 5
- 5 Product description 6
 - 5.1 Type plate 6
 - 5.2 Product variants and compatibility 6
- 6 Functional description 7
 - 6.1 Functional safety 7
- 7 Technical data 8
- 8 Accessories/scope of delivery 8
- 9 Transportation/storage/preservation 8
- 10 Installation 9
 - 10.1 Installing the stationary part..... 9
 - 10.2 Installing the loose part 10
 - 10.3 Installing the energy supply 10
 - 10.3.1 Pneumatic control 11
 - 10.4 Mounting the inductive sensors 13
 - 10.4.1 Sensing the piston position 13
 - 10.4.2 Sensing a loose part..... 13
 - 10.5 Installing the storage station 14
- 11 Operation 16
 - 11.1 Emergency release 16
- 12 Maintenance 18
- 13 Decommissioning/disposal 18
- 14 Declaration of Incorporation 19
- 15 REACH declaration 20

1 Supporting documents

NOTICE



Read through the installation and operating instructions before installing or working with the product.

The installation and operating instructions contain important notes for your personal safety. They must be read and understood by all persons who work with or handle the product during any phase of the product lifetime.



The documents listed below are available for download on our website www.zimmer-group.com.

- Installation and operating instructions
 - Catalogs, drawings, CAD data, performance data
 - Information on accessories
 - Technical data sheets
 - General Terms and Conditions, including warranty information.
- ⇒ Only those documents currently available on the website are valid.

In these installation and operating instructions, "product" refers to the product designation on the title page!

1.1 Notices and graphics in the installation and operating instructions

DANGER



This notice warns of an imminent danger to the life and health of people. Ignoring these notices can lead to serious injury or even death.

- ▶ You absolutely must comply with the described measures for avoiding these dangers!
- ⇒ The warning symbols are assigned according to the type of danger.

WARNING



This notice warns of a situation that is potentially hazardous to personal health. Ignoring these notices can cause serious injury or damage to health.

- ▶ You absolutely must comply with the described measures for avoiding these dangers!
- ⇒ The warning symbols are assigned according to the type of danger.

CAUTION



This notice warns of a situation that is potentially hazardous to persons. Ignoring these notices can cause minor, reversible injuries.

- ▶ You absolutely must comply with the described measures for avoiding these dangers!
- ⇒ The warning symbols are assigned according to the type of danger.

NOTICE



This notice warns of possible material and environmental damage. Ignoring these notices can result in damage to the product or the environment.

- ▶ You absolutely must comply with the described measures for avoiding these dangers!
- ⇒ The warning symbols are assigned according to the type of danger.

INFORMATION



This category contains useful tips for handling the product efficiently. Failure to observe these tips will not result in damage to the product. This information does not include any information relevant to health or workplace safety.

2 Safety notices

CAUTION



Risk of injury and material damage in case of non-compliance

Installation, commissioning, maintenance and repairs may only be performed by qualified specialists in accordance with these installation and operating instructions.

The product is state-of-the-art.

The following are examples of situations in which the product may cause a hazard:

- The product is not properly installed, used or maintained.
- The product is not used for its designated purpose.
- The locally applicable regulations, laws, directives or guidelines are not observed.
- ▶ The product may only be used in accordance with these installation and operating instructions and the product's technical data. Any changes or additions to the intended use of the product, as well as modifications to the product, such as those in the following examples, require the written permission of the manufacturer:
 - Use of the product under extreme conditions, such as aggressive fluids or abrasive dusts
 - Additional drilled holes or threads
- ⇒ Zimmer GmbH shall accept no liability for any damage caused by improper use. The operator bears sole responsibility.
- ▶ Make sure that the power supply is disconnected before you mount, adjust, modify, maintain or repair the product.
- ▶ Whenever work is carried out on the product, make sure that the product cannot be actuated by mistake.
- ▶ Perform maintenance tasks, renovation work or attachment work outside of the machine's danger zone when possible.
- ▶ Do not reach into the operational range of the product.
- ▶ Observe the specified maintenance intervals and specifications regarding the quality of the operating material.
- ▶ When using the product under extreme conditions, adjust the maintenance interval according to the degree of contamination.
- ▶ Check the completeness and tightening torques of all mounting screws.

3 Proper use

NOTICE



Material damage and malfunction in case of non-compliance

The product is only to be used in its original state with its original accessories, with no unauthorized changes and within the stipulated parameter limits and operating conditions.

Any other or secondary use is deemed improper.

- ▶ Operate the product only in compliance with the associated installation and operating instructions.
 - ▶ Operate the product only when it is in a technical condition that corresponds to the guaranteed parameters and operating conditions.
- ⇒ Zimmer GmbH shall accept no liability for any damage caused by improper use. The operator bears sole responsibility.

- The product is designed exclusively for pneumatic operation.
- The product is intended for industrial use.
- The product is designated for use in closed facilities.
- Direct contact with perishable goods/food is not permitted.

4 Personnel qualification

WARNING



Injuries and material damage due to inadequate qualification

If inadequately qualified personnel perform work on the product, this can cause serious injuries and significant material damage.

- ▶ All work on the product must be performed by qualified personnel.
- ▶ Before working with the product, read the document in its entirety and make sure that you have understood everything.
- ▶ Observe country-specific accident prevention regulations and the general safety notices.

The following qualifications are a prerequisite for performing various work on the product.

4.1 Electricians

Electricians are able to perform work on electrical systems, can recognize and avoid possible dangers and know the relevant standards and provisions due to their technical training, knowledge and experience.

4.2 Specialists

Specialists are able to perform the assigned work, can recognize and avoid possible dangers and know the relevant standards and provisions due to their technical training, knowledge and experience.

4.3 Instructed personnel

Instructed personnel have been trained by the operating company on the tasks and possible dangers of improper behavior.

4.4 Service personnel

Service personnel are able to perform the assigned work and can recognize and avoid possible dangers due to their technical training, knowledge and experience.

4.5 Additional qualifications

Persons who work with the product must be familiar with the valid safety regulations and laws as well as the standards, guidelines and laws listed in this document.

Personnel who work with the product must have facility-issued authorization to commission, program, configure, operate, maintain and also decommission this product.

5 Product description

The product is a pneumatically operated exchange system.

It consists of a loose part and a stationary part. A storage station is available as an option.

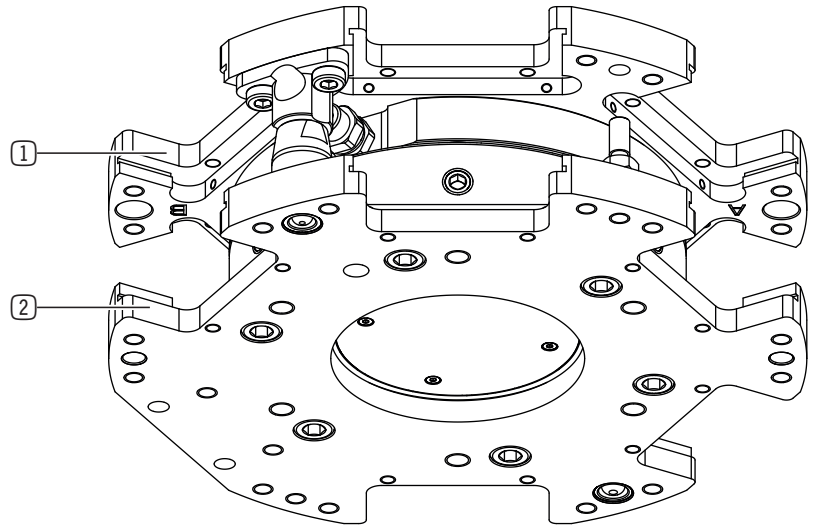

- ① Stationary part (WWR1xxxF)
- ② Loose part (WWR1xxxL)

5.1 Type plate

A type plate is attached to the product.

The article number and the confirmation number are shown on the type plate.

- ① Article number
- ② Confirmation number

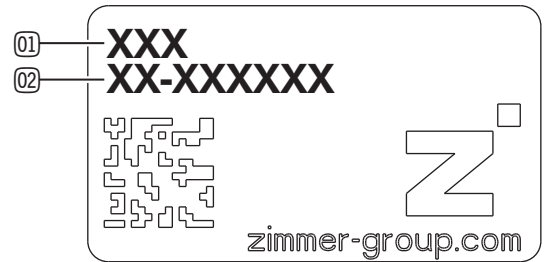

5.2 Product variants and compatibility

INFORMATION



Depending on the installation size of the product, several transmission elements are available for the actuator power supply.

Optionally, the media transmission can be set up with transmission elements at corresponding interfaces on the tool changer.

- ▶ Please contact Customer Service if you have any questions.

6 Functional description

The stationary part is installed on a robot system. It is used to hold a loose part.

Several storage stations can be used to hold differently equipped loose parts for operation with a stationary part.

The locking bolts in the locking sleeve enable a friction-locked connection of the stationary and loose part.

The stroke is generated by a double-acting pneumatic rotor cylinder. An integrated spring acts as an energy store and preserves the capability of product locking in the event of a power failure.

The stationary part can be operated with as many loose parts as desired.

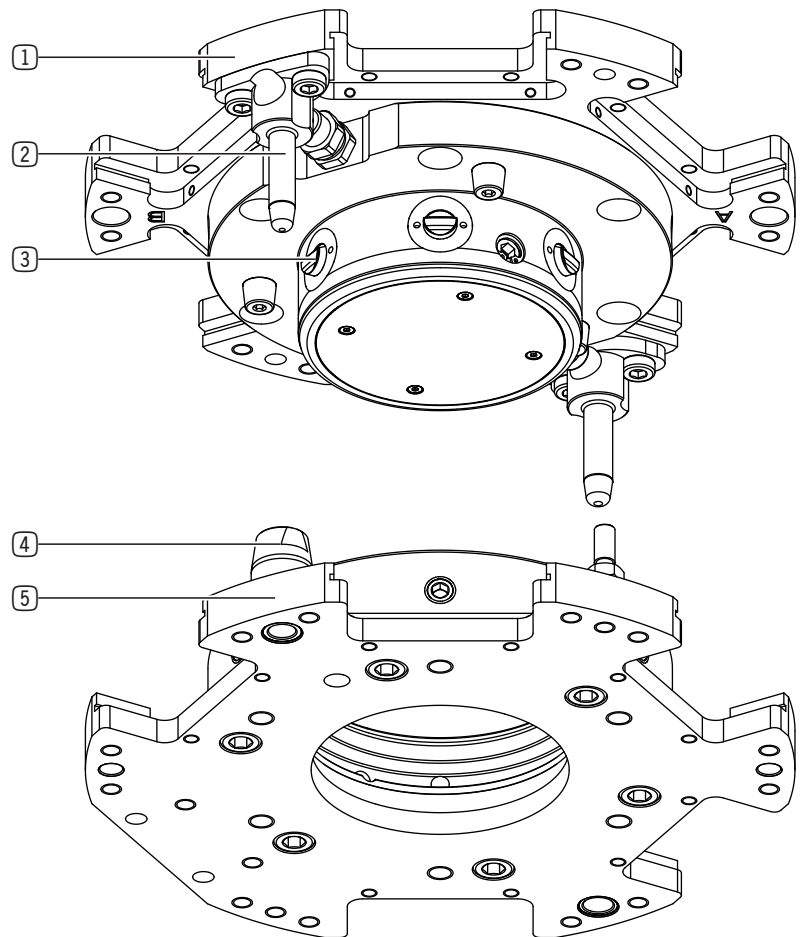

- ① Stationary part
- ② Centering pin
- ③ Locking bolt
- ④ Locking sleeve
- ⑤ Loose part

6.1 Functional safety

For the overall safety of the function, both components (stationary part and loose part) must be taken into account.

The safety function that ensures secure locking between the stationary and loose part of the product is implemented via two redundant action channels. They consist of a pneumatic locking and a mechanical safeguard via a spring.

7 Technical data

INFORMATION



- ▶ You can find the information in the technical data sheet on our website.
- ▶ This data varies within the series, depending on the specific design.
- ▶ Please contact Customer Service if you have any questions.

8 Accessories/scope of delivery

INFORMATION



- ▶ If any accessories not sold or authorized by Zimmer GmbH are used, the function of the product cannot be guaranteed. Zimmer GmbH accessories are specifically tailored to the individual products.
- ▶ For optional accessories and those included in the scope of delivery, refer to our website.

9 Transportation/storage/preservation

- ▶ Transport and storage of the product must be done only with the original packaging.
- ▶ If the product has already been installed on the superordinate machine unit, care must be taken during transport to ensure that no unexpected movements can occur.
 - ▶ Before commissioning the product and after transport, check all power and communication connections as well as all mechanical connections.
- ▶ If the product is stored for an extended period, the following points are to be observed:
 - ▶ Keep the storage location as dust-free and dry as possible.
 - ▶ Avoid temperature fluctuations.
 - ▶ Avoid wind/drafts/water condensation formation.
 - ▶ Pack the product and do not expose it to direct sunlight during storage.
- ▶ Clean all components. There must be no soiling left on the components.
- ▶ Visually inspect all components.
- ▶ Remove all foreign substances.
- ▶ Properly remove potential corrosion spots.
- ▶ Close electrical connections using suitable covers.

10 Installation

WARNING



Risk of injury due to uncontrolled movements

Risk of injury in case of unexpected movement of the machine or system into which the product is to be installed.

- ▶ Switch off the energy supply of the machine before any work.
- ▶ Secure the power supply against being switched on unintentionally.
- ▶ Check the machine for any residual energy that may be present.

INFORMATION



Further installation information:

- The mounting screws are not included in the scope of delivery.

Assembly requirements

Permissible flatness tolerance [mm]	0.05
Strength class of the mounting screws	8.8

- ▶ Install the product on an appropriate mounting surface in accordance with the flatness specifications.
- ▶ Make sure that the mounting piece is sufficiently rigid.
- ▶ Ensure the cleanliness of the connection surfaces.
- ▶ Please note the permitted tightening torques of the mounting screws at www.zimmer-group.com/en/td.

10.1 Installing the stationary part

INFORMATION



Various drilling patterns are available for the WWR1200 installation size.

- ▶ Insert the straight pin into the designated fit on the stationary part.
- ▶ Center the stationary part on the robot using the straight pin and the connection.
- ▶ Loosely attach the mounting screws.
- ▶ Tighten the mounting screws without distortion.

- ① Straight pins
- ② Connection
- ③ Mounting screw

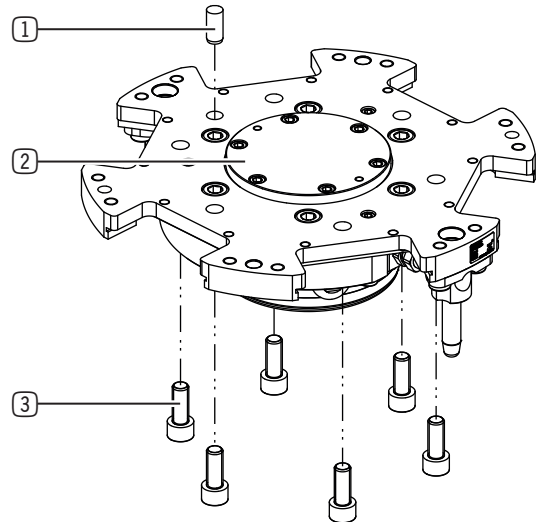

10.2 Installing the loose part

INFORMATION



Various drilling patterns are available for the WWR1200 installation size.

- ▶ Insert the straight pin into the designated fit on the loose part.
- ▶ Position the loose part on the tool.
- ▶ Loosely attach the mounting screws.
- ▶ Tighten the mounting screws without distortion.

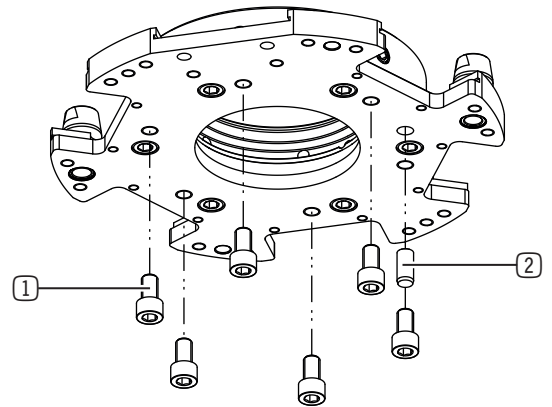

- ① Straight pins
- ② Mounting screw

10.3 Installing the energy supply

NOTICE



Non-compliance may result in material damage.

- ▶ You can find the information in the technical data sheet on our website.
- ▶ Close off unused connections using pressure-resistant closures.
- ▶ The authorized connections that are available can be found in the accessories list on our website. The necessary ordering information can also be found there.
- ▶ Use compressed air in accordance with DIN ISO 8573-1 [2:4:1].

- ▶ Mount the push-fit fitting.
 - ▶ Use the marked connections A and B for this purpose.

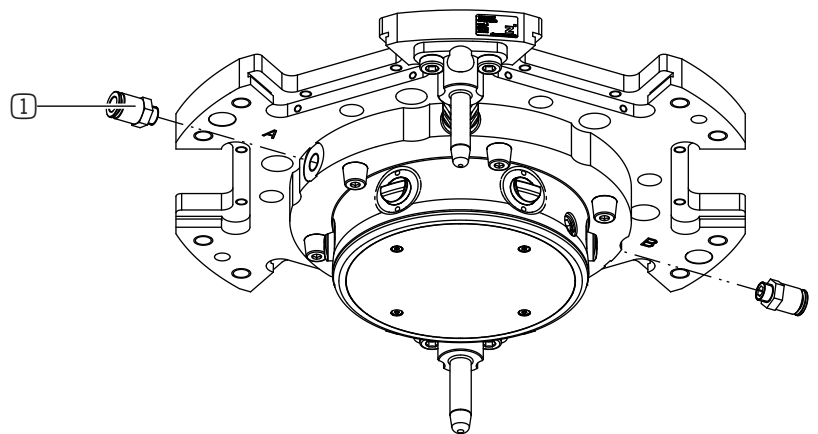

- ① Push-fit fitting

10.3.1 Pneumatic control

INFORMATION



- ▶ Please note that the connection to the A marking is used for product locking.
- ▶ Please note that the connection to the B marking is used for product unlocking.

The following examples show two control categories. In accordance with EN ISO 13849-1, the product can be controlled so that the required performance level is achieved.

INFORMATION



- The product can be actuated and operated using any control architecture in accordance with EN ISO 13849-1. The deciding factor here is which performance level PL_r should be achieved.
- ▶ Please note the $MTTF_d$ values of the safety-related parts of the control system (SRP/CS) being used as well as the degree of diagnostic coverage (DC) achieved.

INFORMATION



- The secure holding of coupled tools must be taken into account as this is a relevant safety function for the product.
- Risk prevention can be achieved through the use of various protection measures, both via SRP/CS measures as well as via non-SRP/CS measures. The goal of the protection measures is to reach a safe status.
- Measures for fault prevention suffice for applications with a risk of PL_{ra} to PL_{rc} .
- For applications with a risk higher than PL_{rd} to PL_{re} , the structure of the SRP/CS can provide the measures to avoid, note or tolerate the faults.
- Suitable measures include redundancy, diversity and monitoring in accordance with EN ISO 12100-2:2003, Section 3 and EN IEC 60204-1:2000.

10.3.1.1 Control category 1 example

Single-channel

The mechanical component (spring) is supported by the pneumatic component (pressure).

Both components alone cannot maintain the safety function.

- Proven components
- 0 Fault detection
- Activation via a 5/2-way valve

⇒ PL_c is achieved.

In order to achieve the safety function, the use of proven components in accordance with EN ISO 13849-1, Chapter 6.2.4 are sufficient.

- Magnetic field sensors S3 and S4 are available for the final position check.

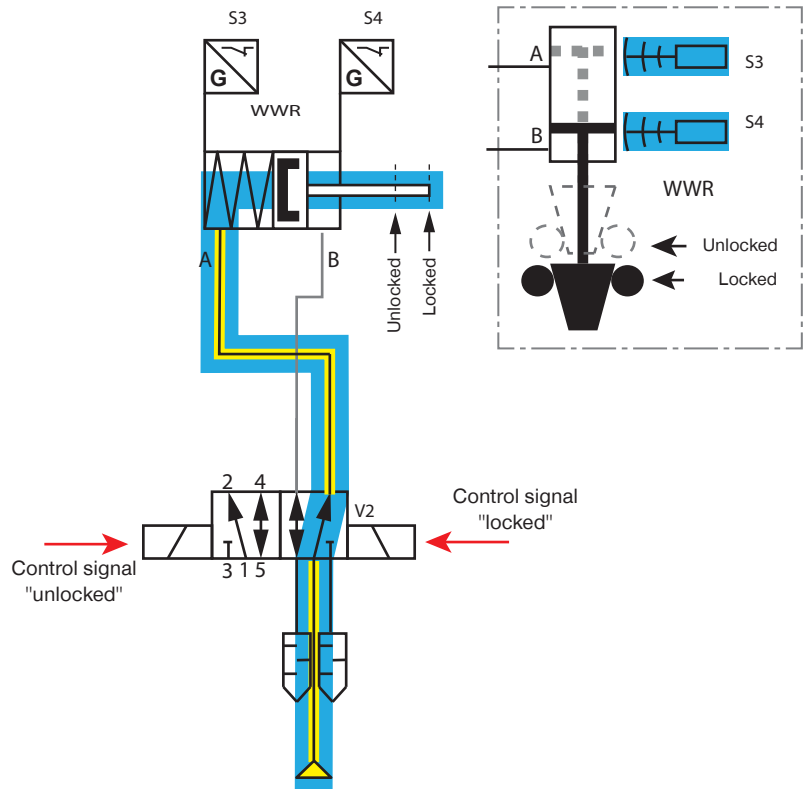

10.3.1.2 Control category 3 example

NOTICE



- ▶ Please note that the indicated maximum torque load and the maximum forces may not be exceeded for the implementation of control category 3.
- ▶ For information, refer to the technical data sheet.

Dual-channel

- The mechanical component (spring) operates as action channel 1 (yellow marking).
 - The pneumatic component (pressure) operates as action channel 2 (blue marking).
- ⇒ Each of the individual components alone can maintain the safety function.

There is fault elimination in accordance with EN ISO 13849-2, Annex A, Table A.5 for the mechanical action channel.

The following applies to the pneumatic action channel in the example:

- The degree of diagnostic coverage is $60\% \leq DC < 90\%$.
- Two mono-stable valves are used.
 - ⇒ The safety functions "reversing" and/or "unexpected startup" (unlock) are realized.
 - ⇒ PL_d to 100% can be achieved.
- Optional magnetic field sensors (S3 and S4) or a 2-point magnetic field sensor are available for the final position check.
- An optional pressure sensor can be used for pressure monitoring.
 - ⇒ This can increase the degree of diagnostic coverage to $90\% \leq DC < 99\%$.
- Optional sensors are available for storage station monitoring.
- Optional energy elements are available for tool coding.
- Optional sensors are available for "loose part present" sensing.

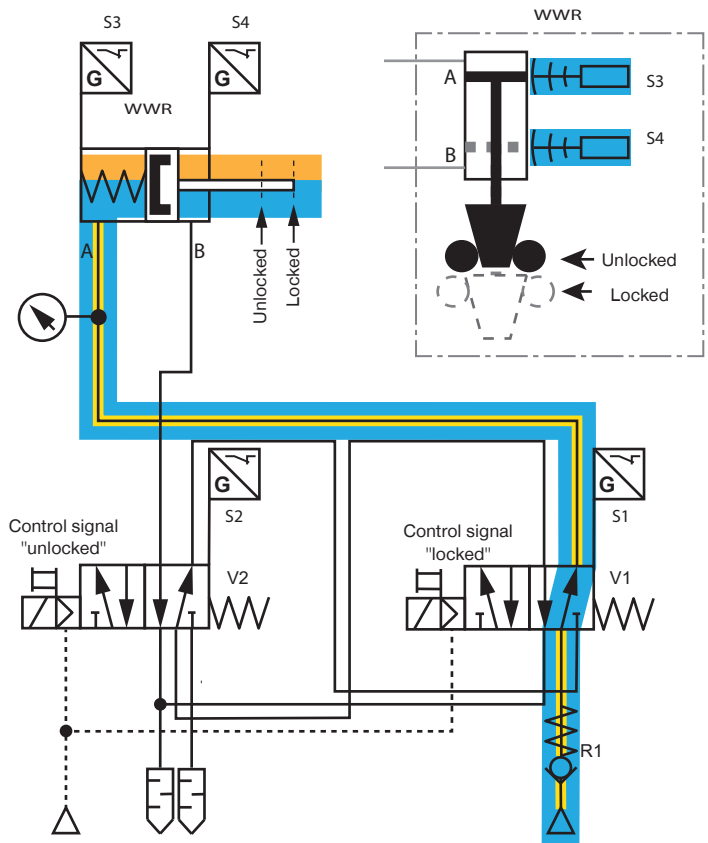

10.4 Mounting the inductive sensors

10.4.1 Sensing the piston position

Inductive sensors are available for sensing the piston position. These sensors provide information on the respective position of the piston and increase safety when operating the product.

- ▶ Remove the mounting screws.
- ▶ Push the sensors into the clamping bracket on the stationary part to the end stop.
- ▶ Clamp the sensors to the clamping brackets.

- ① Clamping bracket
- ② Sensor
- ③ Mounting screw

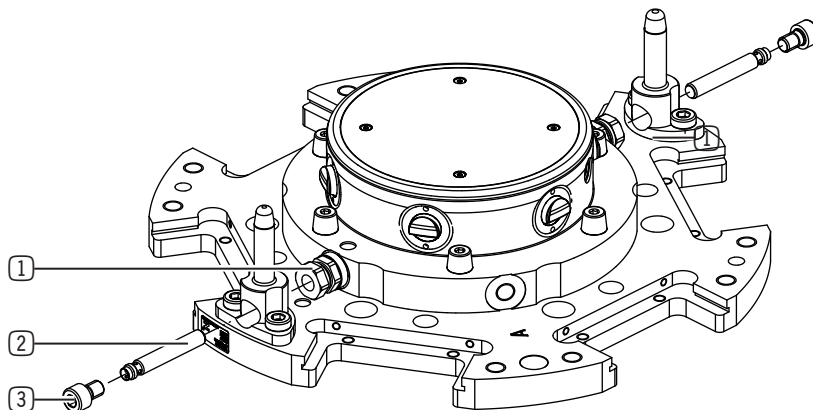

10.4.2 Sensing a loose part

The inductive sensor is used for product safety and senses whether a loose part is present.

- ▶ Slide the sensor into the borehole on the stationary part.
- ▶ Secure the sensor on the stationary part with the lock nuts.
- ▶ If necessary, secure the sensor to the opposite side of the product.

- ① Sensor
- ② Lock nut
- ③ Damping element

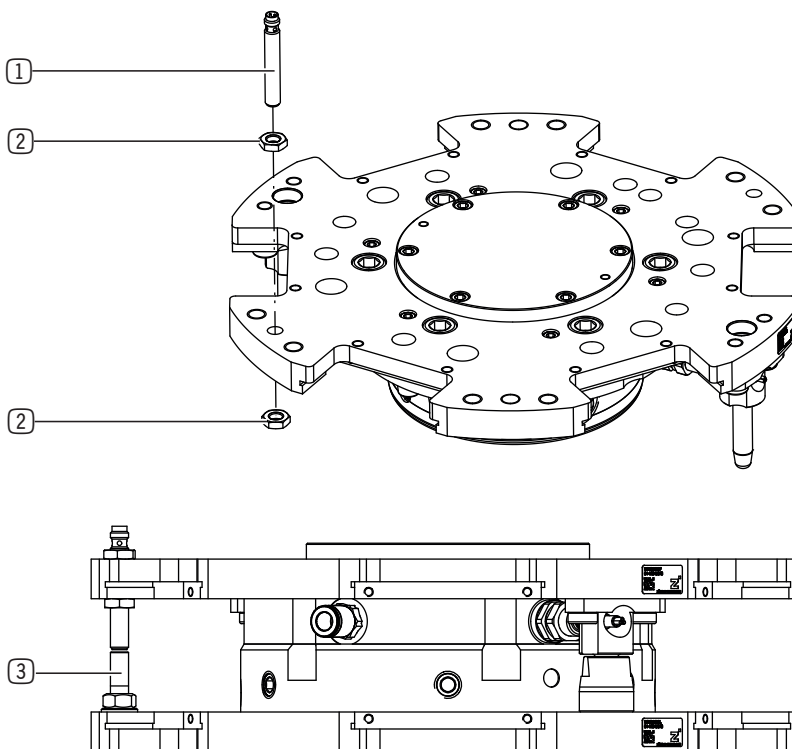

10.5 Installing the storage station

The storage station is a device in which a completely equipped loose part can be held ready in a defined position.

- ▶ Install the supplied spacer plate for the installation size WWR1160.
- ▶ Position the mount on the mounting piece using straight pins.
- ▶ Install the mount on the mounting piece using the mounting screws.
- ▶ Tighten the mounting screws without distortion.

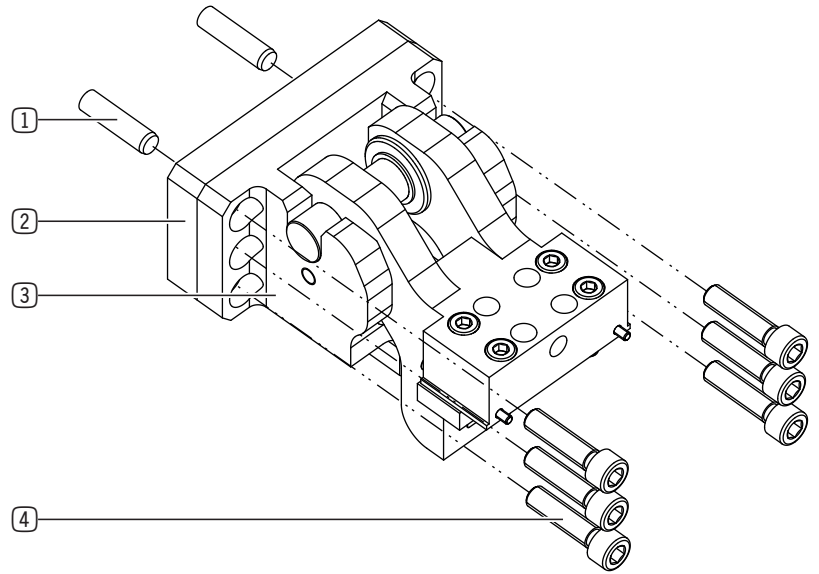

- ① Straight pins
- ② Spacer plate
- ③ Mount
- ④ Mounting screw

- ▶ Slide the clamping plate into the groove on the claw.

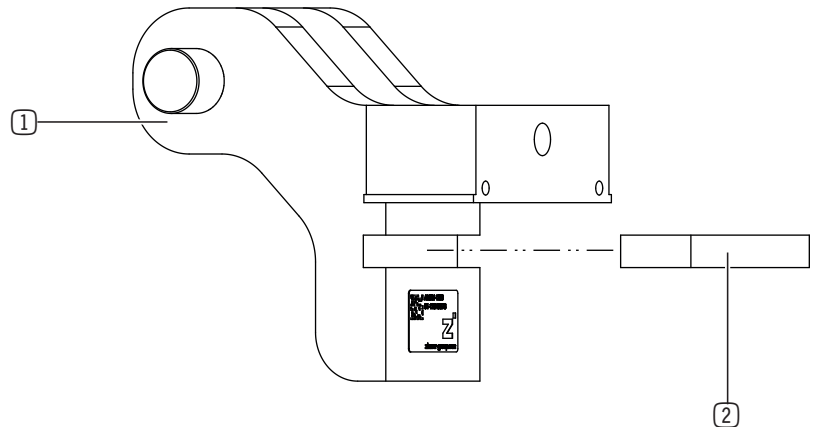

- ① Claw
- ② Clamping plate

- ▶ Slide the claw with the clamping plate into the mating part on the loose part intended for this.
- ▶ Fasten the storage station using the mounting screws.
- ▶ Tighten the mounting screws without distortion.

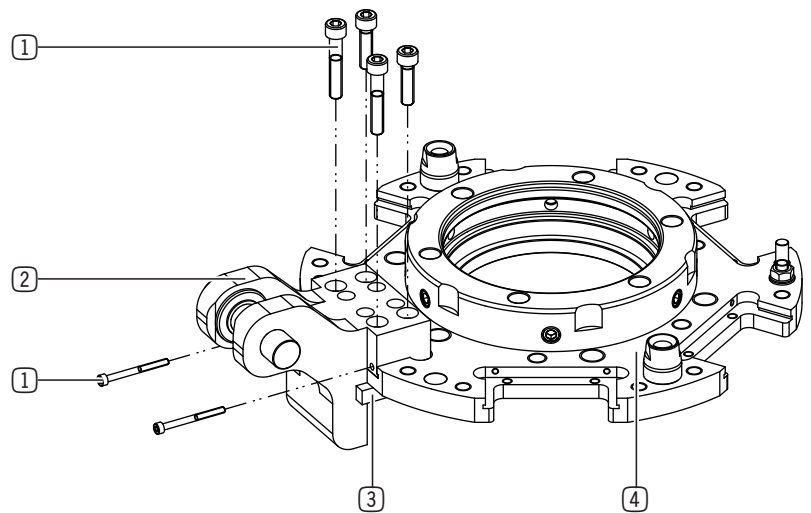

- ① Mounting screw
- ② Claw
- ③ Clamping plate
- ④ Loose part

- ▶ Place the loose part with the mounted claw in the mount.

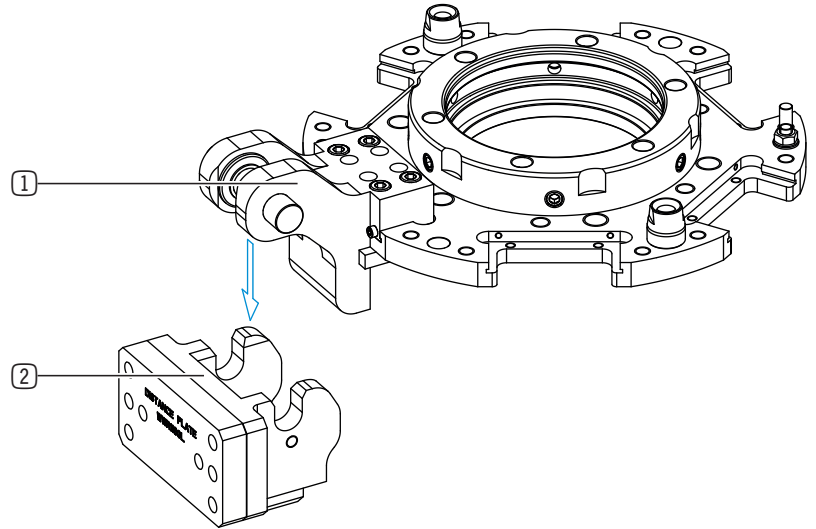

- ① Claw
- ② Mount

- ▶ Loosen the lock nut.
- ▶ Set the desired inclination for the storage station with the adjustment bolt.
- ▶ Retighten the lock nut.

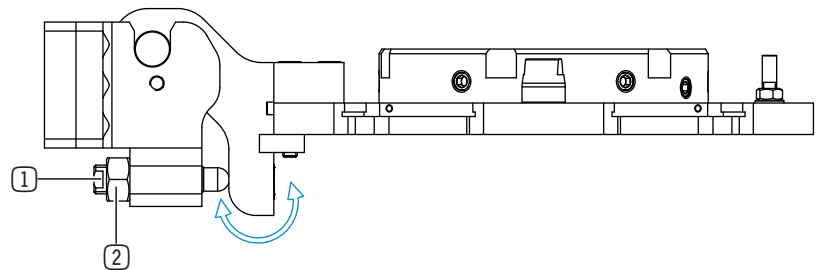

- ① Adjustment bolt
- ② Lock nut

11 Operation

11.1 Emergency release

If the loose part does not detach from the stationary part, for example due to a crash, you can manually separate the parts.

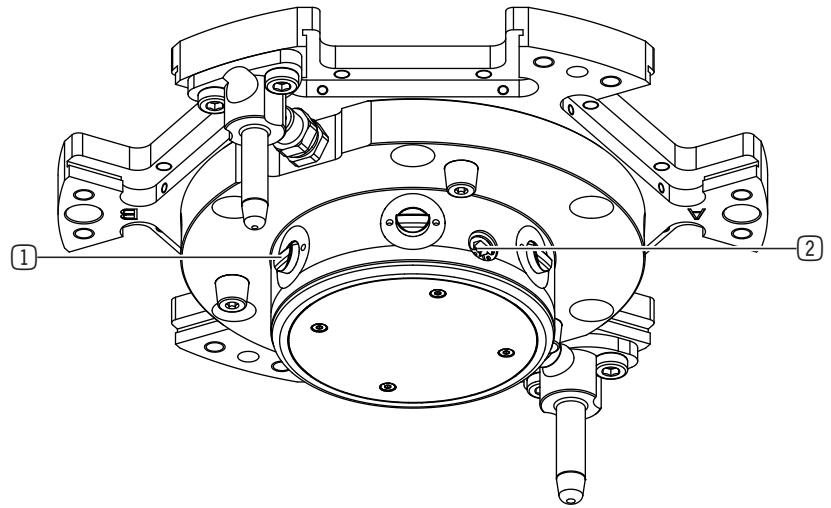

- ① Locking bolt
- ② Emergency release

- ▶ Remove the grub screw on the loose part with an Allen key to access the emergency release of the stationary part.
 - ▶ Screw in the emergency release on both sides with an Allen key.
- ⇒ The piston will be reset.

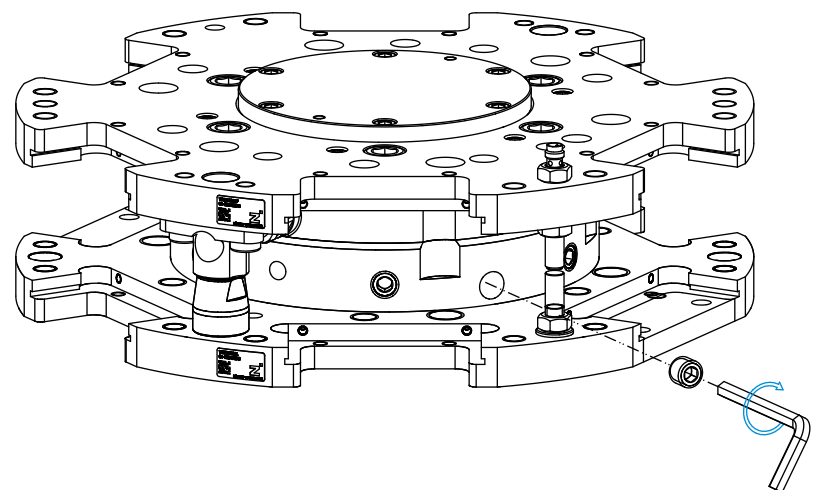

Design size	Wrench size [mm]
WWR1200	6
WWR1160	6

- ▶ Remove the grub screw on the loose part with an Allen key to access the locking bolt of the stationary part.

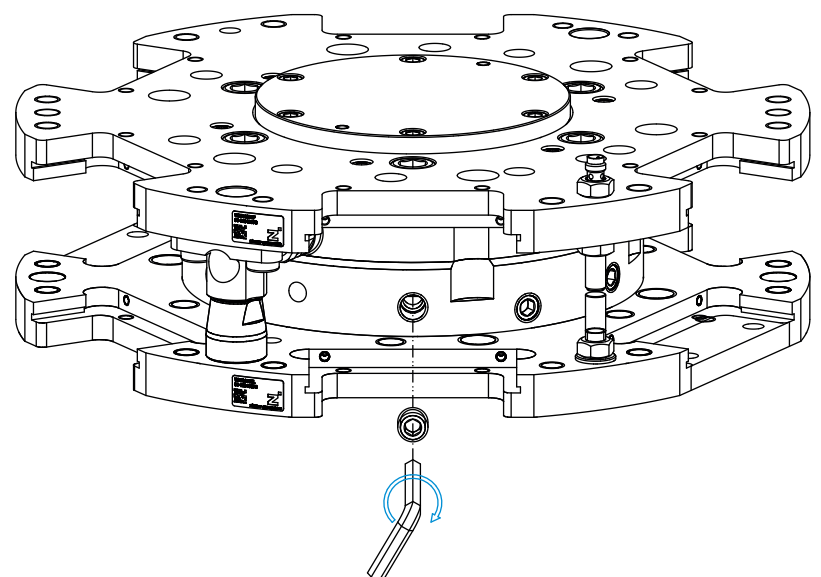

- ▶ Press the locking bolts inward with a blunt object.
- ▶ Separate the stationary part from the loose part.

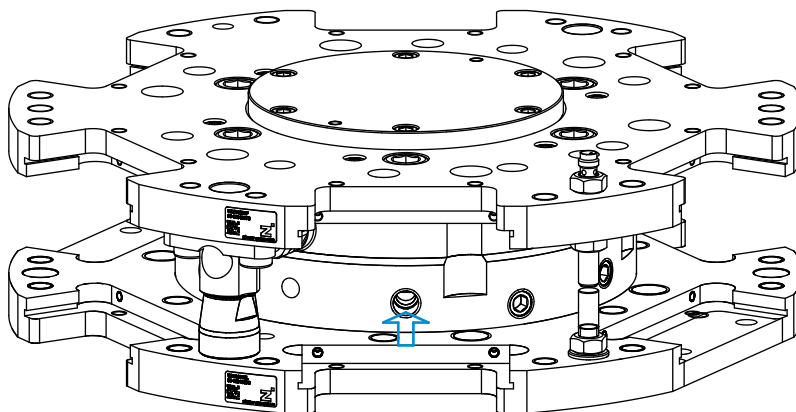

12 Maintenance

NOTICE



Material damage resulting from blowing out with compressed air

Blowing out the product with compressed air can cause malfunctions and pose a risk of accidents.

- ▶ Never purge the product with compressed air.

NOTICE



Material damage caused by unsuitable cleaning materials

Liquid and solvent-based cleaning agents can cause malfunctions and pose a risk of accidents.

- ▶ Do not clean the product with any cleaning agents that are liquid or contain solvents.

Maintenance-free operation of the product is guaranteed for up to **5 million cycles**.

- ▶ Note that the product could become damaged under the following circumstances:
 - Operation with impermissible compressed air
 - Dirty environment
 - Improper use and use that does not comply with the performance data
 - Permissible temperature range not observed
 - ▶ Even though the product is maintenance-free as mentioned above, perform a regular visual inspection to check for any damage or contamination.
 - ▶ Have maintenance work that requires disassembly of the product performed by customer service only.
- ⇒ Dismantling and reassembling the product without authorization may result in complications, as special installation equipment is required in some cases. Zimmer GmbH accepts no liability for any resulting malfunctions or damage.

13 Decommissioning/disposal

INFORMATION



When the product reaches the end of its operational phase, it can be completely disassembled and disposed of.

- ▶ Disconnect the product completely from the power supply.
- ▶ Dispose of the components properly according to the material groups.
- ▶ Comply with the locally applicable environmental and disposal regulations.

14 Declaration of Incorporation

In terms of the EU Machinery Directive 2006/42/EC (Annex II 1 B)

Name and address of the manufacturer:

Zimmer GmbH

 Im Salmenkopf
 77866 Rheinau, Germany
 +49 7844 9138 0
 info@zimmer-group.com
 www.zimmer-group.com

We hereby declare that the incomplete machine described below

Product designation: Pneumatic tool changer
Type designation: WWR1000

conform to the requirements of the Machinery Directive, 2006/42/EC, Article 2g, Annex VII.b – Annex II.b, in its design and the version we put on the market.

Basic health and safety requirements:

No. 1.1.2, No. 1.1.3, No. 1.1.5, No. 1.3.2, No. 1.3.4, No. 1.3.7, No. 1.3.9, No. 1.5.3, No. 1.5.4, No. 1.6.4, No. 1.7.1, No. 1.7.4

A full list of applied standards can be obtained from the manufacturer.

We also declare that the specific technical documents were produced in accordance with Annex VII Part B of this Directive. We undertake to provide the market supervisory bodies with electronic versions of special documents for the incomplete machine through our documentation department, should they have reason to request them.

The incomplete machine may only be commissioned if it has been ascertained, if applicable, that the machine or system in which the incomplete machine is to be installed satisfies the requirements of Directive 2006/42/EC on Machinery and an EC Declaration of Conformity has been drawn up in accordance with Annex II 1 A.

Kurt Ross

Authorized representative for the compilation of relevant technical documents

Rheinau, Germany, 2018-06-25

(Place and date of issuance)



Martin Zimmer
 (Legally binding signature)
 Managing Partner

15 REACH declaration

In terms of the EC Regulation 1907/2006

Name and address of the manufacturer:

Zimmer GmbH

📍 Im Salmenkopf
77866 Rheinau, Germany
☎ +49 7844 9138 0
✉ info@zimmer-group.com
🌐 www.zimmer-group.com

REACH stands for **R**egistration, **E**valuation, **A**uthorisation and **R**estriction of **C**hemicals.

A full declaration of REACH can be obtained from the manufacturer due to the duty to notify in accordance with Art. 33 of the REACH regulation (“Duty to communicate information on substances in articles”).

Michael Hoch

Authorized representative for the
compilation of relevant technical
documents

Rheinau, Germany, 2018-06-25

(Place and date of issuance)



Martin Zimmer
(Legally binding signature)
Managing Partner