

## INSTALLATION AND OPERATING INSTRUCTIONS

2-jaw parallel gripper with long  
stroke, pneumatic

GHK6000

DDOC00313

THE KNOW-HOW FACTORY



**Content**

1 Supporting documents ..... 4  
 1.1 Notices and graphics in the installation and operating instructions ..... 4

2 Safety notices ..... 5

3 Proper use ..... 5

4 Personnel qualification ..... 6

5 Product description ..... 6  
 5.1 Type plate ..... 6

6 Functional description ..... 6

7 Technical data ..... 6

8 Accessories/scope of delivery ..... 6

9 Transportation/storage/preservation ..... 7

10 Installation ..... 8  
 10.1 Installing the product ..... 9  
 10.2 Installing the energy supply ..... 9  
 10.3 Installing the sensors ..... 10  
     10.3.1 Adjusting the magnetic field sensors ..... 10  
     10.3.2 Setting the inductive sensors ..... 10  
 10.4 Installing accessories ..... 10

11 Maintenance ..... 11

12 Decommissioning/disposal ..... 11

13 Declaration of Incorporation ..... 12

## 1 Supporting documents

### NOTICE



Read through the installation and operating instructions before installing or working with the product.

The installation and operating instructions contain important notes for your personal safety. They must be read and understood by all persons who work with or handle the product during any phase of the product lifetime.



The documents listed below are available for download on our website [www.zimmer-group.com](http://www.zimmer-group.com).

- Installation and operating instructions
  - Catalogs, drawings, CAD data, performance data
  - Information on accessories
  - Technical data sheets
  - General Terms and Conditions, including warranty information.
- ⇒ Only those documents currently available on the website are valid.

In these installation and operating instructions, "product" refers to the product designation on the title page!

### 1.1 Notices and graphics in the installation and operating instructions

#### DANGER



This notice warns of an imminent danger to the life and health of people. Ignoring these notices can lead to serious injury or even death.

- ▶ You absolutely must comply with the described measures for avoiding these dangers!
- ⇒ The warning symbols are assigned according to the type of danger.

#### WARNING



This notice warns of a situation that is potentially hazardous to personal health. Ignoring these notices can cause serious injury or damage to health.

- ▶ You absolutely must comply with the described measures for avoiding these dangers!
- ⇒ The warning symbols are assigned according to the type of danger.

#### CAUTION



This notice warns of a situation that is potentially hazardous for people or that may result in material or environmental damage. Ignoring these notices may result in slight, temporary injuries or damage to the product or to the environment.

- ▶ You absolutely must comply with the described measures for avoiding these dangers!
- ⇒ The warning symbols are assigned according to the type of danger.

#### NOTICE



General notices contain usage tips and valuable information, but no warnings of dangers to health.

#### INFORMATION



This category contains useful tips for handling the product efficiently. Failure to observe these tips will not result in damage to the product. This information does not include any information relevant to health or workplace safety.

## 2 Safety notices

### CAUTION



#### Risk of injury and material damage in case of non-compliance

Installation, commissioning, maintenance and repairs may only be performed by qualified specialists in accordance with these installation and operating instructions.

The product is state-of-the-art.

It is fitted to industrial machines and is used to hold, transport and store workpieces.

The following are examples of situations in which the product may cause a hazard:

- The product is not properly installed, used or maintained.
- The product is not used for its designated purpose.
- The locally applicable regulations, laws, directives or guidelines are not observed.
- ▶ The product may only be used in accordance with these installation and operating instructions and the product's technical data. Any changes or additions to the intended use of the product, as well as modifications to the product, such as those in the following examples, require the written permission of the manufacturer:
  - Use of the product under extreme conditions, such as aggressive fluids or abrasive dusts
  - Additional drilled holes or threads
- ⇒ Zimmer GmbH shall accept no liability for any damage caused by improper use. The operator bears sole responsibility.
- ▶ Make sure that the power supply is disconnected before you mount, adjust, modify, maintain or repair the product.
- ▶ Whenever work is carried out on the product, make sure that the product cannot be actuated by mistake.
- ▶ Perform maintenance tasks, renovation work or attachment work outside of the machine's danger zone when possible.
- ▶ Do not reach into the operational range of the product.
- ▶ Note that, due to the spring tension, you should exercise increased caution when uninstalling products with integrated springs.
- ▶ Observe the specified maintenance intervals and specifications regarding the quality of the operating material.
- ▶ When using the product under extreme conditions, adjust the maintenance interval according to the degree of contamination.

## 3 Proper use

### NOTICE



The product is only to be used in its original state with its original accessories, with no unauthorized changes and within the stipulated parameter limits and operating conditions.

Any other or secondary use is deemed improper.

- ▶ Operate the product only in compliance with the associated installation and operating instructions.
- ▶ Operate the product only when it is in a technical condition that corresponds to the guaranteed parameters and operating conditions.
- ⇒ Zimmer GmbH shall accept no liability for any damage caused by improper use. The operator bears sole responsibility.

The product is designed exclusively for pneumatic operation.

The product is to be used as intended in enclosed rooms for temporary gripping, handling and holding.

The product is not suitable for clamping workpieces during a machining process.

Direct contact with perishable goods/food is not permitted.

## 4 Personnel qualification

Installation, commissioning and maintenance may only be performed by trained specialists. These persons must have read and understood the installation and operating instructions in full.

## 5 Product description

### 5.1 Type plate

A type plate is attached to the housing of the product.

The article number and the confirmation number are shown on the type plate.

- ① Article number
- ② Confirmation number

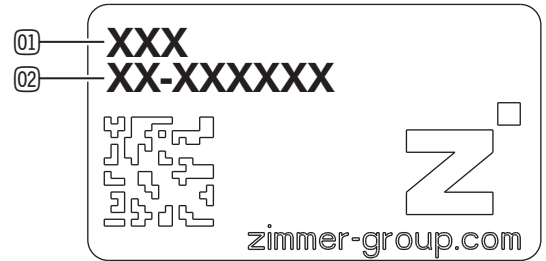

## 6 Functional description

The product has a double-acting pneumatic rotor cylinder.

Alternating ventilation sets the gripper jaws in motion.

The movement generated in this process is transferred to the gripper jaws by kinematics, producing the gripper jaw movement.

The clamping element is used to secure the position.

- ① Clamping element

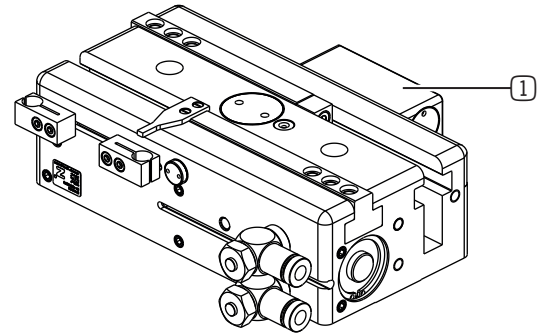

## 7 Technical data

### INFORMATION



► You can find the information in the technical data sheet on our website.

This data varies within the series, depending on the specific design.

► Please contact Zimmer Customer Service if you have any questions.

## 8 Accessories/scope of delivery

### INFORMATION



If any accessories not sold or authorized by Zimmer GmbH are used, the function of the product cannot be guaranteed. Zimmer GmbH accessories are specifically tailored to the individual products.

► For optional accessories and those included in the scope of delivery, refer to our website.

## 9 Transportation/storage/preservation

- ▶ Transport and storage of the product must be done only with the original packaging.
- ▶ If the product has already been installed on the superordinate machine unit, care must be taken during transport to ensure that no unexpected movements can occur.
  - ▶ Before commissioning the product and after transport, check all power and communication connections as well as all mechanical connections.
- ▶ If the product is stored for an extended period, the following points are to be observed:
  - ▶ Keep the storage location as dust-free and dry as possible.
  - ▶ Avoid temperature fluctuations.
  - ▶ Avoid wind/drafts/water condensation formation.
  - ▶ Pack the product and do not expose it to direct sunlight during storage.
- ▶ Clean all components. There must be no soiling left on the components.
- ▶ Visually inspect all components.
- ▶ Remove all foreign substances.
- ▶ Properly remove potential corrosion spots.
- ▶ Close off unused connections using pressure-resistant closures.

## 10 Installation

### WARNING



#### Risk of injury due to uncontrolled movements

Risk of injury in case of unexpected movement of the machine or system into which the product is to be installed.

- ▶ Switch off the energy supply of the machine before any work.
- ▶ Secure the power supply against being switched on unintentionally.
- ▶ Check the machine for any residual energy that may be present.
- ▶ For spring-assisted products, wait until the gripper jaws reach the end position with the system depressurized.

### CAUTION



#### Risk of injury due to uncontrolled movements

Risk of injury in the event of uncontrolled movement of the product when the power supply is connected.

- ▶ Switch off the power supply to the machine before carrying out any work.
- ▶ Secure the power supply against being switched on unintentionally.
- ▶ Check the machine for any residual energy that may be present.

### NOTICE



▶ Installation may only be carried out by qualified personnel in accordance with these installation and operating instructions.

▶ Switch off the power supply before any assembly, installation or maintenance work.

▶ Install the product on an appropriate mounting surface in accordance with the flatness specifications.

### INFORMATION



Requirements for a mounting surface with a length < 100 mm:

- Permissible unevenness [mm]: 0.02

Requirements for a mounting surface with a length > 100 mm:

- Permissible unevenness [mm]: 0.05

Further installation information:

- The mounting screws are not included in the scope of delivery.
- Strength class of the mounting screws 8.8 (DIN EN ISO 4762)

▶ Make sure that the mounting piece is sufficiently rigid.

▶ Observe the tightening torque of the mounting screws.

▶ Verify the permitted load capacity of the required screw connections in accordance with VDI 2230.



### 10.1 Installing the product

- ▶ Insert the straight pins into the designated fits on the product.
- ▶ Use the straight pins to position the product on the mounting piece.
- ▶ Mount the product on the mounting piece using the appropriate mounting screws.

Option 1

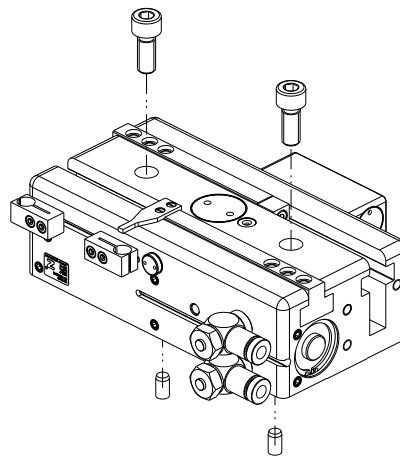

Option 2

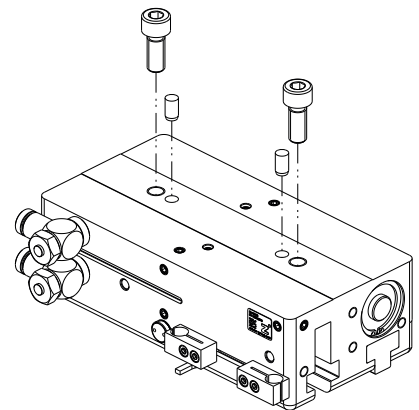

### INFORMATION



- ▶ Use an adapter plate if necessary.
- ▶ For information on optional accessories and those included in the scope of delivery, refer to our website.

### 10.2 Installing the energy supply

#### NOTICE



- ▶ You can find the information in the technical data sheet on our website.
- ▶ Close off unused connections using pressure-resistant closures.
- ▶ The authorized connections that are available can be found in the accessories list on our website. The necessary ordering information can also be found there.
- ▶ Use compressed air in accordance with DIN ISO 8573-1 [4:4:4].

- ▶ Remove the pressure-resistant closure from the connection.
- ▶ Insert the screw fitting into the connection designated for this purpose.

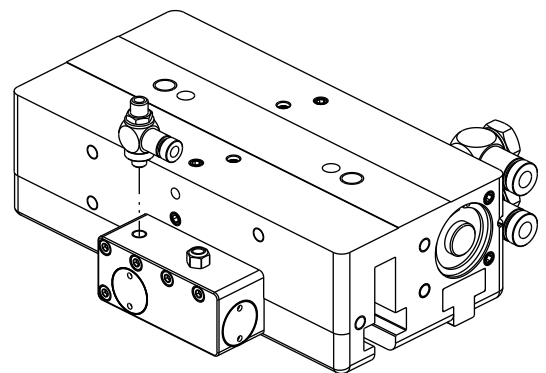

### 10.3 Installing the sensors

#### 10.3.1 Adjusting the magnetic field sensors

##### NOTICE



- ▶ Note that switching point shifts may occur if the sensors are exposed to an additional, external magnetic field.

##### INFORMATION



- ▶ The sensors are available as accessories.
- ▶ More information can be found in the installation and operating instructions of the sensor.

#### 10.3.2 Setting the inductive sensors

##### INFORMATION



- ▶ External limit stops are a requirement to use inductive sensors.
- ▶ For information on optional accessories and those included in the scope of delivery, refer to our website.

- ▶ Switch off the power supply.
- ▶ Slide the sensor into the terminal block.
- ▶ Position the sensor at an appropriate switching distance from the switch cam.
- ▶ Clamp the sensor.

- ① Switch cam
- ② Terminal block
- ③ Inductive sensor

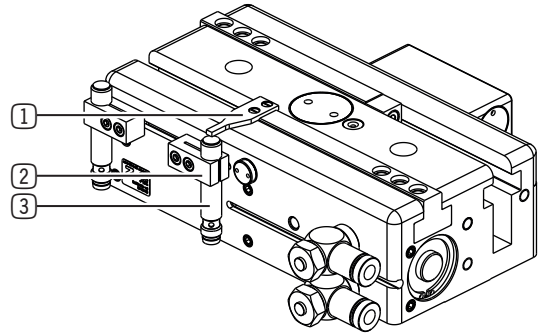

### 10.4 Installing accessories

##### NOTICE



- ▶ Before installing an accessory, make sure it is suitable for use with the selected variant.
- ▶ You can find information on our website.
- ▶ Please contact Zimmer Customer Service if you have any questions.

## 11 Maintenance

### CAUTION



#### Material damage resulting from blowing out with compressed air

Blowing out the product with compressed air can cause malfunctions and pose a risk of accidents.

- ▶ Never purge the product with compressed air.

### CAUTION



#### Material damage caused by liquid and solvent-based cleaners

Liquid and solvent-based cleaning agents can cause malfunctions and pose a risk of accidents.

- ▶ Do not clean the product with any cleaning agents that are liquid or contain solvents.

### NOTICE



#### Material damage due to leaking lubricant

Excessive lubrication can cause moving machine parts to leak lubricant. This can contaminate the machine, object being gripped or workpiece.

- ▶ Only use approved or recommended lubricants.
- ▶ Observe the manufacturer information for use of specific lubricants.
- ▶ Adhere to the lubrication interval.
- ▶ Avoid excessive lubrication.
- ▶ Remove leaking lubricant immediately and thoroughly.
- ▶ Replace damaged seals.

Maintenance-free operation of the product is guaranteed for up to 10 million cycles.

Maintenance-free operation of the product can be reduced under the following circumstances:

- Operation with impermissible compressed air
  - Dirty environment
  - Improper use and use that does not comply with the power specifications.
  - Permissible temperature range not observed
  - ▶ Even though the product is maintenance-free as mentioned above, perform a regular visual inspection to check for any damage or contamination.
  - ▶ Have maintenance work be performed by Zimmer Customer Service whenever possible.
- ⇒ Dismantling and reassembling the product without authorization may result in complications, as special installation equipment is required in some cases. Zimmer GmbH accepts no liability for any resulting malfunctions or damage.

## 12 Decommissioning/disposal

### INFORMATION



When the product reaches the end of its operational phase, it can be completely disassembled and disposed of.

- ▶ Disconnect the product completely from the power supply.
- ▶ Dispose of the components properly according to the material groups.
- ▶ Comply with the locally applicable environmental and disposal regulations.

### 13 Declaration of Incorporation

In terms of the EU Machinery Directive 2006/42/EC (Annex II 1 B)

**Name and address of the manufacturer:**

**Zimmer GmbH**

- 📍 Im Salmenkopf  
77866 Rheinau, Germany
- ☎ +49 7844 9138 0
- ✉ [info@zimmer-group.com](mailto:info@zimmer-group.com)
- 🌐 [www.zimmer-group.com](http://www.zimmer-group.com)

We hereby declare that the incomplete machine described below

- Product designation:** 2-jaw parallel gripper with long stroke, pneumatic
- Type designation:** GHK6000

conform to the requirements of the Machinery Directive, 2006/42/EC, Article 2g, Annex VII.b – Annex II.b, in its design and the version we put on the market.

Basic health and safety requirements:

No. 1.1.2, No. 1.1.3, No. 1.1.5, No. 1.3.2, No. 1.3.4, No. 1.3.7, No. 1.5.3, No. 1.5.4, No. 1.6.4, No. 1.7.1, No. 1.7.4

A full list of applied standards can be obtained from the manufacturer.

We also declare that the specific technical documents were produced in accordance with Annex VII Part B of this Directive. We undertake to provide the market supervisory bodies with electronic versions of special documents for the incomplete machine through our documentation department, should they have reason to request them.

**The incomplete machine may only be commissioned if it has been ascertained, if applicable, that the machine or system in which the incomplete machine is to be installed satisfies the requirements of Directive 2006/42/EC on Machinery and an EC Declaration of Conformity has been drawn up in accordance with Annex II 1 A.**

Kurt Ross

Authorized representative for the compilation of relevant technical documents

Rheinau, Germany, 2019-01-14

(Place and date of issuance)

Martin Zimmer  
(Legally binding signature)  
Managing Partner