

INSTALLATION AND OPERATING INSTRUCTIONS

2-point magnetic field sensor

MFS01-K-KHC-P2-PNP
MFS01-S-KHC-P2-PNP
MFS02-K-KHC-P2-PNP
MFS02-S-KHC-P2-PNP
DDOC00537

THE KNOW-HOW FACTORY

Content

1 Supporting documents 4

2 Safety notices 4

3 Proper use 4

4 Personnel qualification 4

5 Product description 5

6 Technical data 6

7 Installation 6

 7.1 Installing MFS01-S-KHC-P2-PNP and MFS01-K-KHC-P2-PNP 6

 7.2 Installing MFS02-S-KHC-P2-PNP and MFS02-K-KHC-P2-PNP 7

8 Commissioning 8

 8.1 Defining switching points 8

 8.2 Checking switching points 8

9 Maintenance 9

10 Decommissioning/disposal 9

11 Declaration of Conformity 10

1 Supporting documents

NOTICE



Read through the installation and operating instructions before installing or working with the product.

The installation and operating instructions contain important notes for your personal safety. They must be read and understood by all persons who work with or handle the product during any phase of the product lifetime.



The documents listed below are available for download on our website www.zimmer-group.com.

- Installation and operating instructions
- Catalogs, drawings, CAD data, performance data
- Information on accessories
- Technical data sheets
- General Terms and Conditions, including warranty information.

⇒ Only those documents currently available on the website are valid.

In these installation and operating instructions, "product" refers to the product designation on the title page!

2 Safety notices

NOTICE



In accordance with the EC Machinery Directive, the product is not a safety component.

3 Proper use

NOTICE



The product is only to be used in its original state with its original accessories, with no unauthorized changes and within the stipulated parameter limits and operating conditions.

Any other or secondary use is deemed improper.

- ▶ Operate the product only in compliance with the associated installation and operating instructions.
- ▶ Operate the product only when it is in a technical condition that corresponds to the guaranteed parameters and operating conditions.

⇒ Zimmer GmbH shall accept no liability for any damage caused by improper use. The operator bears sole responsibility.

4 Personnel qualification

Installation, commissioning and maintenance may only be performed by trained specialists. These persons must have read and understood the installation and operating instructions in full.

5 Product description

MFS01-K-KHC-P2-PNP

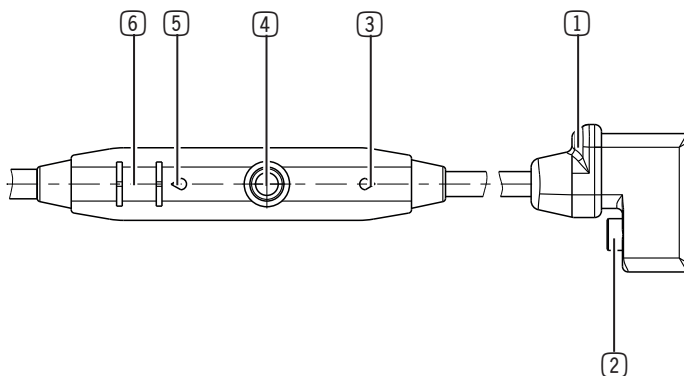

MFS01-S-KHC-P2-PNP

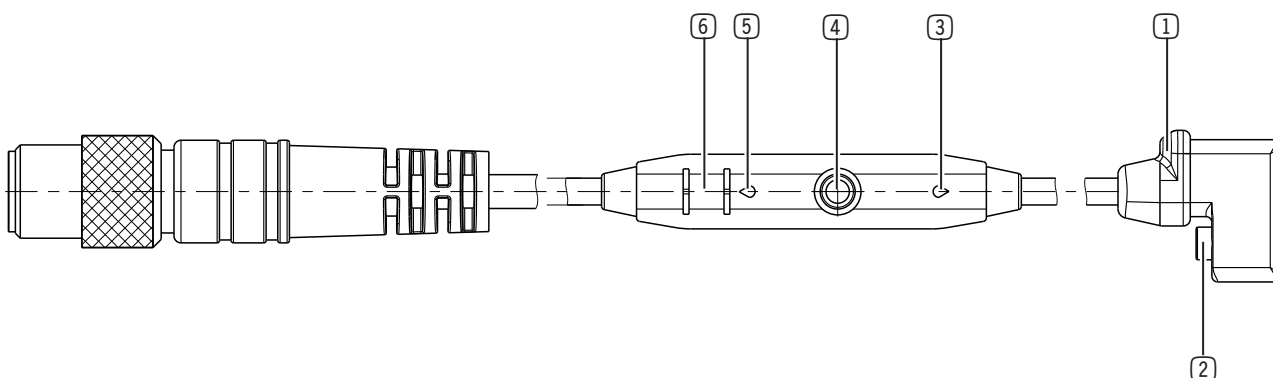

MFS02-K-KHC-P2-PNP

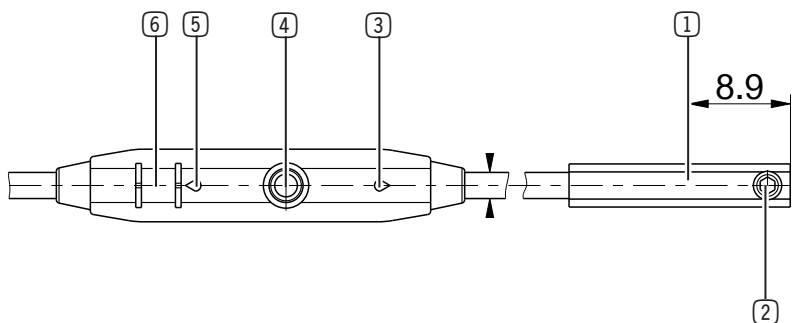

MFS02-S-KHC-P2-PNP

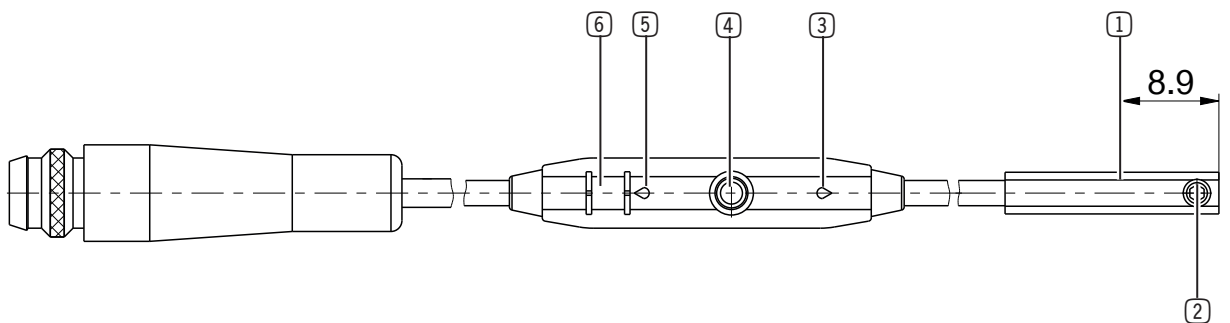

- ① Center of the sensor element
- ② Mounting screw
- ③ LED display
- ④ Teach-in button
- ⑤ LED display
- ⑥ Ribs for cable ties

6 Technical data

INFORMATION



- ▶ You can find the information in the technical data sheet on our website.
- ▶ This data varies within the series, depending on the specific design.
- ▶ Please contact Zimmer Customer Service if you have any questions.

7 Installation

7.1 Installing MFS01-S-KHC-P2-PNP and MFS01-K-KHC-P2-PNP

NOTICE



- ▶ Use the included Allen key and/or plastic pin for installation.

INFORMATION



- ▶ The sensors can be used for all Zimmer GmbH products with a compatible C-groove and switching distance.
- ▶ You can find the information in the technical data sheet on our website.

- ▶ Slide the sensor into the C-groove from above.
- ▶ Align the sensor in the center.

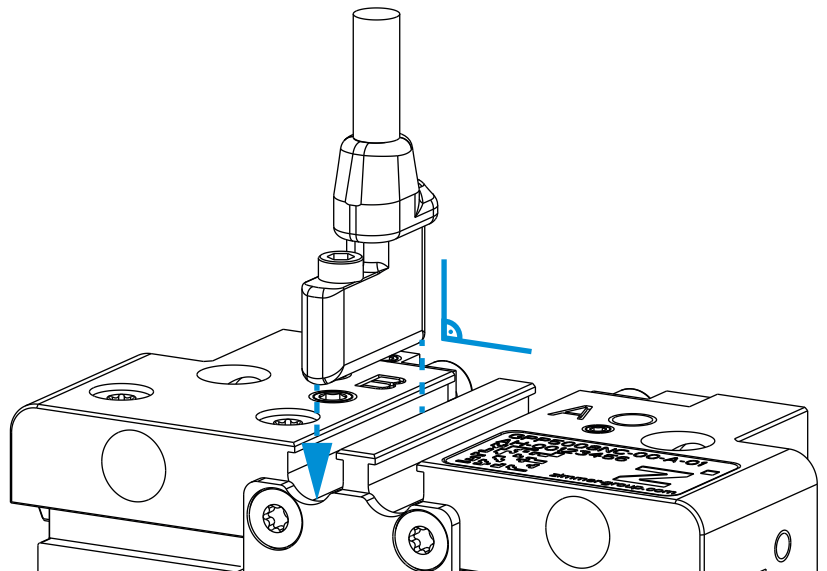

INFORMATION



- ▶ Comply with the tightening torque of 0.1 Nm.

- ▶ Tighten the mounting screw using an Allen key.

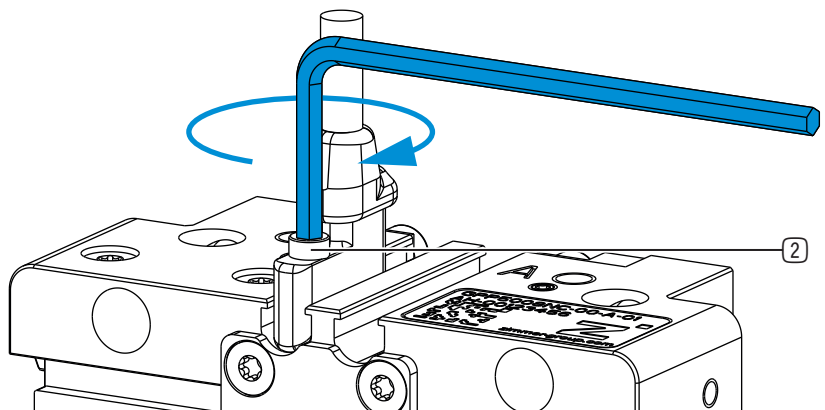

② Mounting screw

7.2 Installing MFS02-S-KHC-P2-PNP and MFS02-K-KHC-P2-PNP

- ▶ Push the sensor into the C-groove from above with the mounting screw pointing downwards.
- ▶ Align the sensor in the center.

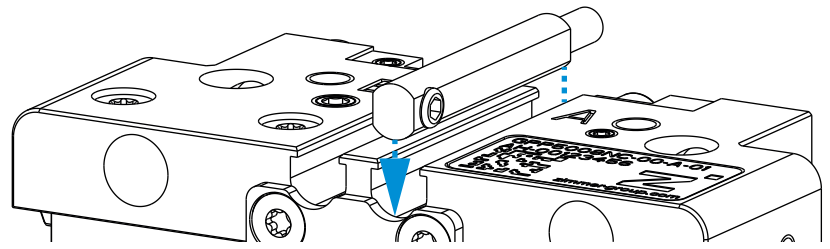

- ▶ Turn the sensor by 90° so that the mounting screw points upwards.

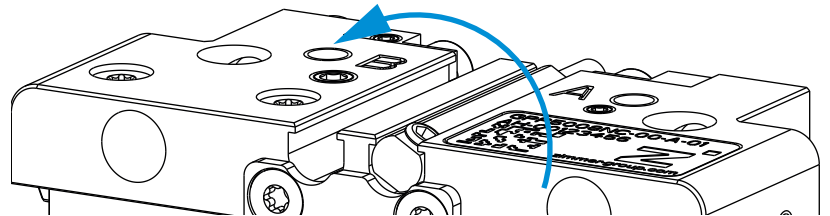

INFORMATION



- ▶ Comply with the tightening torque of 0.1 Nm.

- ▶ Tighten the mounting screw using an Allen key.

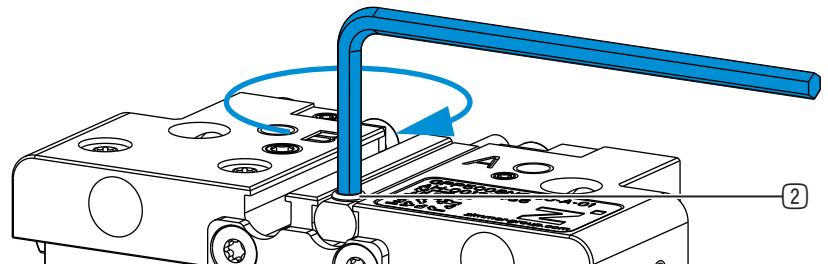

② Mounting screw

8 Commissioning

- ▶ Connect the sensor to the operating voltage.

8.1 Defining switching points

- ▶ Move the piston to the position of the first switching point.
- ▶ Press the teach-in button until the LED display flashes.
- ▶ Release the teach-in button.
 - ⇒ The LED display of the first switching point lights up continuously.
 - ⇒ The first switching point is saved.
 - ⇒ The second LED display flashes.

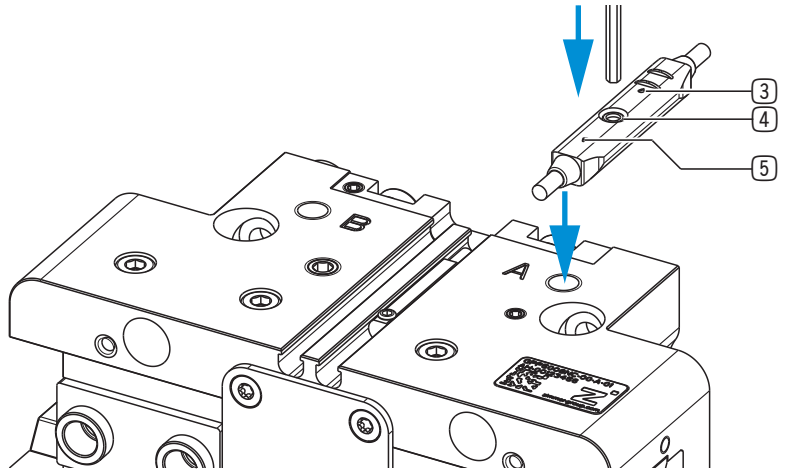

- ▶ Move the piston to the position of the second switching point.
- ▶ Briefly press the teach-in button.
 - ⇒ The second LED display lights up continuously.
 - ⇒ The second switching point is saved.

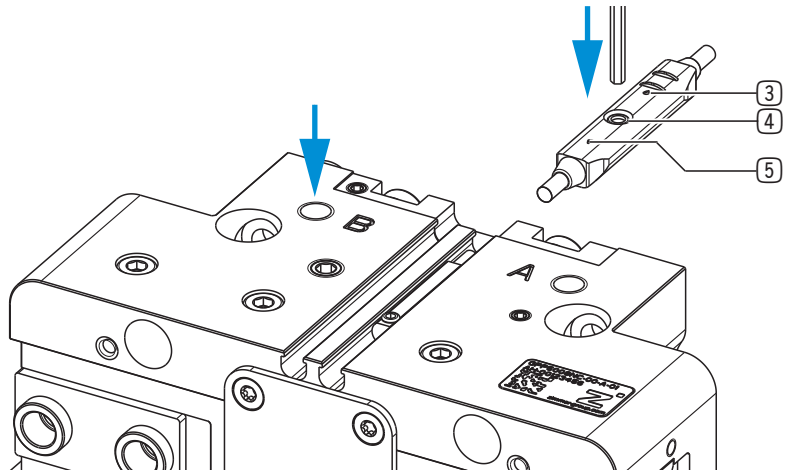

- ③ LED display
- ④ Teach-in button
- ⑤ LED display

8.2 Checking switching points

- ▶ Slide the sensor to the first switching point.
 - ▶ Check whether the LED display for the first switching point lights up.
 - ▶ If the LED display does not light up, check the operating conditions and define the switching point again.
- ▶ Slide the sensor to the second switching point.
 - ▶ Check whether the LED display for the first switching point goes out and the LED display for the second switching point lights up.
 - ▶ If the LED display for the first switching point does not go out or the LED display for the second switching point does not light up, check the operating conditions and define the switching point again.

9 Maintenance

Operation of the product is maintenance-free.

- ▶ Despite the maintenance-free performance mentioned, check the product regularly for secure screw and plug-in connectors.
- ▶ Clean the product if it is dirty.

10 Decommissioning/disposal

INFORMATION



When the product reaches the end of its operational phase, it can be completely disassembled and disposed of.

- ▶ Disconnect the product completely from the power supply.
- ▶ Dispose of the components properly according to the material groups.
- ▶ Comply with the locally applicable environmental and disposal regulations.

11 Declaration of Conformity

In terms of the EU Directive 2014/35/EU (Low voltage directive)

Name and address of the manufacturer:

Zimmer GmbH

Im Salmenkopf
77866 Rheinau, Germany
+49 7844 9138 0
info@zimmer-group.com
www.zimmer-group.com

We hereby declare that the products described below

Product designation: 2-point magnetic field sensor
Type designation: MFS01-K-KHC-P2-PNP
MFS01-S-KHC-P2-PNP
MFS02-K-KHC-P2-PNP
MFS02-S-KHC-P2-PNP

conforms to the requirements of the 2014/35/EC directive in its design and the version we put on the market.

The following harmonized standards have been used:

DIN EN IEC 60947-5-2	Low-voltage switchgear - Part 5-2: Control units and switch elements - proximity switches
DIN EN IEC 63000	Technical documentation for evaluating electrical and electronic equipment regarding the restriction of hazardous substances

A full list of applied standards can be obtained from the manufacturer.

Kurt Ross

Authorized representative for the compilation of relevant technical documents

Rheinau, Germany, 2019-10-31

(Place and date of issuance)

Martin Zimmer
(Legally binding signature)
Managing Partner