



## INSTALLATION AND OPERATING INSTRUCTIONS

2-jaw parallel grippers electric

GEP2000IL-03  
GEP2000IL-43  
DDOC01219

THE KNOW-HOW FACTORY

## Glossary

Term	Explanation
ActualPosition	Value of the current position of the product [1/100 mm]
Adjust	Starts the travel routing stored in the product to teach the BasePosition and WorkPosition.
BasePosition	Outer jaw position Depending on the application, this can be the base position or the work position.
ControlWord	Activation of the product Only one bit is permitted to be active in ControlWord. The value "0" is also permitted.
DeviceMode	Used to select gripping profiles as well as the additional help modes in the product.
Diagnosis	If an error occurs, outputs a diagnostic code that can be compared with the error list.
DIR	Direction/24 V DC cable connection Depending on the product, this signal is used to move the product.
Error	Fault
GND	Abbreviation for ground connection
GripForce	Setting the gripping force
Offset	Correction value
PositionTolerance	Tolerance range for TeachPosition, BasePosition and WorkPosition The value of the parameter acts in both directions.
ShiftPosition	ShiftPosition is a switching position between pre-positioning and gripper movement.
StatusWord	Summary of binary states of the product that can be returned as information to the control system.
Teach	Adoption of the ActualPosition as the TeachPosition.
TeachPosition	Taught-in workpiece position
Traversing routine	Defined procedure for movement of the gripper jaws
Travel path	Path on which the gripper jaws travel.
WorkpieceNo	Number of the selected workpiece recipe
WorkPosition	Inner jaw position Depending on the application, this can be the end position or the work position.
Workpiece loss detection	Function which, in case of workpiece loss, causes the product to move to the end position.

**Content**

- 1 Supporting documents ..... 5
  - 1.1 Notices and graphics in the installation and operating instructions ..... 5
- 2 Safety notices ..... 6
- 3 Proper use ..... 7
- 4 Personnel qualification ..... 7
  - 4.1 Electricians ..... 7
  - 4.2 Specialists ..... 7
  - 4.3 Instructed personnel ..... 7
  - 4.4 Service personnel ..... 7
  - 4.5 Additional qualifications ..... 7
- 5 Product description ..... 8
  - 5.1 Possible applications ..... 8
  - 5.2 Type plate ..... 8
- 6 Functional description ..... 9
  - 6.1 LED status display ..... 10
  - 6.2 Control ..... 10
  - 6.3 Verified configuration examples ..... 10
  - 6.4 Self-locking mechanism ..... 10
- 7 Technical data ..... 11
- 8 Accessories/scope of delivery ..... 11
- 9 Transportation/storage/preservation ..... 11
- 10 Installation ..... 12
  - 10.1 Installing the product ..... 13
  - 10.2 Safe shutoff for products with IO-Link ..... 14
  - 10.3 Installing the energy supply ..... 15
    - 10.3.1 Pin assignment ..... 15
    - 10.3.2 B12-Y-5IL Y-cable pin assignment ..... 16
  - 10.4 Static charge ..... 17
  - 10.5 Heat dissipation ..... 17
  - 10.6 Installing accessories ..... 17
- 11 Commissioning ..... 18
  - 11.1 Process data ..... 18
  - 11.2 IODD Import ..... 19
  - 11.3 Handshake Data Transfer Method ..... 19
  - 11.4 Parameters ..... 20
    - 11.4.1 ControlWord ..... 20
    - 11.4.2 DeviceMode ..... 22
    - 11.4.3 WorkpieceNo ..... 26
    - 11.4.4 PositionTolerance ..... 26
    - 11.4.5 GripForce ..... 27
    - 11.4.6 DriveVelocity ..... 27
    - 11.4.7 BasePosition ..... 28
    - 11.4.8 TeachPosition ..... 28
    - 11.4.9 WorkPosition ..... 28
    - 11.4.10 StatusWord ..... 29
    - 11.4.11 Diagnosis ..... 31
    - 11.4.12 ActualPosition ..... 31
  - 11.5 Minimum travel path ..... 32
  - 11.6 Minimum startup path ..... 32

- 11.7 Easy Startup .....32
- 11.8 Quickstart Basic Parameters .....33
- 11.9 Starting the gripping movement.....34
- 11.10 Repeated movements in the same direction.....34
- 11.11 Recipe examples .....35
  - 11.11.1 Save recipe.....35
  - 11.11.2 Loading a recipe .....36
- 12 Operation..... 37
  - 12.1 Setting the gripping force.....37
  - 12.2 Emergency release .....37
- 13 Gripping force charts..... 37
- 14 Error diagnosis .....38
  - 14.1 Status in LED display for error .....40
- 15 Table with acyclic data (ISDU) ..... 41
- 16 Maintenance..... 43
- 17 Decommissioning/disposal ..... 43
- 18 RoHS declaration..... 44
- 19 REACH declaration..... 44
- 20 Declaration of Incorporation ..... 45
- 21 Declaration of Conformity ..... 46

## 1 Supporting documents

### NOTICE



Read through the installation and operating instructions before installing or working with the product.

The installation and operating instructions contain important notes for your personal safety. They must be read and understood by all persons who work with or handle the product during any phase of the product lifetime.



The documents listed below are available for download on our website [www.zimmer-group.com](http://www.zimmer-group.com).

- Installation and operating instructions
  - Catalogs, drawings, CAD data, performance data
  - Information on accessories
  - Technical data sheets
  - General Terms and Conditions, including warranty information.
- ⇒ Only those documents currently available on the website are valid.

In these installation and operating instructions, "product" refers to the product designation on the title page!

### 1.1 Notices and graphics in the installation and operating instructions

#### DANGER



This notice warns of an imminent danger to the life and health of people. Ignoring these notices can lead to serious injury or even death.

- ▶ You absolutely must comply with the described measures for avoiding these dangers!
- ⇒ The warning symbols are assigned according to the type of danger.

#### WARNING



This notice warns of a situation that is potentially hazardous to personal health. Ignoring these notices can cause serious injury or damage to health.

- ▶ You absolutely must comply with the described measures for avoiding these dangers!
- ⇒ The warning symbols are assigned according to the type of danger.

#### CAUTION



This notice warns of a situation that is potentially hazardous to persons. Ignoring these notices can cause minor, reversible injuries.

- ▶ You absolutely must comply with the described measures for avoiding these dangers!
- ⇒ The warning symbols are assigned according to the type of danger.

#### NOTICE



This notice warns of possible material and environmental damage. Ignoring these notices can result in damage to the product or the environment.

- ▶ You absolutely must comply with the described measures for avoiding these dangers!
- ⇒ The warning symbols are assigned according to the type of danger.

#### INFORMATION



This category contains useful tips for handling the product efficiently. Failure to observe these tips will not result in damage to the product. This information does not include any information relevant to health or workplace safety.

## 2 Safety notices

### CAUTION



#### Risk of injury and material damage in case of non-compliance

Installation, commissioning, maintenance and repairs may only be performed by qualified specialists in accordance with these installation and operating instructions.

The product is state-of-the-art.

It is fitted to industrial machines and is used to hold, transport and store workpieces.

The following are examples of situations in which the product may cause a hazard:

- The product is not properly installed, used or maintained.
- The product is not used for its designated purpose.
- The locally applicable regulations, laws, directives or guidelines are not observed.
- ▶ The product may only be used in accordance with these installation and operating instructions and the product's technical data. Any changes or additions to the intended use of the product, as well as modifications to the product, such as those in the following examples, require the written permission of the manufacturer:
  - Use of the product under extreme conditions, such as aggressive fluids or abrasive dusts
  - Additional drilled holes or threads
- ⇒ Zimmer GmbH shall accept no liability for any damage caused by improper use. The operator bears sole responsibility.
- ▶ Make sure that the power supply is disconnected before you mount, adjust, modify, maintain or repair the product.
- ▶ Whenever work is carried out on the product, make sure that the product cannot be actuated by mistake.
- ▶ Perform maintenance tasks, renovation work or attachment work outside of the machine's danger zone when possible.
- ▶ Do not reach into the operational range of the product.
- ▶ Observe the specified maintenance intervals and specifications regarding the quality of the operating material.
- ▶ When using the product under extreme conditions, adjust the maintenance interval according to the degree of contamination.

### 3 Proper use

#### NOTICE



#### Material damage and malfunction in case of non-compliance

The product is only to be used in its original state with its original accessories, with no unauthorized changes and within the stipulated parameter limits and operating conditions.

Any other or secondary use is deemed improper.

- ▶ Operate the product only in compliance with the associated installation and operating instructions.
  - ▶ Operate the product only when it is in a technical condition that corresponds to the guaranteed parameters and operating conditions.
- ⇒ Zimmer GmbH shall accept no liability for any damage caused by improper use. The operator bears sole responsibility.

- The product is designed exclusively for electric operation using a 24 V DC power supply.
- The product must always be mounted on materials that dissipate heat.
- The product is intended for industrial use.
- The product is to be used as intended in enclosed rooms for temporary gripping, handling and holding.
- The product is not suitable for clamping workpieces during a machining process.
- Direct contact with perishable goods/food is not permitted.
- Observance of the technical data and of the installation and operating instructions are part of proper use.

### 4 Personnel qualification

#### WARNING



#### Injuries and material damage due to inadequate qualification

If inadequately qualified personnel perform work on the product, this can cause serious injuries and significant material damage.

- ▶ All work on the product must be performed by qualified personnel.
- ▶ Before working with the product, read the document in its entirety and make sure that you have understood everything.
- ▶ Observe country-specific accident prevention regulations and the general safety notices.

The following qualifications are a prerequisite for performing various work on the product.

#### 4.1 Electricians

Electricians are able to perform work on electrical systems, can recognize and avoid possible dangers and know the relevant standards and provisions due to their technical training, knowledge and experience.

#### 4.2 Specialists

Specialists are able to perform the assigned work, can recognize and avoid possible dangers and know the relevant standards and provisions due to their technical training, knowledge and experience.

#### 4.3 Instructed personnel

Instructed personnel have been trained by the operating company on the tasks and possible dangers of improper behavior.

#### 4.4 Service personnel

Service personnel are able to perform the assigned work and can recognize and avoid possible dangers due to their technical training, knowledge and experience.

#### 4.5 Additional qualifications

Persons who work with the product must be familiar with the valid safety regulations and laws as well as the standards, guidelines and laws listed in this document.

Personnel who work with the product must have facility-issued authorization to commission, program, configure, operate, maintain and also decommission this product.

## 5 Product description

### CAUTION



**Reduction of the gripping force can cause personal injury and material damage**

When flexible components are gripped, the gripping force of the product is reduced.

Reduced gripping force can lead to personal injury or material damage, because the components that are being gripped can no longer be securely gripped and transported.

### NOTICE



► Make sure that the setting of the gripping force and the selection of the gripper finger length are correct to prevent incorrect bracing of the gripper jaws.

⇒ An incorrect configuration or selection can lead to malfunction

### 5.1 Possible applications

#### Outside gripping

The product can be used for outside gripping.

MoveToWork command

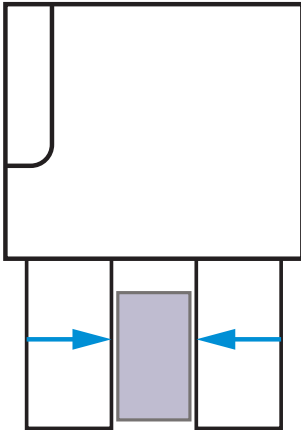

#### Inside gripping

The product can be used for inside gripping.

MoveToBase command

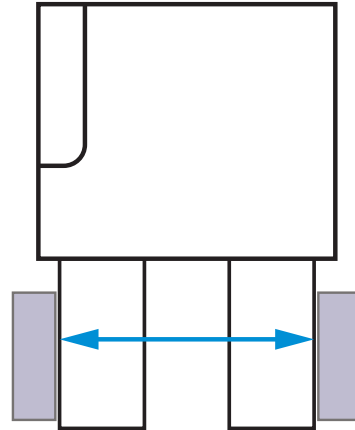

### 5.2 Type plate

A type plate is attached to the housing of the product.

The article number and confirmation number are shown on the type plate.

① Article number

② Confirmation number

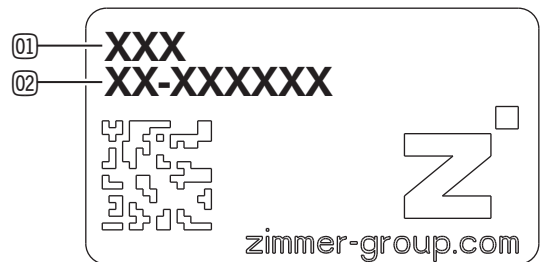



## 6 Functional description

The gripper jaws of the product are arranged parallel to each other on two opposing guide rails and can be moved relative to each other.

The force of the motor is transmitted by a worm drive. A pinion and a rack generate the movement of the gripper jaws and synchronize these movements.

Despite its small installation space, the product is suited for gripping a wide range of form-fit and frictional fit parts.

You can optionally adjust the gripping force to the workpiece by using the control system via IO-Link.

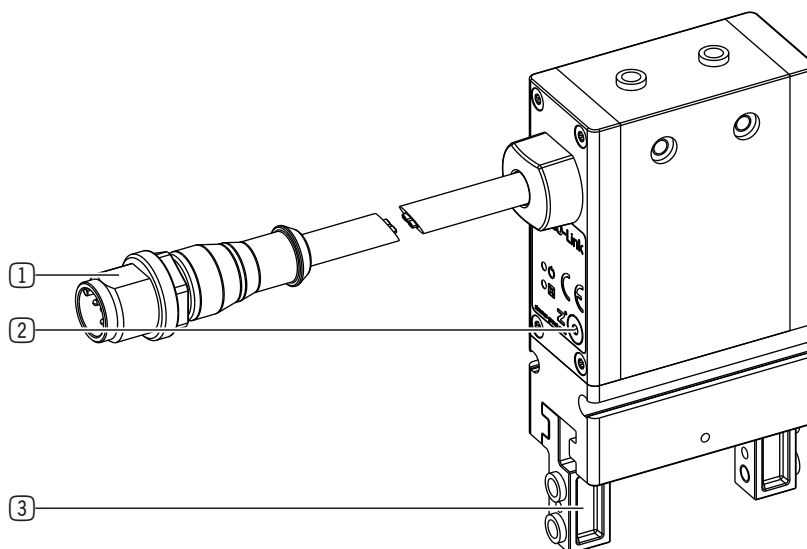

- ① Power supply
- ② Emergency release
- ③ Gripper jaw

## 6.1 LED status display

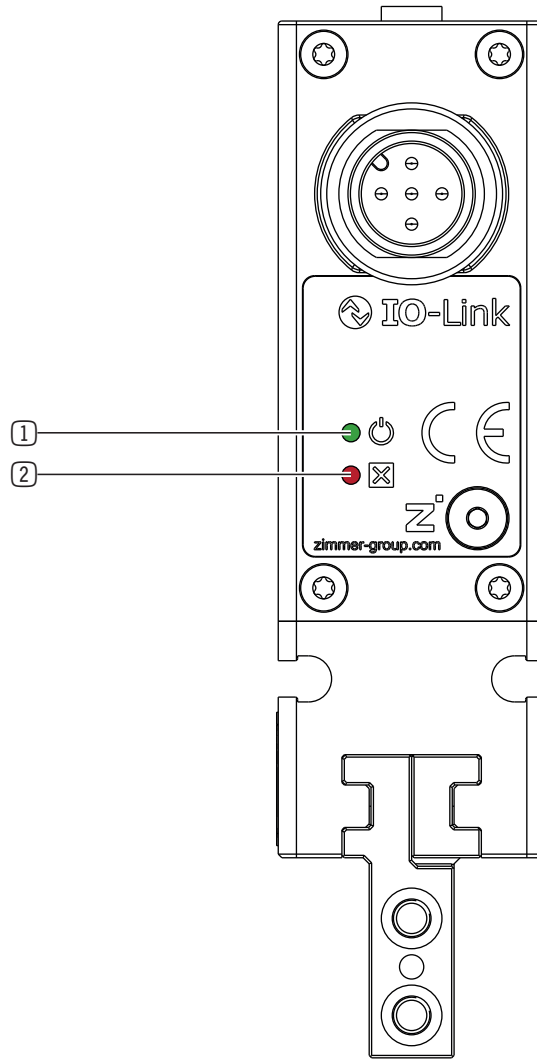

- ① Power/communication
- ② Error

## 6.2 Control

### INFORMATION



- ▶ You can find the information in the technical data sheet on our website.
- ▶ Please contact Customer Service if you have any questions.

## 6.3 Verified configuration examples

### INFORMATION



- ▶ You can find the information in the technical data sheet on our website.
- ▶ Please contact Customer Service if you have any questions.

## 6.4 Self-locking mechanism

### INFORMATION



- The product has a mechanical self-locking mechanism to ensure that the workpiece remains held by the product in the event of power supply loss or failure (e.g. an emergency stop).
- ▶ Please contact Customer Service if you have any questions.

## 7 Technical data

### INFORMATION



- ▶ You can find the information in the technical data sheet on our website.
- This data varies within the series, depending on the specific design.
- ▶ Please contact Customer Service if you have any questions.

## 8 Accessories/scope of delivery

### INFORMATION



- If any accessories not sold or authorized by Zimmer GmbH are used, the function of the product cannot be guaranteed. Zimmer GmbH accessories are specifically tailored to the individual products.
- ▶ For optional accessories and those included in the scope of delivery, refer to our website.

## 9 Transportation/storage/preservation

- ▶ Transport and storage of the product must be done only with the original packaging.
- ▶ If the product has already been installed on the superordinate machine unit, care must be taken during transport to ensure that no unexpected movements can occur.
  - ▶ Before commissioning the product and after transport, check all power and communication connections as well as all mechanical connections.
- ▶ If the product is stored for an extended period, the following points are to be observed:
  - ▶ Keep the storage location as dust-free and dry as possible.
  - ▶ Avoid temperature fluctuations.
  - ▶ Avoid wind/drafts/water condensation formation.
  - ▶ Pack the product and do not expose it to direct sunlight during storage.
- ▶ Clean all components. There must be no soiling left on the components.
- ▶ Visually inspect all components.
- ▶ Remove all foreign substances.
- ▶ Properly remove potential corrosion spots.
- ▶ Close electrical connections using suitable covers.

## 10 Installation

### WARNING



#### Risk of injury due to uncontrolled movements

Risk of injury in case of unexpected movement of the machine or system into which the product is to be installed.

- ▶ Switch off the energy supply of the machine before any work.
- ▶ Secure the power supply against being switched on unintentionally.
- ▶ Check the machine for any residual energy that may be present.

### CAUTION



#### Risk of injury due to uncontrolled movements

Risk of injury in the event of uncontrolled movement of the product when the power supply is connected.

- ▶ Switch off the power supply to the machine before carrying out any work.
- ▶ Secure the power supply against being switched on unintentionally.
- ▶ Check the machine for any residual energy that may be present.

### NOTICE



Installation may only be carried out by qualified personnel in accordance with these installation and operating instructions.

- ▶ Switch off the power supply before any assembly, installation or maintenance work.

### INFORMATION



Requirements for the mounting surface:

- Permissible unevenness [mm]: 0.03
- Cleanliness of the mounting surfaces of the product and mounting piece (product grounding)

Further installation information:

- The mounting screws are not included in the scope of delivery.
- Strength class of the mounting screws is at least 8.8 (DIN EN ISO 4762)

- ▶ Install the product on an appropriate mounting surface in accordance with the flatness specifications.
- ▶ Make sure that the mounting piece is sufficiently rigid.
- ▶ Please note the permitted tightening torques of the mounting screws at [www.zimmer-group.com/de/td](http://www.zimmer-group.com/de/td).

### 10.1 Installing the product

The product can be installed from multiple sides.

- ▶ Insert the centering sleeves into the provided fits on the product.
- ▶ Position the product on the mounting piece using centering sleeves.
- ▶ Mount the product on the mounting piece using the appropriate mounting screws.

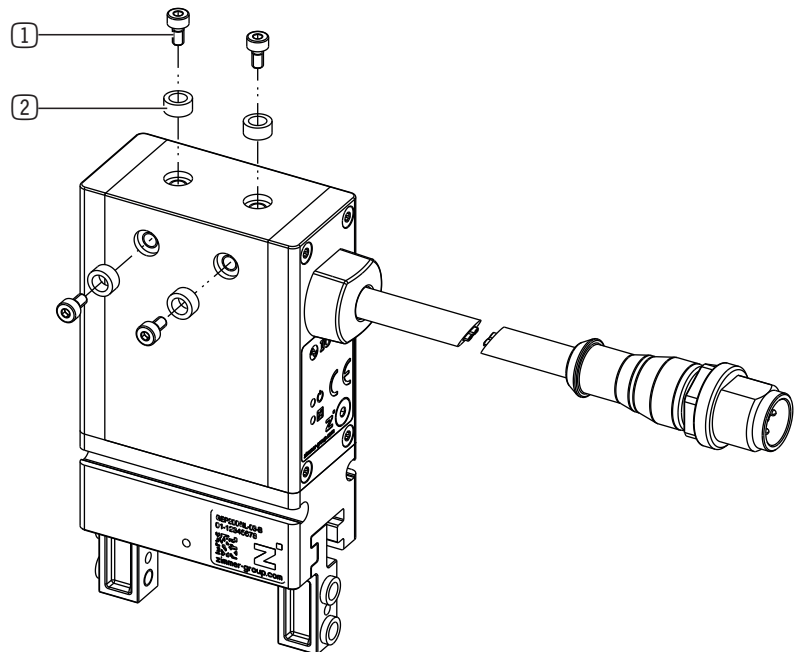

- ① Mounting screw
- ② Centering Disc

#### INFORMATION



- ▶ Use an adapter plate if necessary.
- ▶ For information on optional accessories and those included in the scope of delivery, refer to our website.

10.2 Safe shutoff for products with IO-Link

INFORMATION



For safe shutoff for IO-Link products, two contactors are switched in series with one auxiliary contact each. Here, the auxiliary contacts monitor the status of the contactors. If one contactor does not switch, the second contactor ensures safety. The malfunction can still be detected using the contacts.

The following figure shows the example of a circuit through which the IO-Link master cannot conduct the load current of the product.

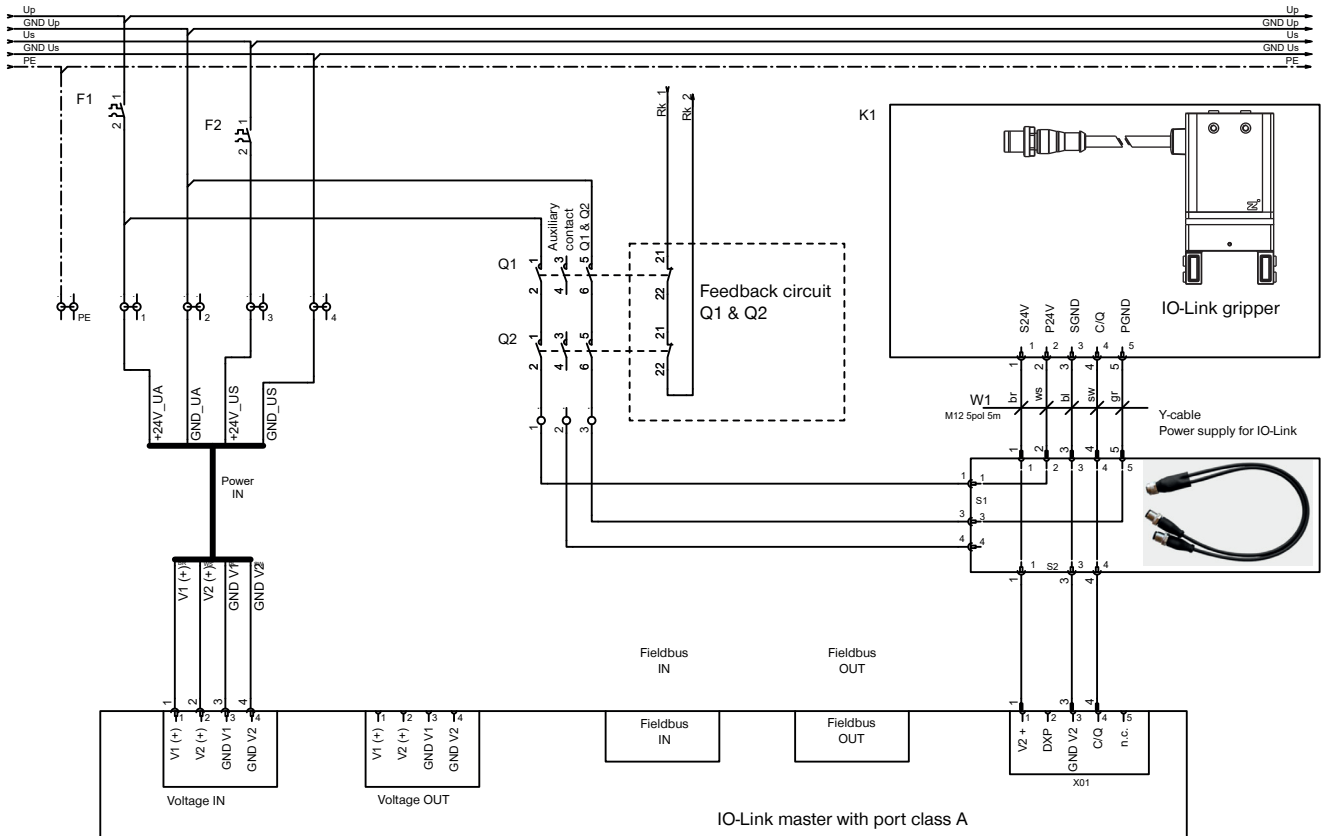

NOTICE



Without an externally fed voltage supply, the motor of the product cannot carry out an active movement and thus cannot carry out a hazardous movement.

There is no galvanic separation between the two voltage supplies (signal and power). There is a low-voltage connection via the ground (GND).

Because of the self-locking mechanism, the product remains in the last approached position, even if no voltage is supplied.

### 10.3 Installing the energy supply

#### CAUTION



**Non-compliance may result in material damage.**

- Incorrect pin assignment can lead to malfunction or destruction of the product.
- ▶ Be absolutely certain to ensure correct pin assignment.

#### NOTICE



**Non-compliance may result in material damage.**

The cable mounted on the product can be subjected to a torsional angle of +50°.

- ▶ Do not route the cable so that it is strained.
  - ▶ You must meet the minimum bending radius of 10x the outer diameter.
  - ▶ Secure free-hanging cables to prevent excessive motion loads or pinching.
  - ▶ The contacts of the energy supply must be dry, clean and undamaged at all times.
- ⇒ Damage to the contacts can result in malfunction of the product.

- ▶ Connect the power supply cable to the control system of the product.

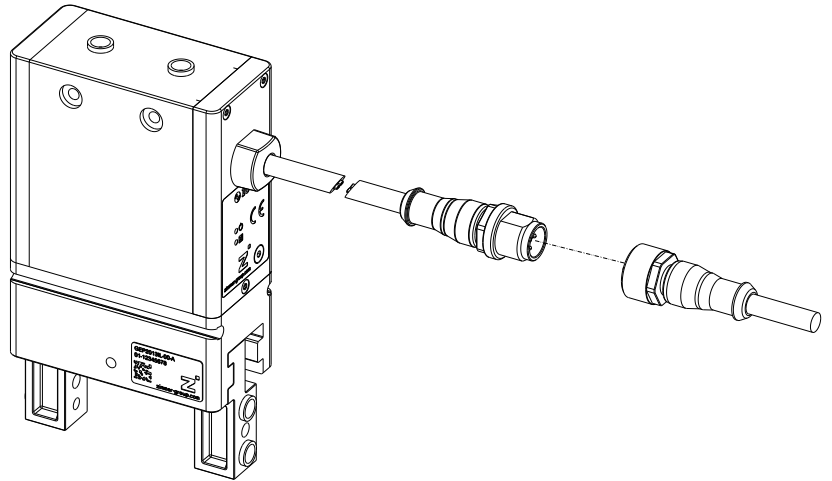

#### 10.3.1 Pin assignment

#### INFORMATION



- ▶ Note the deviation from the IO-Link port class B specification: There is no electrical isolation between the actuator and sensor voltage in the product.

⇒ An optional B12 Y-cable allows electrical isolation from the perspective of the IO-Link master.

pin	Color	Function	Explanation
1	Brown	24 V DC sensor	24 V DC supply voltage for IO-Link communication
2	White	PWR actuator	24 V DC supply voltage for actuator
3	Blue	GND sensor	0 V DC supply voltage for IO-Link communication
4	Black	C/Q	IO-Link communication
5	Gray	GND actuator	0 V DC actuator supply voltage

M12 5-pin plug

- ▶ Connect the product to the IO-Link master.
- ▶ Ensure the proper voltage supply.

10.3.2 B12-Y-5IL Y-cable pin assignment

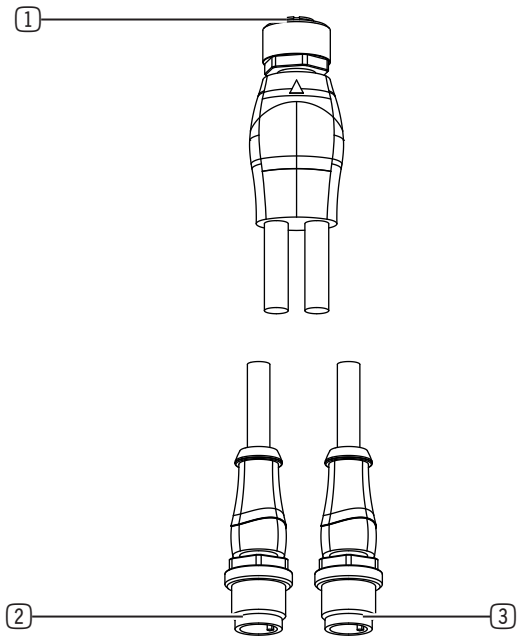

- ① Socket
- ② Plug 1
- ③ Plug 2

pin	Color	Function	Explanation
1	Brown	24 V DC sensor	24 V DC supply voltage for IO-Link communication
2	White	PWR actuator	24 V DC supply voltage for actuator
3	Blue	GND sensor	0 V DC supply voltage for IO-Link communication
4	Black	C/Q	IO-Link communication
5	Gray	GND actuator	0 V DC supply voltage for actuator

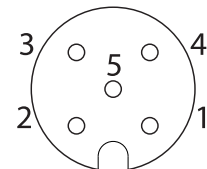

M12 5-pin socket

pin	Color	Function	Explanation
1	Brown	-	-
2	White	PWR actuator	24 V DC supply voltage for actuator
3	Blue	-	-
4	Black	-	-
5	Gray	GND actuator	0 V DC supply voltage for actuator

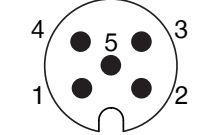

M12 5-pin plug 1

pin	Color	Function	Explanation
1	Brown	24 V DC sensor	24 V DC supply voltage for IO-Link communication
2	White	-	-
3	Blue	GND sensor	0 V DC supply voltage for IO-Link communication
4	Black	C/Q	IO-Link communication
5	Gray	-	-

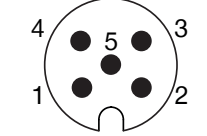

M12 5-pin plug 2



## 10.4 Static charge

### CAUTION



#### Material damage from static charge

Material damage can result from contact of ESD-sensitive parts with the product.

- ▶ It is mandatory to ground the gripper fingers.

Grounding is also recommended in applications that require high EMC shielding.

The movement of the gripper jaws creates low voltages as a result of static charging. These charges cannot be dissipated if the product is mounted on an insulating surface and if discharge is also not possible through the workpiece.

## 10.5 Heat dissipation

In the event of high ambient temperatures, the product must be installed on heat-dissipating materials.

If the product is operated under very high ambient temperatures and with fast clock cycles on an ongoing basis, this might reduce its service life.

### INFORMATION



- ▶ The cycle time must therefore be reduced as the temperature increases.

## 10.6 Installing accessories

### NOTICE



- ▶ Before installing an accessory, make sure it is suitable for use with the selected variant.
- ▶ You can find information on our website.
- ▶ Please contact Customer Service if you have any questions.

## 11 Commissioning

### 11.1 Process data

There is an option to control the product only with the process data that is transmitted in each cycle.

#### INFORMATION



The terms process data input and output are to be understood from the perspective of the gripper.

Name	Data type
ControlWord	UINT16
DeviceMode	UINT8
WorkpieceNo	UINT8
Reserve	UINT8
PositionTolerance	UINT8
GripForce	UINT8
DriveVelocity	UINT8
BasePosition	UINT16
Reserve	UINT16
TeachPosition	UINT16
WorkPosition	UINT16

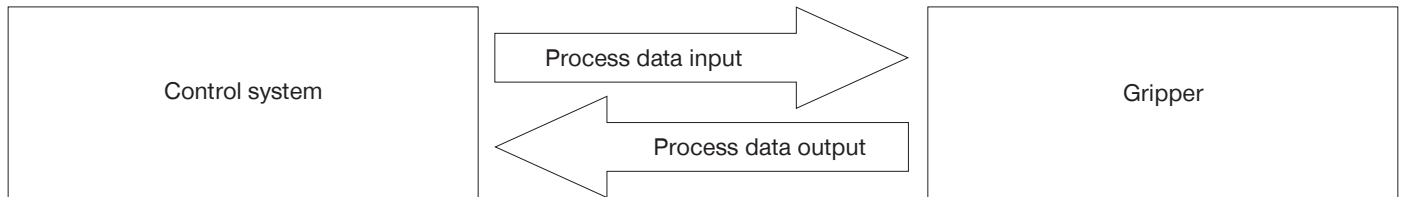

Name	Data type
StatusWord	UINT16
Diagnosis	UINT16
ActualPosition	UINT16

## 11.2 IODD Import

- ▶ Import the IODD (device description) into the control system.
  - ▶ Go to our website.
  - ▶ Select the desired product.
  - ▶ Download the corresponding .zip file via the Download IODD link.
- ⇒ You will need the .zip file for import into the control system.
- ⇒ As soon as the hardware configuration is complete and the IO-Link connection to the product is established, data will be displayed in the process input data.
- ⇒ Some control systems demand a byte swap to bring this process data into a logical sequence.
- ▶ Look at bit 6 (GripperPLCActive) in the StatusWord to determine whether a byte swap is necessary.
  - ▶ Determine whether bit 6 is active in the first or second byte of the StatusWord.
    - ⇒ Bit 6 is active in the first byte: The bytes already have the correct sequence.
      - ▶ Continue with the commissioning.
    - ⇒ Bit 6 is active in the second byte.
      - ▶ Apply a byte swap, refer to the "StatusWord" section.

### INFORMATION



The product is controlled via IO-Link by means of the cyclical process data as well as the acyclic service data with a cycle time of 5 ms.

- ▶ It is mandatory to verify the process data!

## 11.3 Handshake Data Transfer Method

The handshake method makes it possible to transfer the process data about the product. All process data described in the following sections must be transferred with the handshake.

- ▶ Send the ControlWord = 0x0001 to the product.
- ⇒ The data transfer was started.
- ▶ Check the response of the product by using Statusbit 12 = TRUE (data transfer OK).
- ▶ Send the ControlWord = 0x0000 to stop the data transfer.
- ⇒ The data transmission is complete when the product sends back Statusbit 12 = DataTransferOK = FALSE.

### INFORMATION



- ▶ For examples, refer to the "Quickstart Basic Parameters" section.

## 11.4 Parameters

### 11.4.1 ControlWord

#### NOTICE



In the ControlWord parameter, only one single bit or the value 0 may be set at a time. Only the values listed in the following table are valid.

Parameter	Decimal value	Hexadecimal value
DataTransfer	1	0x0001
WritePDU	2	0x0002
ResetDirectionFlag	4	0x0004
Teach	8	0x0008
MoveToBase	256	0x0100
MoveToWork	512	0x0200
JogToWork +	1024	0x0400
JogToBase -	2048	0x0800
ErrorReset	32768	0x8000

Name	ControlWord
Data format	UINT16
Permission	Write
Transfer	Cyclical
Value range	0 - 65535

	Bit 15	Bit 14	Bit 13	Bit 12	Bit 11	Bit 10	Bit 9	Bit 8
Byte 1	ErrorReset	-	-	-	JogToBase	JogToWork	MoveToWork	MoveToBase
	Bit 7	Bit 6	Bit 5	Bit 4	Bit 3	Bit 2	Bit 1	Bit 0
Byte 2	-	-	-	-	Teach	ResetDirectionFlag	WritePDU	DataTransfer

#### Bit 0: DataTransfer

Setting this bit causes the product to acquire the data transmitted in the process data ("WorkpieceNo" = 0) or the data stored in the workpiece data ("WorkpieceNo" = 1 to 32) as the active data set.

Setting this bit tells the product that the direction flag needs to be reset. This function is available starting from Application Firmware Version SWA000170\_A00, see Chapter "Table of acyclic data (ISDU)" Index 0x0017.

#### Bit 1: WritePDU

Setting this bit tells the product that it should write the current process data to the selected workpiece recipe.

**Bit 2: ResetDirectionFlag**

Setting this bit tells the product that the direction flag needs to be reset. This makes a repeated movement to a position possible. This is logical during a switchover of workpiece recipes.

**NOTICE**

- ▶ Please note that the product can be damaged from overheating due to repeated, prompt movement to the end stop or with a gripped workpiece.

**Bit 3: Teach**

Setting this bit tells the product to save the current position as the TeachPosition in the selected WorkpieceNo. This only works if there is no "0" that is transmitted in the workpiece number.

**Bit 8: MoveToBase**

Setting this bit tells the product to move toward the BasePosition.

**Bit 9: MoveToWork**

Setting this bit tells the product to move toward the WorkPosition.

**Bit 10: JogToWork**

Setting this bit in the ControlWord puts the product in jog mode and slowly moves it toward the WorkPosition. If the bit is reset, the product stops.

**Bit 11: JogToBase**

Setting this bit in the ControlWord puts the product in jog mode and slowly moves it toward the BasePosition. If the bit is reset, the product stops.

**Bit 15: ErrorReset**

This bit can be used to acknowledge all errors that can be reset. Whether an error can be reset is shown in the "Error Diagnosis" section.

### 11.4.2 DeviceMode

#### INFORMATION



DeviceMode is used to select one of the following travel modes: universal operation, outside gripping or inside gripping. Zimmer GmbH recommends DeviceMode 63, 73 and 103.

Input	Mode	Description
63	Outside gripping with subsequent current feed	Like Mode 60, but with an activated subsequent current feed for a time of 500 ms when the direction of movement is Work. To achieve the best gripping results, the gripped workpiece must be transported further during the subsequent current feed.
73	Inside gripping with subsequent current feed	Like Mode 70, but with an activated subsequent current feed for a time of 500 ms when the direction of movement is Base. To achieve the best gripping results, the gripped workpiece must be transported further during the subsequent current feed.
103	Universal operation with subsequent current feed	Like Mode 100, but with an activated subsequent current feed for a time of 500 ms in both directions. To achieve the best gripping results, the gripped workpiece must be transported further during the subsequent current feed.
11	Activate jog mode.	Product is in jog mode and moves slowly in the selected direction as long as the respective bit is active in the ControlWord.
< 50	Positioning mode	Product moves in the PositionProfile. The movement speed is configured using the DriveVelocity parameter.
60	Outside gripping	Inward with the desired gripping force, outward with the desired speed.
70	Inside gripping	Outward with the desired gripping force, inward with the desired speed.
100	Universal mode	Inside and outside gripping, both movements at the same speed depending on the desired gripping force.

Name	DeviceMode
Data format	UINT8
Permission	Write
Transfer	Cyclical
Value range	11, 50, 60, 63, 70, 73, 100, 103

### 11.4.2.1 PositionProfile

This mode can be used for positioning the product or for form-fit gripping.

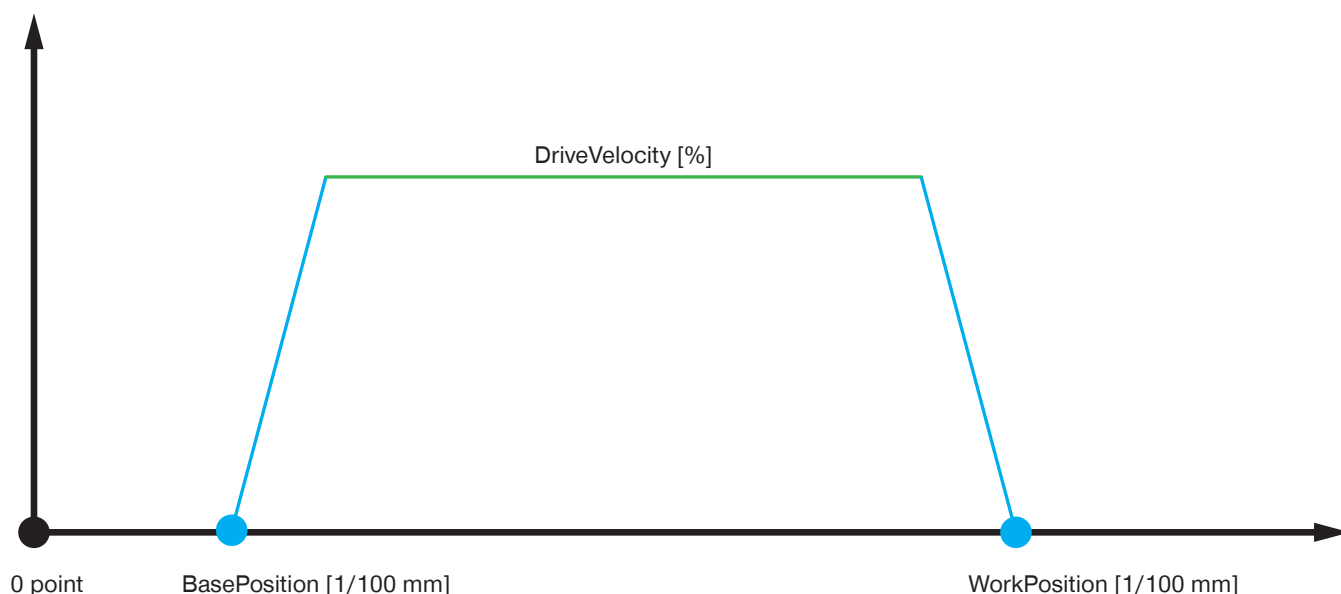

Parameter	Description
BasePosition	Open position
WorkPosition	Closed position
GripForce	Not used
TeachPosition	Not used
PositionTolerance	Not used
DriveVelocity	Movement speed

The movement speed is configured using the DriveVelocity parameter.

The TeachPosition does not have any significance in this mode, because the BasePosition or WorkPosition is always approached precisely.

If the product encounters an obstacle in this mode while moving, it stops and issues an error message.

The product can be moved from the obstacle back to the starting position if the command is switched in the ControlWord.

No defined gripping forces can be generated in this mode. As a result, friction-locked gripping is not permitted in this mode.

### 11.4.2.2 ForceProfile

This mode can be used for frictional fit gripping.

The gripping force is built up by the movement speed of the jaws and the motor current. When gripping a workpiece, an independent mechanical locking system in the mechanical system is reached that makes it possible to hold the workpiece de-energized.

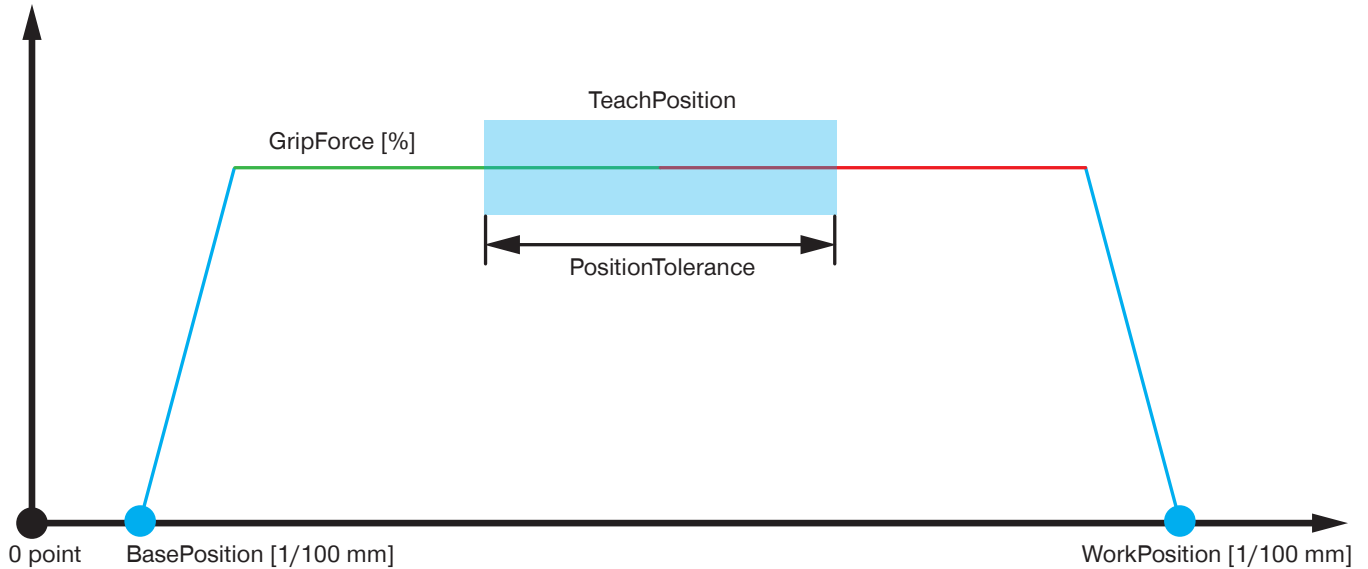

Parameter	Description
BasePosition	Open position
WorkPosition	Closed position - behind the workpiece
GripForce	Desired gripping force
TeachPosition	Expected position of the workpiece
PositionTolerance	Permitted tolerance for the workpiece
DriveVelocity	Opening speed

Since gripping should occur in one direction only, the positioning mode is used automatically in the opposite direction. To do this, the product switches into positioning mode automatically when moving in the opening direction.

The movement profile determines the direction in which the workpiece is gripped:

- Outside gripping: Movement profile group 60
- Inside gripping: Movement profile group 70



**NOTICE**



The product begins the braking process shortly before reaching the desired position in order to be able to position itself exactly at the set WorkPosition and BasePosition.

Braking ahead of the target position can be deactivated using the following parameters in order ensure that full gripping force is reached:

DeviceMode	Parameters for disabling the braking ramp
60, 63 (outside gripping)	WorkPosition = max. position, see "WorkPosition Parameter" section
70, 73 (inside gripping)	BasePosition = 0

**Mode Group 60 – typically used for outside gripping**

DeviceMode	Action	ControlWord
63	Move toward the WorkPosition until this position or the workpiece is reached.	0x0200
63	Move toward the BasePosition to open the product.	0x0100

**Mode Group 70 – typically used for inside gripping**

DeviceMode	Action	ControlWord
73	Move toward the BasePosition until this position or the workpiece is reached.	0x0100
73	Move toward the WorkPosition for opening the product.	0x0200

**11.4.2.3 Current feed profile for a gripping process with DeviceMode 63, 73, 103**

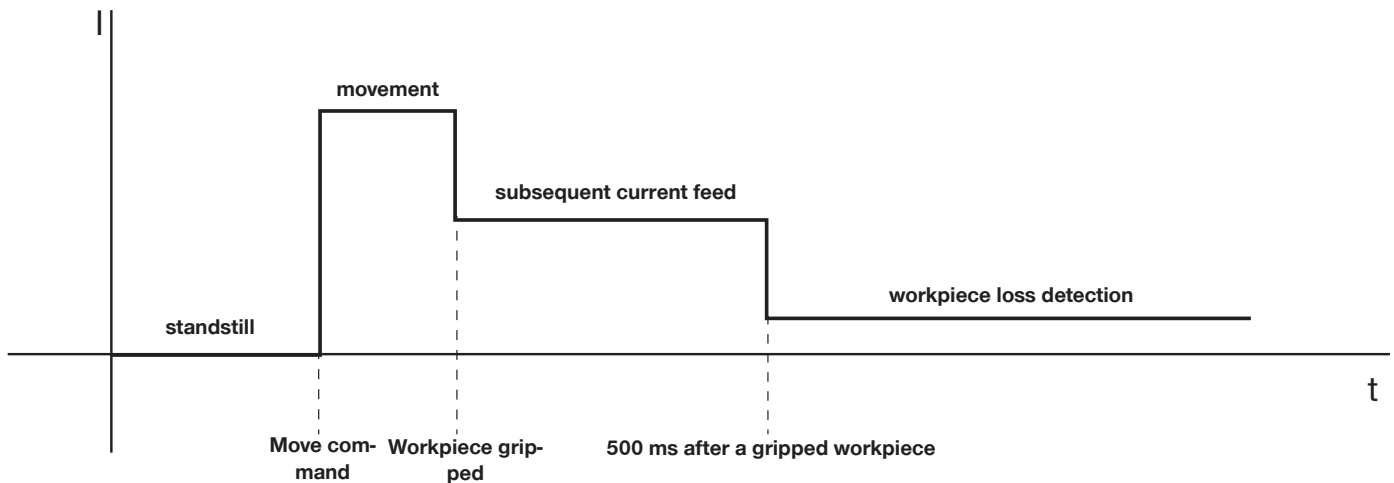

**NOTICE**



In case of workpiece loss, the product moves to the end position and outputs a message.

### 11.4.3 WorkpieceNo

The workpiece number is used for selecting the previously stored workpiece data, as well as for selecting the WorkpieceNo data record in which the current process data is stored.

WorkpieceNo enables individual workpieces to be taught in to the product very quickly if the recipes are not managed on the control system.

#### INFORMATION



For example codes, refer to the "Quickstart Basic Parameters" and "Recipe Examples" sections.

Name	WorkpieceNo
Data format	UINT8
Permission	Write
Transfer	Cyclical
Value range	0 - 32

At a value > 0, the corresponding workpiece recipe is loaded in the product.

### 11.4.4 PositionTolerance

Used to configure the position tolerance with a resolution of 0.01 mm.

Thus, the value range of 0 to 255 can be used to set a maximum tolerance of 2.55 mm in both directions.

#### INFORMATION



Example:

For TeachPosition 1500 (15 mm), PositionTolerance 150 lets you configure a tolerance of 1.5 mm in both directions.

This means that the TeachPosition range starts at 13.5 mm and goes all the way up to 16.5 mm.

Name	PositionTolerance
Data format	UINT8
Permission	Write
Transfer	Cyclical
Value range	0 to 255

### 11.4.5 GripForce

The product can use various gripping forces and gripping speeds to achieve an optimized flow of the gripping process. Since the product generates gripping force from the gripping speed and the amperage, the gripping force setting also conversely influences the gripping speed and amperage. The gripping force can be adjusted in four stages.

#### INFORMATION



- ▶ For the values for the gripping force, refer to the technical data sheet on our website.
- This data varies within the series, depending on the specific design.
- ▶ Please contact Customer Service if you have any questions.

Name	GripForce	
Data format	UINT8	
Permission	Write	
Transfer	Cyclical	
Value range	1	Level 1
	2	Level 2
	3	Level 3
	4	Level 4

### 11.4.6 DriveVelocity

The product can work at various movement speeds for an optimized process sequence. This parameter determines the movement speed of the product in both directions in PositionProfile. In the other modes, this parameter determines the movement speed from the workpiece.

#### INFORMATION



- ▶ For the values for the speed, refer to the technical data sheet on our website.
- This data varies within the series, depending on the specific design.
- ▶ Please contact Customer Service if you have any questions.

Name	DriveVelocity	
Data format	UINT8	
Permission	Write	
Transfer	Cyclical	
Value range	1	Level 1
	2	Level 2
	3	Level 3
	4	Level 4

### 11.4.7 BasePosition

The BasePosition defines the target position in the MoveToBase direction. It must always be less than the WorkPosition. The product verifies this and, if necessary, displays an error message.

If the current position of the product within the tolerance range is in the vicinity of the BasePosition, bit 8 is set in the StatusWord.

Name	BasePosition
Data format	UINT16
Permission	Write
Transfer	Cyclical
Value range	0 to WorkPosition

### 11.4.8 TeachPosition

The TeachPosition notifies the product of the expected position of the workpiece. The tolerance range around the expected position of the workpiece is defined using the PositionTolerance. The StatusWord notifies the control system of whether the desired workpiece has been gripped. The user can monitor this work step with the Teach bit.

► Use the following values:

Product	BasePosition	WorkPosition	TeachPosition
GEP2006IL-03	0	1200	0 to max. 1200
GEP2006IL-43	0	2000	0 to max. 2000
GEP2010IL-03	0	2000	0 to max. 2000
GEP2010IL-43	0	2600	0 to max. 2600
GEP2013IL-03	0	2600	0 to max. 2600
GEP2013IL-43	0	3200	0 to max. 3200
GEP2016IL-03	0	3200	0 to max. 3200
GEP2016IL-43	0	4000	0 to max. 4000

Name	TeachPosition
Data format	UINT16
Permission	Write
Transfer	Cyclical
Value range	0 to max. jaw stroke of the product

### 11.4.9 WorkPosition

The WorkPosition defines the maximum travel path of the product and has to be greater than the BasePosition.

Name	WorkPosition
Data format	UINT16
Permission	Write
Transfer	Cyclical
Value range	BasePosition to max. jaw stroke of the product

### 11.4.10 StatusWord

StatusWord structure:

	Bit 15	Bit 14	Bit 13	Bit 12	Bit 11	Bit 10	Bit 9	Bit 8
Byte 1	Error	ControlWord 0x0200	ControlWord 0x0100	DataTransferOK	Undefined- Position	WorkPo- sition	TeachPo- sition	BasePo- sition
	Bit 7	Bit 6	Bit 5	Bit 4	Bit 3	Bit 2	Bit 1	Bit 0
Byte 2	-	Gripper- PLCActive	JogWork- Active +	JogBase- Active -	Movement- Complete	InMotion	MotorON	HomingPo- sition OK

#### Bit 0: HomingPosition OK

The product is calibrated at the factory and does not have to be referenced by the customer.

#### Bit 1: MotorON

The motor of the product switches on automatically when there is a move command. The customer cannot switch it on/off manually.

#### Bit 2: InMotion

This bit is active during the run.

#### Bit 3: MovementComplete

This bit is active after the movement is complete.

#### Bit 4: JogBaseActive -

Confirmation during the Jog run in the direction of BasePosition.

#### Bit 5: JogWorkActive +

Confirmation during the Jog run in the direction of WorkPosition.

#### Bit 6: GripperPLCActive

Active as soon as the product has booted up after the cold boot. This bit can be used to verify a "byte swap."

#### Bit 8: BasePosition

Active if the product is set to BasePosition.

#### Bit 9: TeachPosition

Active if the product is set to TeachPosition.

#### Bit 10: WorkPosition

Active if the product is set to WorkPosition.

**Bit 11: UndefinedPosition**

Active if the product is not set to TeachPosition, WorkPosition or BasePosition.

**Bit 12: DataTransferOK**

This bit is used for data transmission using the handshake. Active as soon as the product has taken over the data using the parameter ControlWord = 1 (decimal).

**Bit 13: ControlWord 0x0100**

This bit is a direction flag. Active if the last motion task was carried out toward BasePosition.

**Bit 14: ControlWord 0x0200**

This bit is a direction flag. Active if the last motion task was carried out toward WorkPosition.

**Bit 15: Error**

Active if the product has an active error. The error message can be determined using Diagnosis.

Name	StatusWord
Data format	UINT16
Permission	Read
Transfer	Cyclical
Value range	0 - 65535

**11.4.10.1 Acknowledging an error**

If the product has a fault, the error bit is set in the status word.

- ▶ Acknowledge the error by sending ControlWord 0x8000.

**NOTICE**



Not all errors can be reset. For some errors, the error message is not reset after acknowledgment.

In this case, wait until correct values are sent to the product.

Example: Overheating error

**INFORMATION**



- ▶ Use StatusWord to verify correct gripping.
- ▶ The TeachPosition tolerance can be adjusted in another process parameter.
- ▶ For sensing the correct position via the ACTUAL position, the tolerances and fluctuations of the value must be observed during programming.

### 11.4.11 Diagnosis

The value returned in Diagnosis corresponds to the error code (see "Error Diagnosis" section).

Name	Diagnosis
Data format	UINT16
Permission	Read
Transfer	Cyclical
Value range	0 - 65535

### 11.4.12 ActualPosition

ActualPosition corresponds to the current position of the gripper jaws relative to the full stroke.

The value is specified with a resolution of 0.01 mm.

The values can move between the BasePosition (minimum values) and the WorkPosition (maximum values).

Product	BasePosition	WorkPosition	TeachPosition	Accuracy [mm]
GEP2006IL-03	0	1200	0 to max. 1200	± 0.05
GEP2006IL-43	0	2000	0 to max. 2000	± 0.05
GEP2010IL-03	0	2000	0 to max. 2000	± 0.05
GEP2010IL-43	0	2600	0 to max. 2600	± 0.05
GEP2013IL-03	0	2600	0 to max. 2600	± 0.1
GEP2013IL-43	0	3200	0 to max. 3200	± 0.1
GEP2016IL-03	0	3200	0 to max. 3200	± 0.1
GEP2016IL-43	0	4000	0 to max. 4000	± 0.1

Name	ActualPosition
Data format	UINT16
Permission	Read
Transfer	Cyclical
Value range	0 to max. jaw stroke of the product

### INFORMATION



- ▶ Use the StatusWord of the product to check whether a workpiece has been gripped correctly.
  - The position measurement resolution is 0.01 mm.
  - The accuracy of the position measurement depends on the installation size.
- ▶ During commissioning, be aware of fluctuations around the exact value if you use the ActualPosition parameter to detect the workpiece.

### 11.5 Minimum travel path

The product requires a certain minimum travel path to move to the desired position.

Design size	Minimum travel path per gripper jaw [mm]
GEP2006IL-03	1
GEP2006IL-43	1
GEP2010IL-03	1
GEP2010IL-43	1
GEP2013IL-03	1
GEP2013IL-43	1
GEP2016IL-03	1
GEP2016IL-43	1

### 11.6 Minimum startup path

The product requires a certain minimum startup path to reach the desired gripping force.

Design size	Minimum startup path per gripper jaw [mm]
GEP2006IL-03	0.5
GEP2006IL-43	0.5
GEP2010IL-03	0.5
GEP2010IL-43	0.5
GEP2013IL-03	0.5
GEP2013IL-43	0.5
GEP2016IL-03	0.5
GEP2016IL-43	0.5

### 11.7 Easy Startup

Describes the process from switching on the product to the initial movement.

- ▶ Connect the product according to its assignment diagram.
- ⇒ The product reports the process parameters StatusWord, Diagnosis and ActualPosition immediately after the internal controller is booted up.
- ⇒ As soon as the PLCActive bit is registered in the StatusWord, the communication process can start.
- ▶ Transmit the process parameters to move the product.
  - DeviceMode
  - GripForce
  - DriveVelocity
  - BasePosition
  - WorkPosition
- ▶ Transmit the parameters to the product with a handshake.

#### INFORMATION



▶ For more information please refer to the „Handshake Data Transfer Method“ section.



## 11.8 Quickstart Basic Parameters

In the following example, you see the first initialization of the product, the activation of the motor and the transmission of the process parameters.

```
// Initialization of the product
// Motor switch-on
// Initial move command
// = EasyStartUp Example

IF bStart = TRUE THEN
    iStep          := 10;
END_IF

CASE iStep OF

10:
    IF StatusWord.6 THEN          // Query for PLCActive bit in the StatusWord
        DeviceMode      := 103;  // Command to select the universal mode
        WorkpieceNo     := 0;    // 0 = current process parameters are being used
        PositionTolerance := 50;
        GripForce       := 4;    // Gripping force setting
        BasePosition    := 100;
        TeachPosition   := 1200;
        WorkPosition    := 1200;
        ControlWord     := 1;    // Data transfer to the product
        iStep           := 20;   // Jump to the next step
    END_IF

20:
    IF StatusWord.12 THEN        // Query for DataTransferOK bit in the StatusWord
        ControlWord     := 0;    // Reset of the ControlWord
        iStep           := 30;   // Jump to the next step
    END_IF

30:
    IF NOT StatusWord.12 THEN
        ControlWord     := 512;  // Handshake is completed,
                                // Product moves to WorkPosition (0x0200 or 512(decimal) = MoveToWork)
        iStep           := 100;
    END_IF

100:
    ;                            // Continue with the program
END_CASE
```

## 11.9 Starting the gripping movement

- ▶ Send ControlWord 0x0200 so that the product moves towards the WorkPosition.
- ⇒ The gripper jaws move towards the inside.
- ▶ Send ControlWord 0x0100 so that the product moves towards the BasePosition.
- ⇒ The gripper jaws move towards the outside.
  - The motion task must be pending for as long as it takes until the desired position is reached.
  - The current motion task is canceled as a result of a new handshake.
- ⇒ When the product reaches the corresponding position, this is displayed in the StatusWord as follows:
  - The product is at the BasePosition: StatusWord bit 8 = TRUE
  - The product is at the TeachPosition: StatusWord bit 9 = TRUE
  - The product is at the WorkPosition: StatusWord bit 10 = TRUE

## 11.10 Repeated movements in the same direction

The StatusWord includes two static flag bits, each of which is set in alternation when the product moves in one direction. This prevents uncontrolled movements of the product in case of faulty data transmission.

Depending on the location of the positions, it is possible that the product may move multiple times in the same direction. For this purpose, the direction flags must be reset.

- ▶ Send the ControlWord = 0x0004 to delete the direction flags.
- ⇒ The direction flags are reset when the product answers with status bit 13 AND 14 = FALSE.

Program example for repeated movements in the same direction:

```
// Multiple movement in one direction in Structured Text (ST)
// The product is not capable of accepting multiple move commands in the same direction.
// That is why the direction flag has to be reset in the StatusWord.
// In this example, all process parameters are already correctly transferred.
// The previous move command toward the WorkPosition could not be executed
// because the product is being blocked by a workpiece.
// After the workpiece is removed, the direction flag is reset
// and the move command is restarted.

IF bReset = TRUE THEN
    iStep          := 10;
END_IF

CASE iStep OF

10:
    IF Diagnose = 16#307 THEN          // Move command could not be executed.
        iStep          := 20;        // Jump to the error step
        // to reset the direction flag
    END_IF

20:
    ControlWord      := 4;          // Reset the direction flags
    // (ResetDirectionFlag bit = TRUE in the ControlWord)
    iStep            := 30;        // Jump to the next step

30:
    IF NOT StatusWord.13 AND NOT      // Query whether both direction flags
    StatusWord.14 THEN                // (Bit ControlWord 0x0100 AND
    // ControlWord 0x0200 = FALSE in ControlWord)
        ControlWord      := 512;    // Moves back toward WorkPosition
        iStep            := 100;
    END_IF;

100:
    ;                                // Continue with the program

END_CASE
```

## 11.11 Recipe examples

### 11.11.1 Save recipe

The following example code shows how process parameters can be stored in the internal workpiece recipe.

```
// Store tool workpiece recipes in Structured Text (ST)

IF bStart = TRUE THEN
    iStep          := 10;
END_IF

CASE iStep OF

10:
    DeviceMode      := 103;    // Assignment of desired process parameters
    WorkpieceNo     := 3;      // Recipe is to be stored as the third workpiece recipe
    PositionTolerance := 50;
    BasePosition    := 100;
    WorkPosition    := 2000;
    GripForce       := 1;
    TeachPosition   := 500;
    iStep           := 20;    // Jump to the next step

20:
    ControlWord     := 1;      // Begins with the handshake
    iStep           := 30;    // Jump to the next step

30:
    IF StatusWord.12 THEN      // Queries the bit DataTransferOK=TRUE from StatusWord,
                                // Response of the product to transferred data
        ControlWord     := 0;    // Reset the ControlWord
        iStep           := 40;    // Jump to the next step
    END_IF;

40:
    IF NOT StatusWord.12 THEN  // Query for completion of the data transfer,
                                // DataTransferOK = FALSE
        ControlWord     := 2;    // Handshake is completed,
                                // storage starts here via the WritePDU bit in the ControlWord
        iStep           := 50;    // Jump to the next step
    END_IF;

50:
    IF StatusWord.12 THEN      // Queries the DataTransferOK = TRUE bit from StatusWord
        ControlWord     := 0;    // Reset the ControlWord
        iStep           := 60;    // Jump to the next step
    END_IF;

60:
    IF NOT StatusWord.12 THEN  // Query for completion of the data transfer,
                                // DataTransferOK = FALSE
        iStep           := 0;    // Storage is completed
    END_IF;

END_CASE
```

### 11.11.2 Loading a recipe

The following example code shows how process parameters can be loaded to the internal workpiece recipe.

```
// Load workpiece recipes in Structured Text (ST)

IF bLoad = TRUE THEN
    iStep          := 10;
END_IF

CASE iStep OF

10:
    WorkpieceNo    := 3;    // Load third workpiece recipe
    iStep          := 20;    // Jump to the next step

20:
    ControlWord    := 1;    // Begins with the handshake
    iStep          := 30;    // Jump to the next step

30:
    IF StatusWord.12 THEN                // Queries the bit DataTransferOK=TRUE from StatusWord,
                                        // Response of the product to transferred data
        ControlWord := 0;    // Reset the ControlWord
        iStep       := 40;    // Jump to the next step
    END_IF;

40:
    IF NOT StatusWord.12 THEN            // Query for completion of the data transfer,
                                        // DataTransferOK = FALSE
        iStep       := 0;    //Handshake is completed,
                                        // Parameters from the third recipe have been taken over into the current process parameters.
    END_IF;

END_CASE
```

## 12 Operation

### NOTICE



In the event of a power failure, the gripper jaws remain in their positions and the gripping force of the product stays constant.

The gripper jaws can be opened using the emergency release if the energy supply drops off.

► Please contact Customer Service if you have any questions.

### 12.1 Setting the gripping force

For the IO-Link variant, you can adjust the gripping force conveniently by using the control system.

### 12.2 Emergency release

The product features an emergency release that can be mechanically opened with an Allen key in the event of a power failure.

- Remove the protective cap.
- Actuate the emergency release with a corresponding Allen key.

Design size	Wrench size [mm]
GEP2006IL-03	1.5
GEP2006IL-43	1.5
GEP2010IL-03	1.5
GEP2010IL-43	1.5
GEP2013IL-03	1.5
GEP2013IL-43	1.5
GEP2016IL-03	2
GEP2016IL-43	2

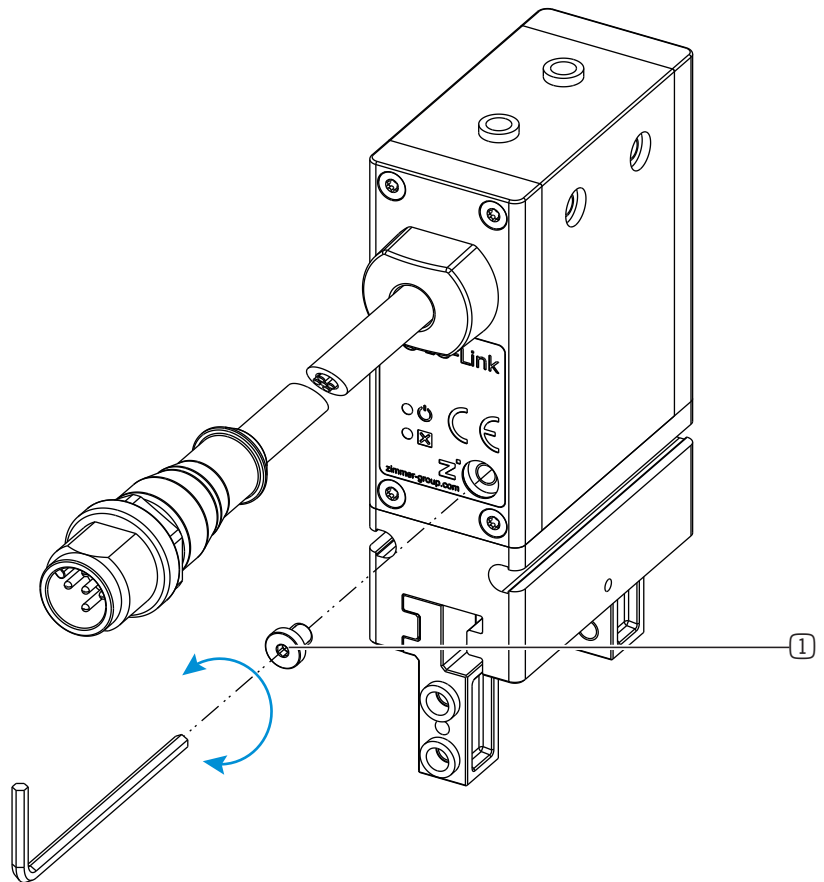

① Protective cap

## 13 Gripping force charts

### INFORMATION









- You can find information on our website.
- Please contact Customer Service if you have any questions.

## 14 Error diagnosis

Error code	Error	Possible cause	Measure
0x0000	Device is ready for operation.	-	-
0x0002	Position measuring system not referenced.	<ul style="list-style-type: none"> <li>Product is in reference run.</li> </ul>	<ul style="list-style-type: none"> <li>▶ Please contact Customer Service.</li> </ul>
0x0003	Device is booted up.	<ul style="list-style-type: none"> <li>The device is in the start sequence.</li> </ul>	<ul style="list-style-type: none"> <li>▶ Wait until the start sequence is complete.</li> </ul>
0x0100	Actuator power supply is not present or is too low	<ul style="list-style-type: none"> <li>Actuator power supply is not connected</li> <li>Actuator power supply is not sufficient</li> <li>Cable break</li> </ul>	<ul style="list-style-type: none"> <li>▶ Check the actuator power supply.</li> </ul>
0x0101	Temperature above maximum permitted temperature.	<ul style="list-style-type: none"> <li>Ambient temperature is too high.</li> <li>Overload of the products.</li> </ul>	<ul style="list-style-type: none"> <li>▶ Provide sufficient ventilation/cooling/connection.</li> <li>▶ Check that the product moves freely.</li> </ul>
0x0102	Temperature is below minimum permitted temperature.	<ul style="list-style-type: none"> <li>Ambient temperature is too low.</li> </ul>	<ul style="list-style-type: none"> <li>▶ Provide an adequate operating temperature.</li> </ul>
0x0103	Temperature of the power level is too high	<ul style="list-style-type: none"> <li>Surrounding temperature is too high</li> <li>Overload of the product</li> <li>Internal defect</li> </ul>	<ul style="list-style-type: none"> <li>▶ Ensure improved cooling of the product.</li> <li>▶ Check that the product moves freely.</li> <li>▶ Select a suitable DeviceMode.</li> </ul>
0x010B	Workpiece lost	<ul style="list-style-type: none"> <li>Gripping force is not sufficient</li> <li>Workpiece was not gripped correctly</li> <li>Gripper finger geometry does not match the gripped workpiece</li> <li>Workpiece is too heavy</li> </ul>	<ul style="list-style-type: none"> <li>▶ Check the required gripping force.</li> <li>▶ Check the gripper finger geometry.</li> <li>▶ Reset the error by sending another move command back.</li> </ul>
0x0300	ControlWord is not plausible.	<ul style="list-style-type: none"> <li>Multiple bits were set in the ControlWord.</li> </ul>	<ul style="list-style-type: none"> <li>▶ In the ControlWord, check that only one bit is set.</li> </ul>
0x0301	Positions are not plausible.	<ul style="list-style-type: none"> <li>Transmitted positions are not plausible.</li> </ul>	<ul style="list-style-type: none"> <li>▶ Check the transmitted process data.</li> </ul>
0x0302	GripForce is not plausible.	<ul style="list-style-type: none"> <li>Transmitted GripForce is not plausible.</li> </ul>	<ul style="list-style-type: none"> <li>▶ Check the transmitted process data.</li> </ul>
0x0303	DriveVelocity is not plausible.	<ul style="list-style-type: none"> <li>Transmitted DriveVelocity is not plausible.</li> </ul>	<ul style="list-style-type: none"> <li>▶ Check the transmitted process data.</li> </ul>
0x0304	PositionTolerance is not plausible.	<ul style="list-style-type: none"> <li>Transmitted PositionTolerance is not plausible.</li> </ul>	<ul style="list-style-type: none"> <li>▶ Check the transmitted process data.</li> </ul>
0x0306	DeviceMode is not plausible.	<ul style="list-style-type: none"> <li>Transmitted DeviceMode is not plausible.</li> </ul>	<ul style="list-style-type: none"> <li>▶ Check the transmitted process data.</li> </ul>
0x0307	Motion task cannot be executed (CRC error).	<ul style="list-style-type: none"> <li>Multiple motion tasks in the same direction.</li> <li>Move command transmitted despite existing error.</li> </ul>	<ul style="list-style-type: none"> <li>▶ Reset the direction flag.               <ul style="list-style-type: none"> <li>• through move command in the opposite direction</li> <li>• through error reset</li> <li>• through reset direction flag</li> </ul> </li> <li>▶ Send the move command again.</li> </ul>

Error code	Error	Possible cause	Measure
0x0308	WorkpieceNo cannot be selected.	<ul style="list-style-type: none"> <li>Transmitted workpiece number is outside the permitted range.</li> </ul>	<ul style="list-style-type: none"> <li>▶ Check the transmitted process data.</li> </ul>
0x0309	TeachPosition was changed.	<ul style="list-style-type: none"> <li>Modified process data were not taken over.</li> </ul>	<ul style="list-style-type: none"> <li>▶ Apply the process data via a handshake.</li> </ul>
0x030A	BasePosition was changed.	<ul style="list-style-type: none"> <li>Modified process data were not taken over.</li> </ul>	<ul style="list-style-type: none"> <li>▶ Apply the process data via a handshake.</li> </ul>
0x030B	ShiftPosition was changed.	<ul style="list-style-type: none"> <li>Modified process data were not taken over.</li> </ul>	<ul style="list-style-type: none"> <li>▶ Apply the process data via a handshake.</li> </ul>
0x030C	WorkPosition was changed.	<ul style="list-style-type: none"> <li>Modified process data were not taken over.</li> </ul>	<ul style="list-style-type: none"> <li>▶ Apply the process data via a handshake.</li> </ul>
0x030D	GripForce was changed.	<ul style="list-style-type: none"> <li>Modified process data were not taken over.</li> </ul>	<ul style="list-style-type: none"> <li>▶ Apply the process data via a handshake.</li> </ul>
0x030E	DriveVelocity was changed.	<ul style="list-style-type: none"> <li>Modified process data were not taken over.</li> </ul>	<ul style="list-style-type: none"> <li>▶ Apply the process data via a handshake.</li> </ul>
0x030F	TeachTolerance was changed.	<ul style="list-style-type: none"> <li>Modified process data were not taken over.</li> </ul>	<ul style="list-style-type: none"> <li>▶ Apply the process data via a handshake.</li> </ul>
0x0310	DeviceMode was changed.	<ul style="list-style-type: none"> <li>Modified process data were not taken over.</li> </ul>	<ul style="list-style-type: none"> <li>▶ Apply the process data via a handshake.</li> </ul>
0x0311	WorkpieceNo was changed.	<ul style="list-style-type: none"> <li>Modified process data were not taken over.</li> </ul>	<ul style="list-style-type: none"> <li>▶ Apply the process data via a handshake.</li> </ul>
0x0312	Initial state after gripper restart	<ul style="list-style-type: none"> <li>Modified process data were not taken over.</li> </ul>	<ul style="list-style-type: none"> <li>▶ Apply the process data via a handshake.</li> </ul>
0x0314	BasePosition ≥ WorkPosition	<ul style="list-style-type: none"> <li>Transmitted BasePosition ≥ transmitted WorkPosition</li> </ul>	<ul style="list-style-type: none"> <li>▶ Check the transmitted process data.</li> </ul>
0x0400	Difficulty of movement	<ul style="list-style-type: none"> <li>Gripper jaws are blocked.</li> <li>Gripper jaws are difficult to move.</li> </ul>	<ul style="list-style-type: none"> <li>▶ Check that the product moves freely.</li> <li>▶ Acknowledge the error.</li> </ul>
0x040B	Internal error	<ul style="list-style-type: none"> <li>Internal error</li> </ul>	<ul style="list-style-type: none"> <li>▶ Please contact Customer Service.</li> </ul>
0x0406	System error	<ul style="list-style-type: none"> <li>Internal system error</li> </ul>	<ul style="list-style-type: none"> <li>▶ Please contact Customer Service.</li> </ul>
0x0411	No production parameters present on the product.	<ul style="list-style-type: none"> <li>Internal error</li> </ul>	<ul style="list-style-type: none"> <li>▶ Please contact Customer Service.</li> </ul>

**14.1 Status in LED display for error**

	Green LED lights up continuously.	<ul style="list-style-type: none"> <li>No error</li> </ul>
	Red LED flashes every second. Green LED lights up continuously.	<ul style="list-style-type: none"> <li>No IO-Link communication</li> </ul>
	Red LED lights up continuously.	<ul style="list-style-type: none"> <li>Actuator supply not OK</li> </ul>
	Red LED flashes every second. Green LED does not light up.	<ul style="list-style-type: none"> <li>Process data are invalid.</li> <li>Internal error</li> </ul>
	Red LED flashes every second. Green LED flashes every second (at the same time).	<ul style="list-style-type: none"> <li>No reference position</li> <li>A reference run must be performed.</li> </ul>
	Red LED flashes every second. Green LED flashes every second (alternating).	<ul style="list-style-type: none"> <li>A reference run is being performed.</li> </ul>



## 15 Table with acyclic data (ISDU)

### INFORMATION



IO-Link distinguishes between cyclical process data (PDU) and acyclic data (ISDU). Access to acyclic data is not arranged very conveniently for all control system and IO-Link master combinations. For this reason, the product can be used without acyclic data. This makes it as easy as possible to control the product.

► Please contact Customer Service if you have any questions.

### INFORMATION



► Note that the acyclic data with the following parameters correspond to the reflection of the process data:

- StatusWord, Diagnosis, ControlWord, ActualPosition, TeachPosition, WorkpieceNo, DeviceMode, PositionTolerance, GripForce, DriveVelocity, BasePosition, ShiftPosition, WorkPosition

Index	Name	Data format	Access rights	Values	Description
0x0017 (23)	Firmware version	STRING	Read	-	Firmware version <ul style="list-style-type: none"> <li>• Example: SWA000170_A00</li> <li>• Type: SWA000170</li> <li>• Version: A00</li> </ul>
0x0040 (64)	StatusWord	UINT16	Read	0 - 65535	Parameter to read out the StatusWord.
0x0041 (65)	Diagnosis	UINT16	Read	0 - 65535	Read out of the diagnostic code.
0x0042 (66)	Cycle counter	UINT32	Read	0 to 4294967295	Read out of the total number of cycles.
0x0043 (67)	Temperature	UINT16	Read	0 to 100 °C	Current temperature
0x0044 (68)	ControlWord	UINT16	Read	0 - 65535	Read out the current temperature.
0x0045 (69)	Error code	STRING	Read	1 to 32	Read out of the current error state.
0x0046 (70)	Error counter	UINT32	Read	0 to 4294967295	Read out of the number of errors since the restart.
0x0100 (256)	ActualPosition	UINT16	Read	0 to max. jaw stroke of the product [0,01 mm]	Read out of the current position of the gripper jaws relative to the full stroke.
0x0101 (257)	TeachPosition	UINT16	Read	0 to max. jaw stroke of the product [0,01 mm]	Read out of the current transmitted TeachPosition.
0x0102 (258)	WorkpieceNo	UINT8	Read	0 - 32	Read out of the transmitted workpiece number.
0x0103 (259)	DeviceMode	UINT8	Read	1-103	Read out of the transmitted travel mode.
0x0104 (260)	PositionTolerance	UINT8	Read	0 to 255	Read out of the transmitted tolerance of the TeachPosition.
0x0105 (261)	GripForce	UINT8	Read	1 to 130 %	Read out of the transmitted gripping force.
0x0107 (263)	DriveVelocity	UINT8	Read	1 to 100 %	Read out of the transmitted movement speed.

Index	Name	Data format	Access rights	Values	Description
0x0108 (264)	BasePosition	UINT16	Read	0 to max. jaw stroke of the product	Read out of the transmitted outer jaw position.
0x0109 (265)	ShiftPosition	UINT16	Read	0 to max. jaw stroke of the product	Read out of the transmitted toggle position.
0x010A (266)	WorkPosition	UINT16	Read	0 to max. jaw stroke of the product	Read out of the transmitted inner jaw position.
0x0114 (276) Subindex 1 to 4	WorkPosition/ BasePosition tolerance window	UINT16	Read/write	0 - 65535	<ul style="list-style-type: none"> <li>▶ Setting the BasePosition and WorkPosition tolerance window               <ul style="list-style-type: none"> <li>• Subindex 0: Read/write</li> <li>• Subindex 1: from BasePosition to the outside</li> <li>• Subindex 2: from BasePosition to the inside</li> <li>• Subindex 3: from WorkPosition to the inside</li> <li>• Subindex 4: from WorkPosition to the outside</li> </ul> </li> <li>▶ Resetting all changes to factory settings using an IO-Link factory reset</li> </ul>
0x022F (559)	Holding current	UINT16	Read/write	0 to 1000	Amperage [%] for current after-supply scaled to the maximum permitted current.
0x0230 (560)	Holding time	UINT16	Read/write	0 to 1000	Time duration [ms] for current after-supply
0x0232 (562)	Emergency Mode	UINT16	Read/write	0 to 1	<ul style="list-style-type: none"> <li>▶ Deactivation of message 0x0400 by ISDU:               <ul style="list-style-type: none"> <li>• Index = 562 (decimal)</li> <li>• Subindex = 0</li> <li>• Value = 0</li> </ul> </li> <li>▶ Activation of message 0x0400 by ISDU:               <ul style="list-style-type: none"> <li>• Index = 562 (decimal)</li> <li>• Subindex = 0</li> <li>• Value = 1</li> </ul> </li> </ul>

## 16 Maintenance

### NOTICE



#### Material damage resulting from blowing out with compressed air

Blowing out the product with compressed air can cause malfunctions and pose a risk of accidents.

- ▶ Never purge the product with compressed air.

### NOTICE



#### Material damage caused by unsuitable cleaning materials

Liquid and solvent-based cleaning agents can cause malfunctions and pose a risk of accidents.

- ▶ Do not clean the product with any cleaning agents that are liquid or contain solvents.

### NOTICE



#### Material damage due to leaking lubricant

Excessive lubrication can cause moving machine parts to leak lubricant. This can cause soiling of the machine, the workpiece and the environment.

- ▶ Only use approved or recommended lubricants.
- ▶ Observe the manufacturer information for use of specific lubricants.
- ▶ Adhere to the lubrication interval.
- ▶ Avoid excessive lubrication.
- ▶ Remove leaking lubricant immediately and thoroughly.
- ▶ Replace damaged seals.

Maintenance-free operation of the product is guaranteed for up to 10 million cycles.

- ▶ Note that the product could become damaged under the following circumstances:
    - Dirty environment
    - Improper use and use that does not comply with the performance data
    - Permissible temperature range not observed
  - ▶ Even though the product is maintenance-free as mentioned above, perform a regular visual inspection to check for any damage or contamination.
  - ▶ Have maintenance work that requires disassembly of the product performed by customer service if possible.
- ⇒ Dismantling and reassembling the product without authorization may result in complications, as special installation equipment is required in some cases. Zimmer GmbH accepts no liability for any resulting malfunctions or damage.

## 17 Decommissioning/disposal

### INFORMATION



When the product reaches the end of its operational phase, it can be completely disassembled and disposed of.

- ▶ Disconnect the product completely from the power supply.
- ▶ Dispose of the components properly according to the material groups.
- ▶ Comply with the locally applicable environmental and disposal regulations.

## 18 RoHS declaration

in terms of the EU Regulation 2011/65/EU

### Name and address of the manufacturer:

#### Zimmer GmbH

📍 Im Salmenkopf  
77866 Rheinau, Germany  
☎ +49 7844 9138 0  
✉ [info@zimmer-group.com](mailto:info@zimmer-group.com)  
🌐 [www.zimmer-group.com](http://www.zimmer-group.com)

We hereby declare that the incomplete machine described below

**Product designation:** 2-jaw parallel gripper, electric

**Type designation:** GEP2000IL-03, GEP2000IL-43

conforms to the requirements of the directive in its design and the version we put on the market.

Michael Hoch  
Authorized representative for the  
compilation of relevant technical  
documents

Rheinau, Germany, 2022-10-04  
(Place and date of issuance)



Martin Zimmer  
(Legally binding signature)  
Managing Partner

## 19 REACH declaration

In terms of the EC Regulation 1907/2006

### Name and address of the manufacturer:

#### Zimmer GmbH

📍 Im Salmenkopf  
77866 Rheinau, Germany  
☎ +49 7844 9138 0  
✉ [info@zimmer-group.com](mailto:info@zimmer-group.com)  
🌐 [www.zimmer-group.com](http://www.zimmer-group.com)

REACH stands for **R**egistration, **E**valuation, **A**uthorisation and **R**estriction of **C**hemicals.

A full declaration of REACH can be obtained from the manufacturer due to the duty to notify in accordance with Art. 33 of the REACH regulation ("Duty to communicate information on substances in articles").

Michael Hoch  
Authorized representative for the  
compilation of relevant technical  
documents

Rheinau, Germany, 2022-10-04  
(Place and date of issuance)



Martin Zimmer  
(Legally binding signature)  
Managing Partner

## 20 Declaration of Incorporation

In terms of the EU Machinery Directive 2006/42/EC (Annex II 1 B)

**Name and address of the manufacturer:**

**Zimmer GmbH**

📍 Im Salmenkopf  
77866 Rheinau, Germany  
☎ +49 7844 9138 0  
✉ [info@zimmer-group.com](mailto:info@zimmer-group.com)  
🌐 [www.zimmer-group.com](http://www.zimmer-group.com)

We hereby declare that the incomplete machine described below

**Product designation:** 2-jaw parallel gripper, electric  
**Type designation:** GEP2000IL-03, GEP2000IL-43

conform to the requirements of the Machinery Directive, 2006/42/EC, Article 2g, Annex VII.b – Annex II.b, in its design and the version we put on the market.

Basic health and safety requirements:

No. 1.1.2, No. 1.1.3, No. 1.1.5, No. 1.3.2, No. 1.3.4, No. 1.3.7, No. 1.3.9, No. 1.5.1, No. 1.5.2, No. 1.5.4, No. 1.6.4, No. 1.7.1, No. 1.7.4

A full list of applied standards can be obtained from the manufacturer.

We also declare that the specific technical documents were produced in accordance with Annex VII Part B of this Directive. We undertake to provide the market supervisory bodies with electronic versions of special documents for the incomplete machine through our documentation department, should they have reason to request them.

**The incomplete machine may only be commissioned if it has been ascertained, if applicable, that the machine or system in which the incomplete machine is to be installed satisfies the requirements of Directive 2006/42/EC on Machinery and an EC Declaration of Conformity has been drawn up in accordance with Annex II 1 A.**

Kurt Ross  
Authorized representative for the compilation of relevant technical documents

Rheinau, Germany, 2022-10-04  
(Place and date of issuance)



Martin Zimmer  
(Legally binding signature)  
Managing Partner

## 21 Declaration of Conformity

As defined by the EC Directive 2014/30/EU on electromagnetic compatibility

### Name and address of the manufacturer:

#### Zimmer GmbH

📍 Im Salmenkopf  
77866 Rheinau, Germany  
☎ +49 7844 9138 0  
✉ [info@zimmer-group.com](mailto:info@zimmer-group.com)  
🌐 [www.zimmer-group.com](http://www.zimmer-group.com)

We hereby declare that the products described below

**Product designation:** 2-jaw parallel gripper, electric

**Type designation:** GEP2000IL-03, GEP2000IL-43

conforms to the requirements of the 2006/42/EC directive in its design and the version we put on the market.

The following harmonized standards have been used:

DIN EN ISO 12100	Safety of machinery - General principles for design - Risk assessment and risk reduction
DIN EN 61000-6-3	EMC Generic standard, Emission standard for residential, commercial and light-industrial
DIN EN 61000-6-2	EMC Generic standard, Emission standard for industrial environments
DIN EN 61000-6-4	EMC Generic standard, Immunity for industrial environments

A full list of applied standards can be obtained from the manufacturer.

Kurt Ross

Authorized representative for the compilation of relevant technical documents

Rheinau, Germany, 2022-10-04

(Place and date of issuance)

Martin Zimmer  
(Legally binding signature)  
Managing Partner