

INSTALLATION AND OPERATING INSTRUCTIONS

Rotary clamping element,
pneumatic
DKPS1000

DDOC01621

THE KNOW-HOW FACTORY

Content

1	Supporting documents	4
1.1	Notices and graphics in the installation and operating instructions	4
2	Safety notices	5
3	Proper use	6
4	Personnel qualification	6
4.1	Electricians	6
4.2	Specialists	6
4.3	Instructed personnel.....	6
4.4	Service personnel.....	6
4.5	Additional qualifications	6
5	Product description	6
5.1	Type plate	7
6	Functional description	8
7	Technical data	8
8	Accessories/scope of delivery	9
9	Transportation/storage/preservation	9
10	Installation	10
10.1	Installing the product.....	11
10.1.1	Installing the product with energy supply from above.....	13
10.1.2	Installing the product with energy supply from below	14
10.2	Installing the sensors.....	17
10.2.1	Adjusting the magnetic field sensors.....	17
10.3	Installing accessories	18
11	Commissioning	19
11.1	Checking operational readiness.....	19
12	Maintenance.....	20
13	Decommissioning/disposal	20
14	Declaration of Conformity	21

1 Supporting documents

NOTICE



Read through the installation and operating instructions before installing or working with the product.

The installation and operating instructions contain important notes for your personal safety. They must be read and understood by all persons who work with or handle the product during any phase of the product lifetime.



The documents listed below are available for download on our website www.zimmer-group.com.

- Installation and operating instructions
 - Catalogs, drawings, CAD data, performance data
 - Information on accessories
 - Technical data sheets
 - General Terms and Conditions, including warranty information.
- ⇒ Only those documents currently available on the website are valid.

In these installation and operating instructions, "product" refers to the product designation on the title page!

1.1 Notices and graphics in the installation and operating instructions

DANGER



This notice warns of an imminent danger to the life and health of people. Ignoring these notices can lead to serious injury or even death.

- ▶ You absolutely must comply with the described measures for avoiding these dangers!
- ⇒ The warning symbols are assigned according to the type of danger.

WARNING



This notice warns of a situation that is potentially hazardous to personal health. Ignoring these notices can cause serious injury or damage to health.

- ▶ You absolutely must comply with the described measures for avoiding these dangers!
- ⇒ The warning symbols are assigned according to the type of danger.

CAUTION



This notice warns of a situation that is potentially hazardous to persons. Ignoring these notices can cause minor, reversible injuries.

- ▶ You absolutely must comply with the described measures for avoiding these dangers!
- ⇒ The warning symbols are assigned according to the type of danger.

NOTICE



This notice warns of possible material and environmental damage. Ignoring these notices can result in damage to the product or the environment.

INFORMATION



This category contains useful tips for handling the product efficiently. Failure to observe these tips will not result in damage to the product. This information does not include any information relevant to health or workplace safety.

2 Safety notices

CAUTION



Risk of injury and material damage in case of non-compliance

Installation, commissioning, maintenance and repairs may only be performed by qualified specialists in accordance with these installation and operating instructions.

The product is state-of-the-art.

The following are examples of situations in which the product may cause a hazard:

- The product is not properly installed, used or maintained.
- The product is not used for its designated purpose.
- The locally applicable regulations, laws, directives or guidelines are not observed.
- ▶ The product may only be used in accordance with these installation and operating instructions and the product's technical data. Any changes or additions to the intended use of the product, as well as modifications to the product, such as those in the following examples, require the written permission of the manufacturer:
 - Use of the product under extreme conditions, such as aggressive fluids or abrasive dusts
 - Additional drilled holes or threads
- ⇒ Zimmer GmbH shall accept no liability for any damage caused by improper use. The operator bears sole responsibility.
- ▶ Make sure that the power supply is disconnected before you mount, adjust, modify, maintain or repair the product.
- ▶ Avoid energy supply faults (e.g. due to pressure fluctuations).
- ▶ Whenever work is carried out on the product, make sure that the product cannot be actuated by mistake.
- ▶ Perform maintenance tasks, renovation work or attachment work outside of the machine's danger zone when possible.
- ▶ Do not reach into the operational range of the product.
- ▶ Always adhere to the required maintenance intervals.
- ▶ When using the product under extreme conditions, adjust the maintenance interval according to the degree of contamination.
- ▶ Check the completeness and tightening torques of all mounting screws.

3 Proper use

NOTICE



The product is only to be used in its original state with its original accessories, with no unauthorized changes and within the stipulated parameter limits and operating conditions.

Any other or secondary use is deemed improper.

- ▶ Operate the product only in compliance with the associated installation and operating instructions.
- ▶ Operate the product only when it is in a technical condition that corresponds to the guaranteed parameters and operating conditions.
- ⇒ Zimmer GmbH shall accept no liability for any damage caused by improper use. The operator bears sole responsibility.

- The product is designed exclusively for pneumatic operation.
- The product is designed solely for torque absorption on rotating machine components.

The product may only be used for the static clamping of axes or shafts.

The product is not suited for use as a bearing.

The product may only be used in combination with the brake flange used for braking approved by Zimmer GmbH.

- The product does not feature any guide characteristics. Guidance must be performed externally.

4 Personnel qualification

WARNING



Injuries and material damage due to inadequate qualification

If inadequately qualified personnel perform work on the product, this can cause serious injuries and significant material damage.

- ▶ All work on the product must be performed by qualified personnel.
- ▶ Before working with the product, read the document in its entirety and make sure that you have understood everything.
- ▶ Observe country-specific accident prevention regulations and the general safety notices.

The following qualifications are a prerequisite for performing various work on the product.

4.1 Electricians

Electricians are able to perform work on electrical systems, can recognize and avoid possible dangers and know the relevant standards and provisions due to their technical training, knowledge and experience.

4.2 Specialists

Specialists are able to perform the assigned work, can recognize and avoid possible dangers and know the relevant standards and provisions due to their technical training, knowledge and experience.

4.3 Instructed personnel

Instructed personnel have been trained by the operating company on the tasks and possible dangers of improper behavior.

4.4 Service personnel

Service personnel are able to perform the assigned work and can recognize and avoid possible dangers due to their technical training, knowledge and experience.

4.5 Additional qualifications

Persons who work with the product must be familiar with the valid safety regulations and laws as well as the standards, guidelines and laws listed in this document.

Personnel who work with the product must have facility-issued authorization to commission, program, configure, operate, maintain and also decommission this product.

5 Product description

The product is a pneumatically operated rotary clamping element.

The product fixates rotation axes with high angle accuracy during torque absorption.

The product has a spring energy accumulator and is closed in the de-energized state.

5.1 Type plate

A type plate, as a laser engraving, is affixed to the housing of the product.

The article number and confirmation number are shown on the type plate.

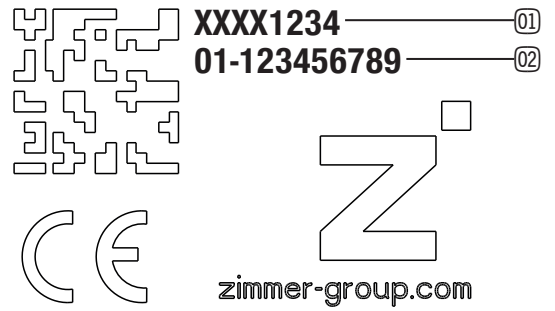

① Article number

② Confirmation number

INFORMATION



- ▶ Do not remove the laser engraving on the product.
- ▶ Do not modify the laser engraving on the product.
- ⇒ Zimmer GmbH shall accept no liability for possible damage or complaints about a product with a modified or removed laser engraving.

6 Functional description

The housing is pressurized with pneumatic pressure which sets two opposite pistons into motion. These each put pressure on pretensioned disk springs and deflects them.

The inner diameter of the product increases slightly from this and releases the shaft.

The product is closed in a pressureless state that ensures that all moving components are held securely if the pressure drops or the entire system fails.

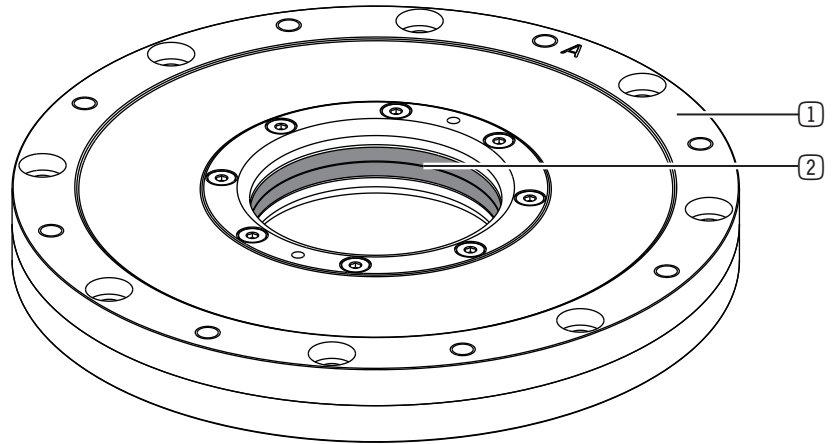

- ① Case
- ② Clamping area

7 Technical data

Service life	
B10d value [cycles]	3 million

INFORMATION



- ▶ You can find the information in the technical data sheet on our website.
- ▶ This data varies within the series, depending on the specific design.
- ▶ Please contact Customer Service if you have any questions.

INFORMATION



- ▶ The holding torque is specified in the technical data sheet depending on the size.
- ▶ The holding torque corresponds to the maximum torque to which the product may be loaded.
- ▶ Due to the stiffness of the product, there may also be some twisting below the holding torque.
- ▶ If the application has a specific requirement regarding stiffness, the holding torque should be reduced until reaching the required accuracy.
- ▶ The following factors can be used as a reference value starting from the shaft diameter.

Shaft diameter [mm]	Holding torque [%]	Accuracy [arsec]
50 - 90	approx. 80	< 50
100 - 160	approx. 80	< 20

8 Accessories/scope of delivery

INFORMATION



If any accessories not sold or authorized by Zimmer GmbH are used, the function of the product cannot be guaranteed. Zimmer GmbH accessories are specifically tailored to the individual products.

- ▶ For optional accessories and those included in the scope of delivery, refer to our website.

9 Transportation/storage/preservation

- ▶ Transport and storage of the product must be done only with the original packaging.
- ▶ If the product has already been installed on the superordinate machine unit, care must be taken during transport to ensure that no unexpected movements can occur.
 - ▶ Before commissioning the product and after transport, check all power and communication connections as well as all mechanical connections.
- ▶ If the product is stored for an extended period, the following points are to be observed:
 - ▶ Keep the storage location as dust-free and dry as possible.
 - ▶ Avoid temperature fluctuations.
 - ▶ Avoid wind/drafts/water condensation formation.
 - ▶ Package the product so that it is protected from corrosion.
 - ▶ Place additional desiccant under the film as necessary.
 - ▶ Pack the product and do not expose it to direct sunlight during storage.
- ▶ Clean all components. There must be no soiling left on the components.
- ▶ Visually inspect all components.
- ▶ Remove all foreign substances.
- ▶ Apply corrosion protection to the product.
- ▶ Close off unused connections using pressure-resistant closures.

10 Installation

WARNING



Risk of death due to unsuitable lifting equipment

- ▶ Use suitable lifting equipment for overhead assembly or disassembly of the product if the dead weight of the product is > 3 kg.

WARNING



Risk of injury caused by inadequate installation materials

If unsuitable mounting elements are used or if the number of mounting elements is insufficient, the product may tear off as a result of the load.

- ▶ Use a suitable mounting piece.
- ▶ Use suitable mounting screws.

WARNING



Risk of injury due to uncontrolled movements

Risk of injury in case of unexpected movement of the machine or system into which the product is to be installed.

- ▶ Switch off the energy supply of the machine before any work.
- ▶ Secure the power supply against being switched on unintentionally.
- ▶ Check the machine for any residual energy that may be present.
- ▶ Make sure that the function of the air relief connections is not impaired by the mounting piece.

CAUTION



Risk of injury due to uncontrolled movements

Risk of injury in the event of uncontrolled movement of the product when the power supply is connected.

- ▶ Switch off the power supply to the machine before carrying out any work.
- ▶ Secure the power supply against being switched on unintentionally.
- ▶ Check the machine for any residual energy that may be present.

NOTICE



Installation may only be carried out by qualified personnel in accordance with these installation and operating instructions.

- ▶ Switch off the power supply before any assembly, installation or maintenance work.

- ▶ Make sure that the mounting piece is sufficiently rigid.

- ▶ Observe the tightening torque of the mounting screws.
- ▶ Verify the permitted load capacity of the required screw connections in accordance with VDI 2230.

INFORMATION



Further installation information:

- The mounting screws are not included in the scope of delivery.

Shaft diameter [mm]	50 – 90
Mounting screw thread size	M5
Strength class (DIN EN ISO 4762)	12.9
Tightening torque [Nm]	9.3
Shaft diameter [mm]	100 - 160
Mounting screw thread size	M6
Strength class (DIN EN ISO 4762)	12.9
Tightening torque [Nm]	15.7

10.1 Installing the product

WARNING



Risk of injury due to incorrect installation

The disassembly of housing parts decreases the holding torque. If installed incorrectly, there is the possibility of a complete loss of function.

- ▶ During product installation, follow the order listed in the installation and operating instructions.

CAUTION



Risk of injury caused by falling parts

Operating pressure that is too high or short-term pressure peaks over the maximum permitted operating pressure can lead to a fault or the destruction of the product.

The holding torque can decrease.

- ▶ Maintain the maximum permitted operating pressure.
- ▶ Use a pressure relief valve.

NOTICE



- ▶ The authorized connections that are available can be found in the accessories list on our website. The necessary ordering information can also be found there.
- ▶ Use compressed air in accordance with DIN ISO 8573-1 [4:4:4].

NOTICE



Requirements for the mounting surface:

- Mounting surface to which the product on the mounting piece may be mounted:
Outside diameter of the product - annular surface diameter

Mounting surface

Permissible unevenness [mm]	0.05
Required rectangularity to the rotation axis [mm]	0.02
Required total radial runout of the shaft [mm]	0.02

Shaft

Tolerance of diameter [mm]	- 0,01/- 0,025
Surface roughness/Ra [µm]	0.8
Hardness [HRC]	58+4
Case hardening depth (EHT) [mm]	0.8

INFORMATION



The tolerance range of the shaft can be increased further with lower requirements for the holding torque and accuracy.

- Please contact Customer Service in this regard.

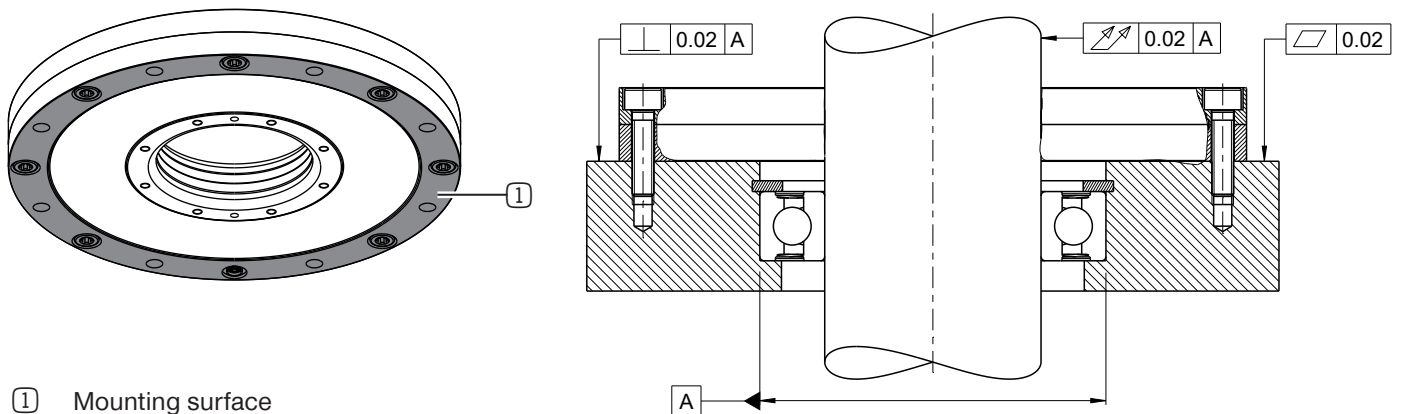

1 Mounting surface

The product can be installed to the mounting piece from above via the pneumatic connection or from below via the mirrored drilling pattern.

INFORMATION



Recommendation

- Use a quick exhaust valve at a distance of < 1000 mm to the product in order to achieve the closing times specified in the technical data sheet.

NOTICE



Non-compliance may result in material damage.

- The clamping surfaces must be free of preservation and lubrication materials before installation.
- Clean the clamping surfaces with suitable cleaning materials.

10.1.1 Installing the product with energy supply from above

NOTICE



Non-compliance may result in material damage.

The shaft must be free of lubricants before clamping installation.

▶ Clean the mounting surface and shaft of the mounting piece with suitable cleaning materials.

▶ Remove the top grub screw.

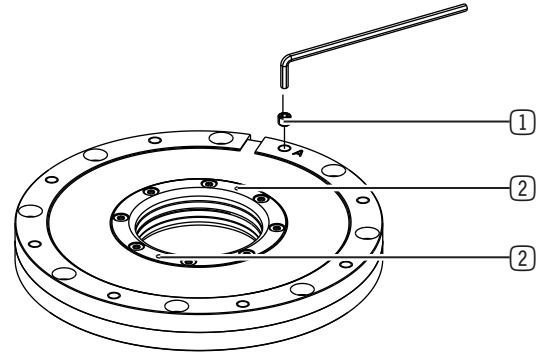

① Top grub screw

② Bleed connection

▶ Check the pressure setting and functionality of the pressure relief valve.

▶ Mount the screw fitting in the provided connection.

▶ Apply the corresponding operating pressure to the product.

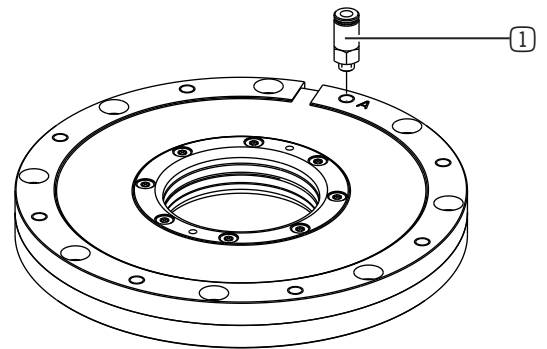

① Screw fitting

▶ Push the product onto the shaft.

▶ Position the product on the mounting piece.

▶ Loosely attach the mounting screws.

▶ Bleed and pressurize the product several times in succession.

⇒ The product centers itself to the shaft.

▶ Tighten the mounting screws crosswise.

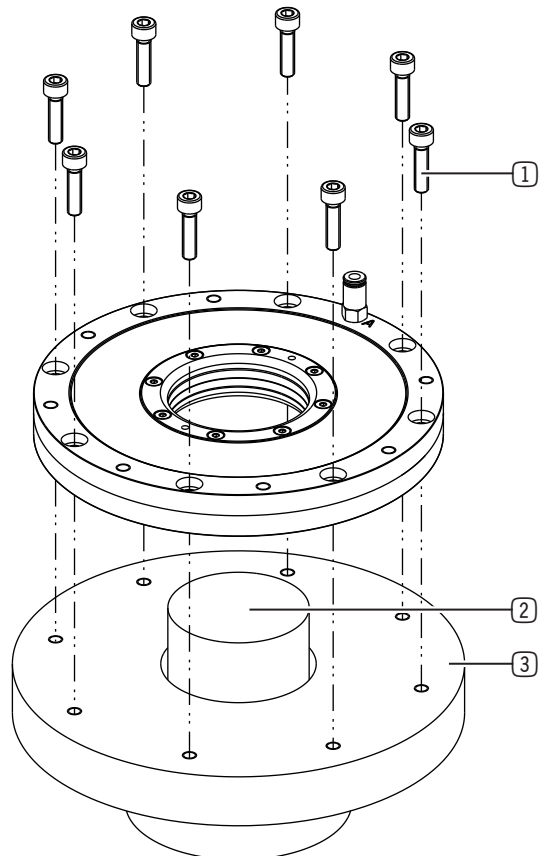

① Mounting screw

② Shaft

③ Mounting piece

10.1.2 Installing the product with energy supply from below

Mounting piece

Surface roughness/Ra [μm]	≤ 1.6
--	------------

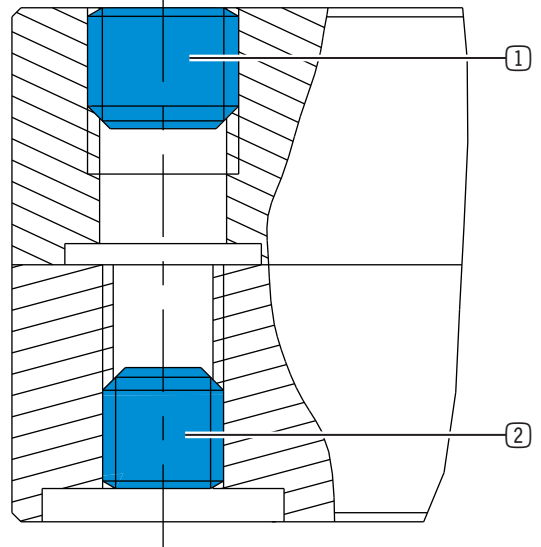

- ① Top grub screw
- ② Bottom grub screw

NOTICE



Non-compliance may result in material damage.

The shaft must be free of lubricants before clamping installation.

► Clean the mounting surface and shaft of the mounting piece with suitable cleaning materials.

- Remove the top grub screw.
- Remove the bottom grub screw.

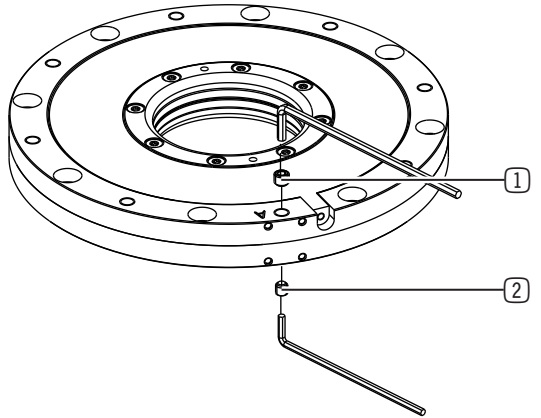

- ① Top grub screw
- ② Bottom grub screw

- Insert the bottom grub screw into the connection from above.
- Turn the grub screw until it reaches the bottom housing half.

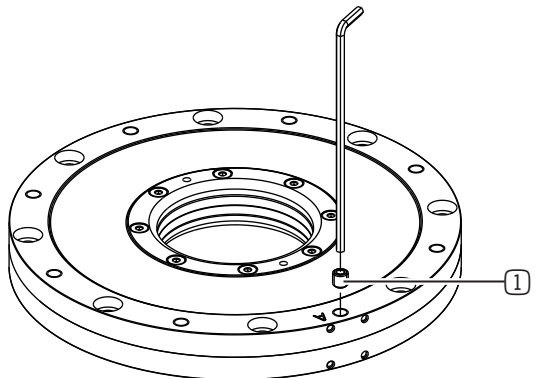

- ① Bottom grub screw

- ▶ Check the pressure setting and functionality of the pressure relief valve.
- ▶ Mount the screw fitting in the provided connection.
- ▶ Apply the corresponding operating pressure to the product.

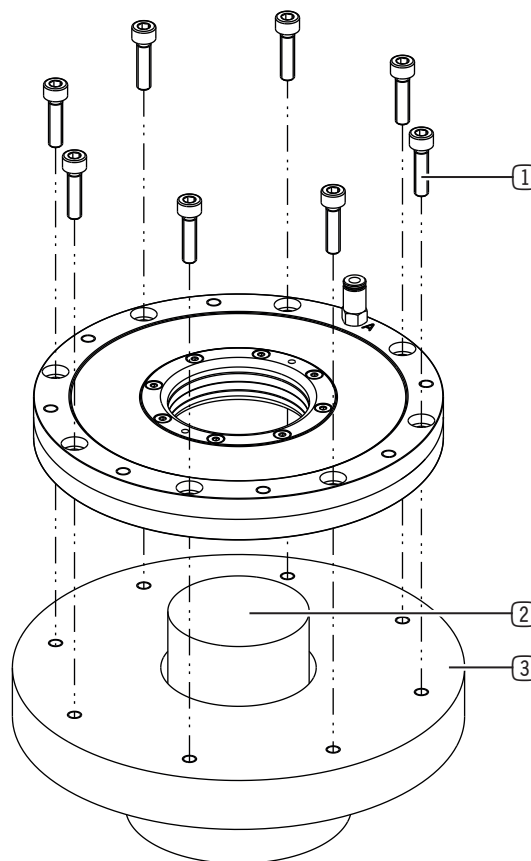
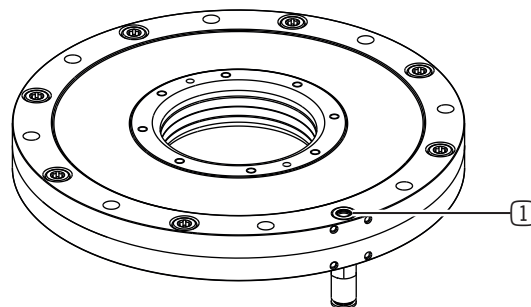
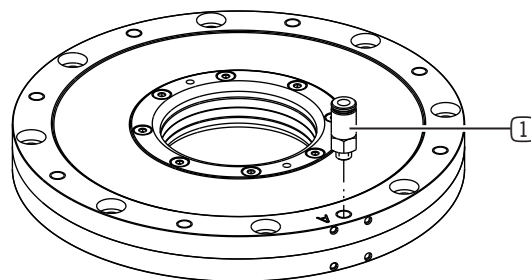

① Screw fitting

- ▶ Turn the product.
- ▶ Check whether the O-ring is inserted properly at the bottom connection.

① O-Ring

- ▶ Push the product onto the shaft.
- ▶ Position the product on the mounting piece.
- ▶ Loosely attach the mounting screws.
- ▶ De-aerate the product completely.
- ⇒ The product centers itself to the shaft.
- ▶ Tighten the mounting screws crosswise.

① Mounting screw

② Shaft

③ Mounting piece

- ▶ Remove the screw fitting from the connection.

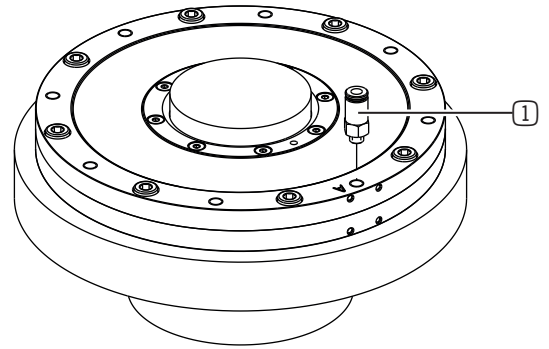

① Screw fitting

- ▶ Remove the bottom grub screw.
- ▶ Coat the thread of the top grub screw with a suitable thread sealant.
- ▶ Insert the top grub screw into the connection from above.
- ▶ Loosely screw in grub screw until the surface of the product and the grub screw are flush.

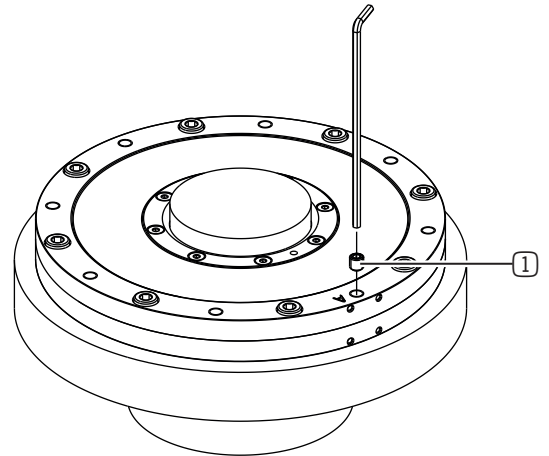

① Bottom grub screw

10.2 Installing the sensors

10.2.1 Adjusting the magnetic field sensors

NOTICE



► Note that switching point shifts may occur if the sensors are exposed to an additional, external magnetic field.

INFORMATION



You can purchase the sensor and the appropriate attachment kit as accessories.

- For information on optional accessories and those included in the scope of delivery, refer to our website.
- More information can be found in the installation and operating instructions of the sensor.

The appropriate attachment kit is required for installing the sensor.

- Install the attachment kit on the product using the countersunk screw.

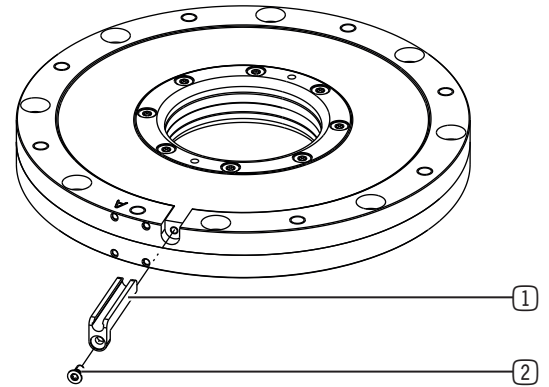

- ① Attachment kit
- ② Countersunk screw

The sensor is used for piston position sensing.

- Push the sensor in the attachment kit until the front is flush with the holder.
- Teach the switch point of the sensor with the clamping open under operating pressure according to the following table.
- Check the function of the sensor using the LED display on the sensor.

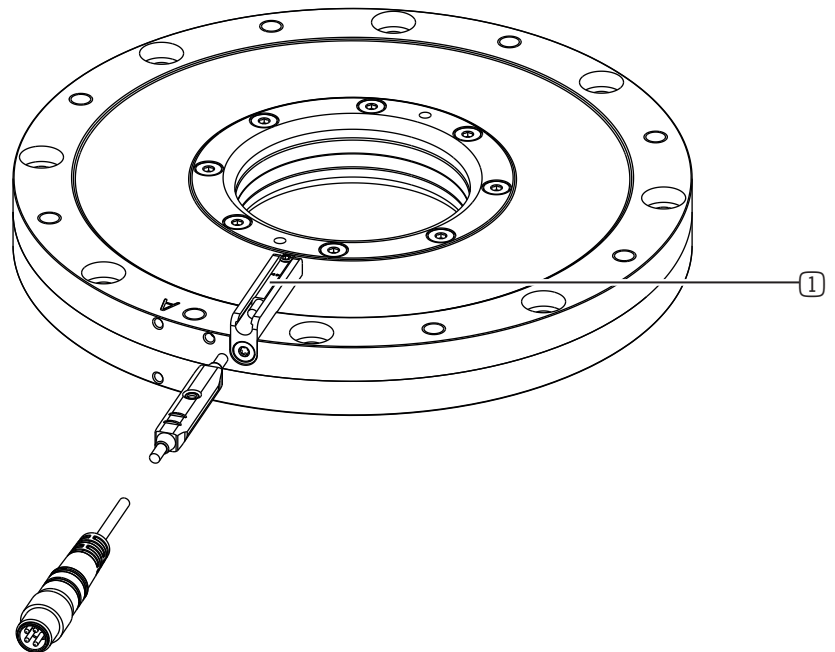

- ① Sensor

Opening pressure [bar]	Operating pressure [bar]
3.5	4
5.5	6

10.3 Installing accessories

NOTICE



- ▶ Before installing an accessory, make sure it is suitable for use with the selected variant.
- ▶ You can find information on our website.
- ▶ Please contact Customer Service if you have any questions.

INFORMATION



- ▶ See the brake flange installation instructions on our website for information on brake flange installation.
-

11 Commissioning

CAUTION



Risk of burns from hot surfaces

During operation and commissioning, the surfaces of the product may become hot.

- ▶ Keep temperature-sensitive parts away from hot surfaces.
- ▶ Do not install any temperature-sensitive parts to a product with hot surfaces.
- ▶ Only touch the product while wearing appropriate personal protective equipment.

CAUTION



Risk of injury caused by falling parts

Operating pressure that is too high or short-term pressure peaks over the maximum permitted operating pressure can lead to a fault or the destruction of the product.

The holding torque can decrease.

- ▶ Maintain the maximum permitted operating pressure.
- ▶ Use a pressure relief valve.

11.1 Checking operational readiness

WARNING



Risk of injury due to uncontrolled movements

An emergency stop of the complete machine and the accompanying emergency braking of the product can lead to a decrease of the holding torque. The malfunction resulting from this can lead to injuries.

- ▶ After an emergency stop, check the operational readiness of the product.
- ▶ Depressurize the product.
 - ▶ Initiate a torque that corresponds to the maximum holding torque of the product.
 - ▶ Make sure that the shaft does not warp in this status.
- ⇒ The clamping surfaces of the product are worn if it is discovered that the shaft is warped.
- ▶ Do not put the product into operation again until the operational readiness has been checked successfully.

CAUTION



Risk of injury due to uncontrolled movements

Contact with lubricants can lead to a decrease in the holding torque. The malfunctions resulting from this can lead to injuries.

- ▶ Check the product regularly for lubricants in the clamping area.
- ▶ Clean the clamping area if the product comes into contact with lubricants.
- ▶ Check the operational readiness of the product if the product comes into contact with lubricants.

- ▶ Check all mounting screws for the prescribed tightening torque.
- ▶ Check all connections for leaks.
- ▶ Check the ease of movement of the product with the power connected by moving it manually.
 - ▶ Ensure that rotating components on the machine do not result in an increase in torque on the product.
- ▶ Check the clamping process by applying the appropriate torque to the shaft in the de-energized state.

12 Maintenance

CAUTION



Material damage resulting from blowing out with compressed air

Blowing out the product with compressed air can cause malfunctions and pose a risk of accidents.

- ▶ Never purge the product with compressed air.

CAUTION



Material damage caused by liquid and solvent-based cleaners

Liquid and solvent-based cleaning agents can cause malfunctions and pose a risk of accidents.

- ▶ Do not clean the product with any cleaning agents that are liquid or contain solvents.

When used properly, there are no known limitations until the specified number of cycles has been reached.

The service life may shorten under the following circumstances:

- Dirty environment
 - Improper use and use that does not comply with the power specifications.
 - Operation with impermissible compressed air
 - Permissible temperature range not observed
- ▶ Even though the product is maintenance-free as mentioned above, perform a regular visual inspection to check for any damage or contamination.
- ⇒ Dismantling and reassembling the product without authorization may result in complications, as special installation equipment is required in some cases. Zimmer GmbH accepts no liability for any resulting malfunctions or damage.

13 Decommissioning/disposal

INFORMATION



When the product reaches the end of its operational phase, it can be completely disassembled and disposed of.

- ▶ Disconnect the product completely from the power supply.
- ▶ Dispose of the components properly according to the material groups.
- ▶ Comply with the locally applicable environmental and disposal regulations.

14 Declaration of Conformity

In terms of the EU Machinery Directive 2006/42/EC (Annex II 1 A)

Name and address of the manufacturer:

Zimmer GmbH

- 📍 Im Salmenkopf
77866 Rheinau, Germany
- ☎ +49 7844 9138 0
- ✉ info@zimmer-group.com
- 🌐 www.zimmer-group.com

We hereby declare that the products described below

Product designation: Rotary clamping element, pneumatic

Type designation: DKPS1000

conforms to the requirements of the 2006/42/EC directive in its design and the version we put on the market.

The following harmonized standards have been used:

- DIN EN ISO 12100 Safety of machinery - General principles for design - Risk assessment and risk reduction
- DIN EN ISO 13849-1/-2 Safety of machinery - Safety-related parts of control systems
- DIN EN ISO 4414 Pneumatic fluid power - General rules and safety requirements for systems and their components

A full list of applied standards can be obtained from the manufacturer.

Michael Hemler

Authorized representative for the compilation of relevant technical documents

Rheinau, Germany, 2022-06-28

(Place and date of issuance)



Martin Zimmer
(Legally binding signature)
Managing Partner