



INSTALLATION AND OPERATING INSTRUCTIONS

Magnetic field sensor with IO-Link
and analog output

MFS02-S-KHC-IL

DDOC01932

THE KNOW-HOW FACTORY

Content

| | | |
|---------|---|----|
| 1 | Supporting documents | 4 |
| 1.1 | Notices and graphics in the installation and operating instructions | 4 |
| 2 | Safety notices..... | 5 |
| 3 | Proper use | 5 |
| 4 | Personnel qualification | 5 |
| 4.1 | Electricians | 5 |
| 4.2 | Specialists | 5 |
| 4.3 | Instructed personnel..... | 5 |
| 4.4 | Service personnel..... | 5 |
| 4.5 | Additional qualifications | 5 |
| 5 | Product description | 6 |
| 5.1 | Detection range..... | 6 |
| 6 | Functional description | 7 |
| 7 | Technical data | 7 |
| 8 | Transportation/storage/preservation | 7 |
| 9 | Installation | 8 |
| 9.1 | Installing the product..... | 8 |
| 10 | Electrical installation..... | 8 |
| 10.1 | DC..... | 8 |
| 11 | Commissioning | 9 |
| 11.1.1 | Commissioning the product without IO-Link | 9 |
| 11.1.2 | Commissioning the product with IO-Link | 9 |
| 11.1 | Teaching in switch points | 10 |
| 11.1.1 | Dynamic teach-in | 10 |
| 11.1.2 | Manual teach-in..... | 11 |
| 11.2 | Resetting switch points | 11 |
| 11.3 | Process data structure | 13 |
| 11.3.1 | General functions | 13 |
| 11.4 | Setting options via IO-Link | 14 |
| 11.4.1 | Locking the Teach-in button | 14 |
| 11.4.2 | Resetting settings..... | 15 |
| 11.4.3 | Setting the position offset..... | 16 |
| 11.4.4 | Teaching-in two or three switch points dynamically..... | 16 |
| 11.4.5 | Teaching-in up to eight switch points manually | 16 |
| 11.4.6 | Selecting the switch point mode | 17 |
| 11.4.7 | Switching behavior after dynamic teach-in..... | 19 |
| 11.4.8 | Inverting the switch point logic..... | 22 |
| 11.4.9 | Adjusting the switch point hysteresis..... | 22 |
| 11.4.10 | Setting the switch point tolerance..... | 22 |
| 11.4.11 | Determining the switch point width..... | 22 |
| 11.4.12 | Issuing alert notifications | 22 |
| 11.5 | Diagnostic functions via IO-Link | 23 |
| 11.5.1 | Stroke | 23 |
| 11.5.2 | Cycle time..... | 23 |
| 11.5.3 | Dwell time at the start and end position | 23 |
| 11.5.4 | Piston travel time for extend and retract..... | 23 |
| 11.5.5 | Average piston velocity | 24 |
| 11.5.6 | Current measured field strength | 24 |

- 11.5.7 Maximum measured field strength24
- 11.5.8 Number of cycles.....24
- 11.5.9 Total piston travel.....24
- 11.5.10 Operating hours.....24
- 11.5.11 Power-on and power-off cycles.....24
- 12 Operation..... 25
 - 12.1 LED display during operation25
- 13 Error diagnosis 26
- 14 Maintenance..... 26
- 15 Decommissioning/disposal 26
- 16 Declaration of Conformity 27
- 17 Appendix 28
 - 17.1 IO-Link supplement.....28
 - 17.1.1 Device features28
 - 17.1.2 Physical layer28
 - 17.1.3 Process data28
 - 17.1.4 Service data29

1 Supporting documents

NOTICE



Read through the installation and operating instructions before installing or working with the product.

The installation and operating instructions contain important notes for your personal safety. They must be read and understood by all persons who work with or handle the product during any phase of the product lifetime.



The documents listed below are available for download on our website www.zimmer-group.com:

- Installation and operating instructions
- Catalogs, drawings, CAD data, performance data
- Information on accessories
- Technical data sheets
- General Terms and Conditions (GTCs), including warranty information.

⇒ Only the documents currently available on the website are valid.

In these installation and operating instructions, "product" replaces the product designation on the title page.

1.1 Notices and graphics in the installation and operating instructions

DANGER



This notice warns of an imminent danger to the life and health of people. Ignoring these notices can lead to serious injury or even death.

▶ You absolutely must comply with the described measures for avoiding these dangers.

⇒ The warning symbols are assigned according to the type of danger.

WARNING



This notice warns of a situation that is potentially hazardous to personal health. Ignoring these notices can cause serious injury or damage to health.

▶ You absolutely must comply with the described measures for avoiding these dangers.

⇒ The warning symbols are assigned according to the type of danger.

CAUTION



This notice warns of a situation that is potentially hazardous to people. Ignoring these notices can cause minor, reversible injuries.

▶ You absolutely must comply with the described measures for avoiding these dangers.

⇒ The warning symbols are assigned according to the type of danger.

NOTICE



This notice warns of possible material or environmental damage. Ignoring these notices can result in damage to the product or the environment.

▶ You absolutely must comply with the described measures for avoiding these dangers.

⇒ The warning symbols are assigned according to the type of danger.

INFORMATION



This category contains useful tips for handling the product efficiently. Failure to observe these tips will not result in damage to the product. This information does not include any information relevant to health or workplace safety.

2 Safety notices

NOTICE



In accordance with the EC Machinery Directive, the product is not a safety component.

3 Proper use

NOTICE



The product is only to be used in its original state with its original accessories, with no unauthorized changes and within the stipulated parameter limits and operating conditions.

Any other or secondary use is deemed improper.

- ▶ Operate the product only in compliance with the associated installation and operating instructions.
 - ▶ Operate the product only when it is in a technical condition that corresponds to the guaranteed parameters and operating conditions.
- ⇒ Zimmer GmbH shall accept no liability for any damage caused by improper use. The operator bears sole responsibility.

- The product is not suited for use in a potentially explosive atmosphere.
- The product is designated for use in closed facilities.

4 Personnel qualification

WARNING



Injuries and material damage due to inadequate qualification

If inadequately qualified personnel perform work on the product, this can cause serious injuries and significant material damage.

- ▶ All work on the product must be performed by qualified personnel.
- ▶ Before working with the product, read the document in its entirety and make sure that you have understood everything.
- ▶ Observe country-specific accident prevention regulations and the general safety notices.

The following qualifications are a prerequisite for performing various types of work on the product.

4.1 Electricians

Electricians are able to perform work on electrical systems, can recognize and avoid possible dangers and know the relevant standards and provisions due to their technical training, knowledge and experience.

4.2 Specialists

Specialists are able to perform the assigned work, can recognize and avoid possible dangers and know the relevant standards and provisions due to their technical training, knowledge and experience.

4.3 Instructed personnel

Instructed personnel have been trained by the operating company on the tasks and possible dangers of improper behavior.

4.4 Service personnel

Service personnel are able to perform the assigned work and can recognize and avoid possible dangers due to their technical training, knowledge and experience.

4.5 Additional qualifications

Persons who work with the product must be familiar with the valid safety regulations and laws as well as the standards, guidelines and laws listed in this document.

Personnel who work with the product must have facility-issued authorization to commission, program, configure, operate, maintain and also decommission this product.

5 Product description

The product is used to detect the piston stroke for drives with axially and diametrically magnetized magnets. The product is used, for example, in combination with pneumatic cylinders, grippers or slides.

The product has an analog output. IO-Link enables the setting of eight switch points and/or the detection of eight positions. In addition, various diagnostic data can be recorded and output.

- ① Mounting screw
- ② Middle of the sensor
- ③ Sensor head
- ④ LED display MR (measuring range)
- ⑤ LED display PWR (power)
- ⑥ LED display (unlabeled)
- ⑦ Teach-in button
- ⑧ Operating element

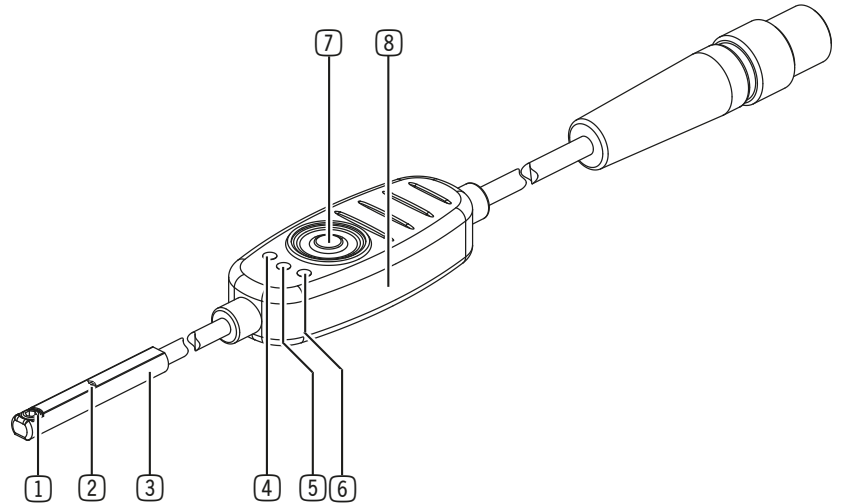

5.1 Detection range

The product is designed to detect positions in a range of 50 mm. The starting point for this range is marked with arrows on the sensor head. This point has a distance of -25 mm to the line and +25 mm to the mounting screw.

Via IO-Link, the range of 50 mm corresponds to 5,000 digits. This means one digit equals 10 µm.

The measuring range can be anywhere within the detection range and depends on the application.

A = 50 mm

B = 25.3 mm

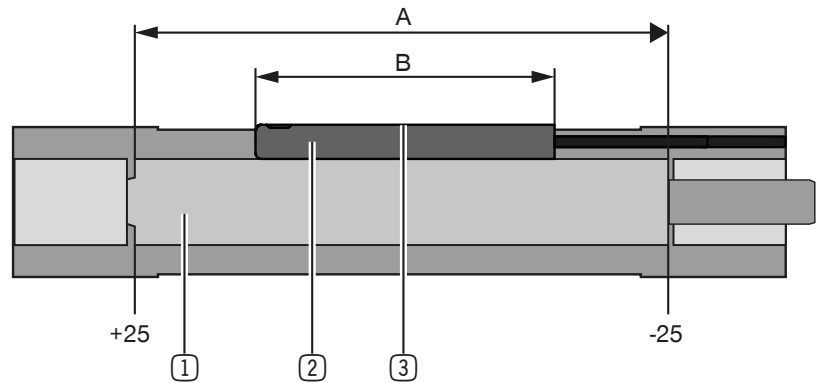

- ① Detection range
- ② Sensor head
- ③ Middle of the sensor

6 Functional description

The product consists of two sensor elements that determine the position of a magnet in the piston. Because the product measures the field strength in the X- and Y-direction, both axially and diametrically magnetized magnets can be detected.

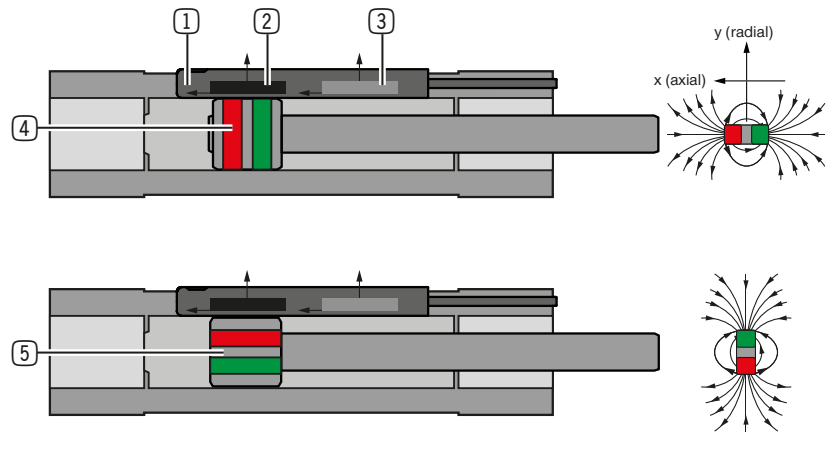

- ① Magnetic field sensor
- ② Sensor element 1
- ③ Sensor element 2
- ④ Axially magnetized magnet
- ⑤ Diametrically magnetized magnet

During manual teach-in, the *Out-of-Range* display is inactive. This can be activated via IO-Link.

The value 11 V is displayed if the magnet leaves the measuring range in a positive direction or leaves at the side of the mounting screw, and 10.5 V is displayed if the magnet leaves the measuring range in a negative direction or at the side of the line.

If the product is being used with IO-Link and the magnet leaves the measuring range, the value 32760 and/or - 32760 is displayed. If the field strength is no longer sufficient, the value 32764 is displayed.

7 Technical data

INFORMATION



- ▶ You can find the information in the technical data sheet on our website.
- ▶ This data varies within the series, depending on the specific design.
- ▶ Please contact Zimmer Customer Service if you have any questions.

8 Transportation/storage/preservation

- ▶ Store the product in its original packaging.
- ▶ During transport, make sure that no uncontrolled movements can occur if the product is already mounted on the higher-level machine unit.
 - ▶ Prior to commissioning and after transport, check all power and communication connections as well as all mechanical connections.
- ▶ Observe the following points when storing the product for longer periods of time:
 - ▶ Keep the storage location as dust-free and dry as possible.
 - ▶ Observe the temperature range and avoid temperature fluctuations.
 - ▶ Avoid wind, drafts and formation of condensation.
 - ▶ Avoid direct sunlight.
- ▶ Clean all components until all contamination has been removed.
- ▶ Visually inspect all components.
- ▶ Remove any foreign objects.
- ▶ Seal electrical connections with suitable covers.

9 Installation

NOTICE



► Use the included Allen key and/or plastic pin for installation.

INFORMATION



If the product is not taught in, the default measuring range of ± 25 mm is used.

9.1 Installing the product

Assembly requirements

| | |
|--------------------------|-----|
| Tightening torque [Nm] | 0.1 |
| Maximum temperature [°C] | +70 |
| Minimum temperature [°C] | -20 |

- Connect the product to the power supply.
- Connect the supply voltage.
- Push the sensor into the C-groove from above with the mounting screw pointing to the side.
- Position the sensor in the middle of the range of movement of the piston to ensure optimum performance.
- ⇒ When the magnet is located in the measuring range, the power LED display (PWR) lights up green and the measuring range LED display (MR) lights up yellow.
- Turn the sensor by 90° so that the mounting screw points upwards.
- Comply with the tightening torque of 0.1 Nm.
- Tighten the mounting screw using an Allen key.

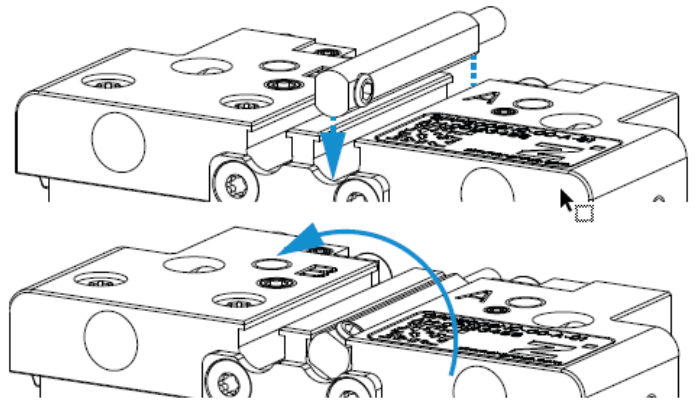

10 Electrical installation

10.1 DC

U_B : 13–30 V DC

| Pin | Color | Function |
|-----|-------|---|
| 1 | Brown | + (L+) |
| 2 | White | UOUT (is only output/used in analog operation.) |
| 3 | Blue | - (M) |
| 4 | Black | IO-Link (is only output/used in IO-operation.) |

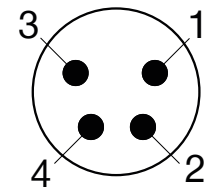

11 Commissioning

The product can either be operated in analog mode or with IO-Link. To switch from IO-Link operation to analog operation, the I/O-Link connection and the sensor power supply must be separated.

11.1.1 Commissioning the product without IO-Link

NOTICE



During manual teach-in, the *Out-of-Range* display is inactive. This can be activated via IO-Link. The value 11 V is displayed if the magnet leaves the measuring range in a positive direction or leaves at the side of the mounting screw, and 10.5 V is displayed if the magnet leaves the measuring range in a negative direction or at the side of the line.

NOTICE



If switch points are defined before complete teach-in, they will change their position during teach-in.

- ▶ Move the piston at least 5 times over the entire stroke to teach the sensor completely for the measuring range.
- ⇒ The highest degree of accuracy is achieved via complete teach-in.

11.1.2 Commissioning the product with IO-Link

NOTICE



The associated IODD in the corresponding version must be used for operation with IO-Link.

- ▶ Download the IODD from our website.

NOTICE



If switch points are defined before complete teach-in, they will change their position during teach-in.

- ▶ Move the piston at least 5 times over the entire stroke to teach the sensor completely for the measuring range.
- ⇒ The highest degree of accuracy is achieved via complete teach-in.
- ▶ In order to accelerate teach-in, perform the *Application reset*, *Reset factory settings* or *Reset trained algorithm parameter* function after installation via IO-Link.
- ⇒ In so doing, then approx. only two complete piston strokes are required for sufficient accuracy.

11.1.2.1 Influencing the measuring range

INFORMATION



Monotony violations in the fringe areas can lead to incorrect position detection. The maximum possible measuring range of the sensor is determined to prevent this.

The measuring range can be output via the *Index 16512 (0x4080)/MDC Descr, Subindex 1 (0x01)/Lower Limit* and *Subindex 2 (0x02)/Upper Limit*.

The measuring range can be influenced by the *Index 265 (0x109)/Position noise limit for application range*.

- The smaller the value, the smaller the measuring range and thus the better the performance.
- The higher the value, the higher the measuring range and thus the worse the performance.

11.1 Teaching in switch points

The product enables two teach-in variants. Both variants are performed via the Teach-in button.

11.1.1 Dynamic teach-in

Dynamic teach-in is recommended when only the two end positions of the pistons should be detected.

If three switch points of the piston should be detected, dynamic teach-in is only recommended if you are dealing with three standard statuses in the gripping process:

- Status 1 = idle: Gripper opened without workpiece (outside gripping) or gripper closed without workpiece (inside gripping)
- Status 2 = object: Gripper closed with workpiece (outside gripping) or gripper opened with workpiece (inside gripping)
- Status 3 = noobject: Gripper closed without workpiece (outside gripping) or gripper opened without workpiece (inside gripping)

NOTICE



The pistons must be operated at a speed of > 0.025 m/s for dynamic teach-in.

INFORMATION



The sensor detects the movement stops and defines the positions as switch points.

The initial position of the piston is not detected as a stop and thus not taken into account as a switch point.

In order for the sensor to detect the positions as different switch points, they must have a distance of at least 1 mm from each other.

- ▶ Press the Teach-in button for approx. 0.5 seconds.
- ⇒ The Teach menu for dynamic teach-in opens.
- ▶ Press the Teach-in button for approx. 1.5 seconds.
- ⇒ Dynamic teach-in starts.
- ▶ Move the pistons to both end positions.
- ▶ Press the Teach-in button for approx. 1.5 seconds.
- ⇒ If no switch points were detected by the sensor, both external LED displays light up yellow and the Teach menu is closed without changes.
- ▶ If the attempt fails, repeat the process until the switch points have been detected or switch to manual teach-in.
- ⇒ If the switch points were detected by the sensor, the PWR LED display lights up green and the MR LED display lights up yellow while the magnet is located within the measuring range.

11.1.2 Manual teach-in

Manual teach-in is recommended when two or three randomly placed switch points should be detected within the measuring range.

INFORMATION



The end positions can only be taught in separately. After teaching in an end position, the menu is closed and must be reopened.

- ▶ Press the Teach-in button three times for approx. 0.5 seconds.
- ⇒ The Teach menu for manual teach-in opens.
- ▶ If you want to exit the Teach menu again, repress the Teach-in button for approx. 0.5 seconds.
- ▶ To continue, press the Teach-in button for approx. 1.5 seconds.
- ⇒ Manual teach-in starts.
- ▶ Move the piston to the first end position in the negative direction or line direction.
- ▶ Press the Teach-in button for approx. 1.5 seconds.
- ⇒ If no switch point was detected by the sensor, both external LED displays light up yellow and the Teach menu is closed without changes.
- ▶ If the attempt fails, repeat the process until the switch point has been detected.
- ⇒ If the switch point was detected by the sensor, the PWR LED display lights up green and the MR LED display lights up yellow while the magnet is located within the measuring range.
- ⇒ The position is confirmed and saved and the Teach menu closes.
- ▶ Press the Teach-in button three times for approx. 0.5 seconds to teach in another switch point.
- ⇒ The Teach menu for manual teach-in opens.
- ▶ If you want to exit the Teach menu again, repress the Teach-in button for approx. 0.5 seconds.
- ▶ To continue, press the Teach-in button for approx. 1.5 seconds.
- ⇒ Manual teach-in starts.
- ▶ Press the Teach-in button for approx. 0.5 seconds to set the next position.
- ▶ Move the piston to the other end position in the positive direction or mounting screw direction.
- ▶ To confirm the position, press the Teach-in button for approx. 1.5 seconds.
- ⇒ The position is saved and the Teach menu closes.

11.2 Resetting switch points

- ▶ To reset the measuring range to the default settings, press the teach-in button for 3–5 seconds.
- ⇒ The external LED displays light up in yellow in sequence.
- ⇒ After 3–5 seconds, only the PWR LED display lights up green.
- ⇒ The measuring range has been reset.

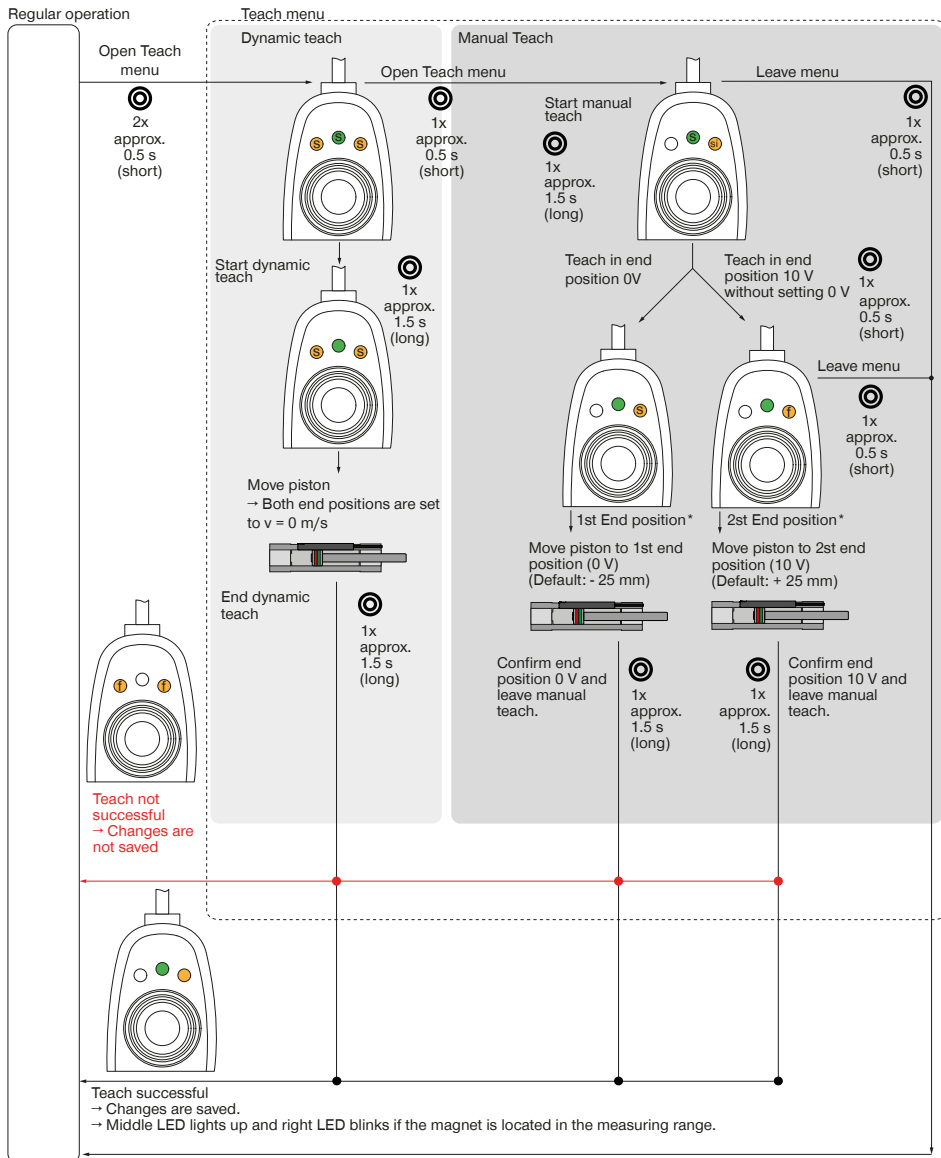

LED-Verhalten

- ○ Off
- ● On
- ⦿ ⦿ Slow blinking
- ⦿ ⦿ Inverted slow blinking
- ⦿ ⦿ Fast blinking
- ⦿ ⦿ Inverted fast blinking

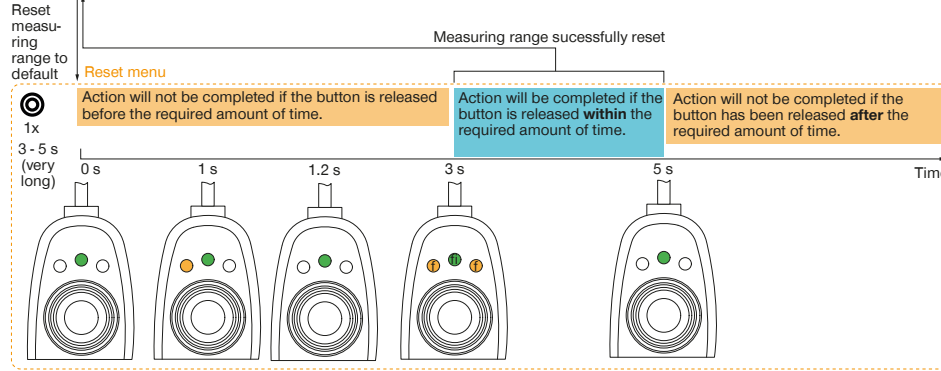

* End positions can only be taught in separately. The menu closes after teaching in an end position. You must re-open the menu to teach in the second end position.

11.3 Process data structure

INFORMATION



► Please note that the value of *Index 16512 (0x4080)/MDC Descr, Subindex 1 (0x01)/Lower Limit* and *Subindex 2 (0x02)/Upper Limit* can change while the sensor is taught the measuring range.

| | | | | | | | | |
|-------------|-------------------|--------|--------|--------|--------|--------|--------|--------|
| Bit offset | - | | | | | | | |
| Byte 0 | Bit 31 | Bit 30 | Bit 29 | Bit 28 | Bit 27 | Bit 26 | Bit 25 | Bit 24 |
| Description | Measurement value | | | | | | | |
| Subindex | - | | | | | | | |
| Data type | Integer 16 | | | | | | | |
| Bit offset | 16 | | | | | | | |
| Byte 1 | Bit 23 | Bit 22 | Bit 21 | Bit 20 | Bit 19 | Bit 18 | Bit 17 | Bit 16 |
| Description | Measurement value | | | | | | | |
| Subindex | 1 | | | | | | | |
| Data type | Integer 16 | | | | | | | |
| Bit offset | 8 | | | | | | | |
| Byte 2 | Bit 15 | Bit 14 | Bit 13 | Bit 12 | Bit 11 | Bit 10 | Bit 9 | Bit 8 |
| Description | Scale | | | | | | | |
| Subindex | 2 | | | | | | | |
| Data type | Integer 8 | | | | | | | |
| Bit offset | 7 | 6 | 5 | 4 | 3 | 2 | 1 | 0 |
| Byte 3 | Bit 7 | Bit 6 | Bit 5 | Bit 4 | Bit 3 | Bit 2 | Bit 1 | Bit 0 |
| Description | Qint.X/Alert | | | | | | | |
| Subindex | 3 | 4 | 5 | 6 | 7 | 8 | 9 | 10 |
| Data type | Boolean | | | | | | | |

11.3.1 General functions

- The exact position of the piston in the movement range of 50 mm is output via byte 0 and byte 1 and thus bits 16–31.
- The scaling is output via byte 2.
- Up to eight switch points can be output via byte 3. Alternatively, alert notifications can be output via byte 3 instead of the switch points.

11.4 Setting options via IO-Link

The following setting options are possible using IO-Link.

- Locking the Teach-in button
- Resetting settings
 - Device Reset
 - Restore Factory Settings
 - Reset diagnostic parameters
 - Reset all present alerts
 - Reset operating hours counter
 - Reset power cycles counter
 - Reset actuator cycles counter
 - Reset total actuator travel
 - Reset all actuator diagnostics parameters
 - Application reset
 - Reset trained algorithm parameter
- Setting the position offset
- Teaching-in 2 or 3 switch points dynamically
- Teaching-in up to 8 switch points manually
- Selecting the switch point mode
- Inverting the switch point logic
- Setting the switch point hysteresis
- Setting the switch point tolerance
- Setting the switch point width
- Issuing alert notifications

11.4.1 Locking the Teach-in button

The Teach-in button can be locked via *Index 12 (0x0C)/Device Access Locks, Subindex 4 (0x04)/Local User Interface*.

11.4.2 Resetting settings

- The *Device Reset* command only deletes the volatile parameters. The command can be executed via *Index 2 (0x02)/System Command, Value 128*.

| Index | Name | Volatile/Non-volatile |
|----------------|--|-----------------------|
| 4372 (0x1114) | Actuator travel | Volatile |
| 4380 (0x111C) | Cycle time | Volatile |
| 4381 (0x111D) | Dwell time | Volatile |
| 4379 (0x111B) | Actuator travel time | Volatile |
| 4375 (0x1117) | Average actuator velocity | Volatile |
| 4602 (0x11FA) | Current field strength | Volatile |
| 4604 (0x111FC) | Peak field strength | Volatile |
| 4374 (0x1116) | Total actuator travel | Non-volatile |
| 4382 (0x111E) | Cycle count | Non-volatile |
| | Qint. 1-8 SP1 / SP2 Qint. 1-8 Configuration | Non-volatile |

- The *Restore Factory Settings* command resets all settings made back to the default settings. The command can be executed via *Index 2 (0x02)/System Command, Value 130*. The following indices remain unchanged:
 - 4356 (0x1104)/Operating hours
 - 4357 (0x1105)/Power cycles, Subindex 1 (0x01)/Total
 - 4382 (0x111E)/Cycle count
 - 4374 (0x1116)/Total actuator travel
- The command *Reset Diagnostic Parameters* can be executed via *Index 2 (0x02)/System Command, Value 228*. The following indices are reset:
 - 4356 (0x1104)/Operating Hours, Subindex 2 (0x02)/Since last reset
 - 4357 (0x1105)/Power cycles, Subindex 2 (0x02)/Since last reset
 - 4382 (0x111E)/Cycle count
 - 4374 (0x1116)/Total actuator travel, Index 2 (0x02)/System Command, Value 228
- The command *Reset all present alerts* resets all alert notifications. The command can be executed via *Index 2 (0x02)/System Command, Value 229*.
- The command *Reset operating hours counter* can be executed via *Index 2 (0x02)/System Command, Value 228*. The following indices are reset:
 - 4356 (0x1104)/Operating hours, Subindex 2 (0x02)/Since last reset
- The command *Reset power cycles counter* can be executed via *Index 2 (0x02)/System Command, Value 228*. The following indices are reset:
 - 4357 (0x1105)/Power cycles
- The command *Reset actuator cycles counter* can be executed via *Index 4398 (0x112E)/Reset actuator diagnostics parameters, Value 2*. The following indices are reset:
 - 4382 (0x111E)/Cycle Count
- The command *Reset total actuator travel* can be executed via *Index 4398 (0x112E)/Reset actuator diagnostics parameters, Value 1*. The following indices are reset:
 - 4374 (0x1116)/Total actuator travel
- The command *Application reset* can be executed via *Index 2 (0x02)/System Command, Value 129*. This command can reset the same indices as the command *Restore factory settings*; however, this command has no effect on the identification parameters *Index 24, 25, 26 and 64*.
- The command *Reset trained algorithm parameter* can be executed via *Index 2 (0x02)/System Command, Value 192*. This command does not reset any diagnostic data or settings, but rather only the measured values of the algorithm. It is recommended to use this command if the product will be mounted to a different drive. Only two complete piston strokes are then required for the teach-in process.

11.4.3 Setting the position offset

The position offset value is entered in μm and added to the actual position value. It can be set via *Index 257 (0x101)/Position offset* in increments of 10 μm .

When this value is changed, this also changes the values in *Index 260 (0x104)/Detection range* and *Index 16512 (0x4080)/MDC Desc, Subindex 1 and 2*.

11.4.4 Teaching-in two or three switch points dynamically

INFORMATION



In order for the sensor to detect the positions as different switch points, they must have a distance of at least 1 mm from each other.

Dynamic teach-in can be started via *Index 2 (0x02)/System Command* using *Value 77* and stopped using *Value 76* and saved using *Value 77*.

No switch point modes can be selected for dynamic teach-in.

If the sensor detects two movement stops, the *Move, Value 130* mode is used automatically via *Subindex 2 (0x02)/Switchpoint Mode*.

If the sensor detects three movement stops, the *Grip, Value 131* mode is used automatically via *Subindex 2 (0x02)/Switchpoint Mode*.

11.4.5 Teaching-in up to eight switch points manually

INFORMATION



For manual teach-in, the switch points can have a smaller distance to each other than 1 mm.

The following example explains the procedure for manual teach-in.

- ▶ Using *Index 60 (0x3C)/Qint.1 SP1 / SP2*, set the start and end point of the switch point width for switch point 1.
 - ▶ Please note that the start and end point can only be set in the *Window mode* or *Two point mode* switch point mode.
- ▶ Using *Index 61 (0x3D)/Qint.1 Configuration*, set the switch point logic via *Subindex 1 (0x01)/Switchpoint Logic*, set the switch point mode via *Subindex 2 (0x02)/Switchpoint mode* and set the switch point hysteresis via *Subindex 3 (0x03)/Switchpoint hysteresis*.
- ▶ Repeat the process via the corresponding indices for switch point 2.
- ▶ If necessary, configure the switch points 3–8 via *Index 16384 (0x4000)* to *Index 16395 (0x400B)*.

11.4.6 Selecting the switch point mode

After manual teach-in of switch points 1–8, you can select between four different switch point modes.

Single point mode:

The switch-on and switch-off point are defined by Qint.SP1 in this mode. In the positive direction, the signal for all positions is high after the switch-on point. The signal switches to low as soon as the piston has passed the switch-on point and the switch point hysteresis.

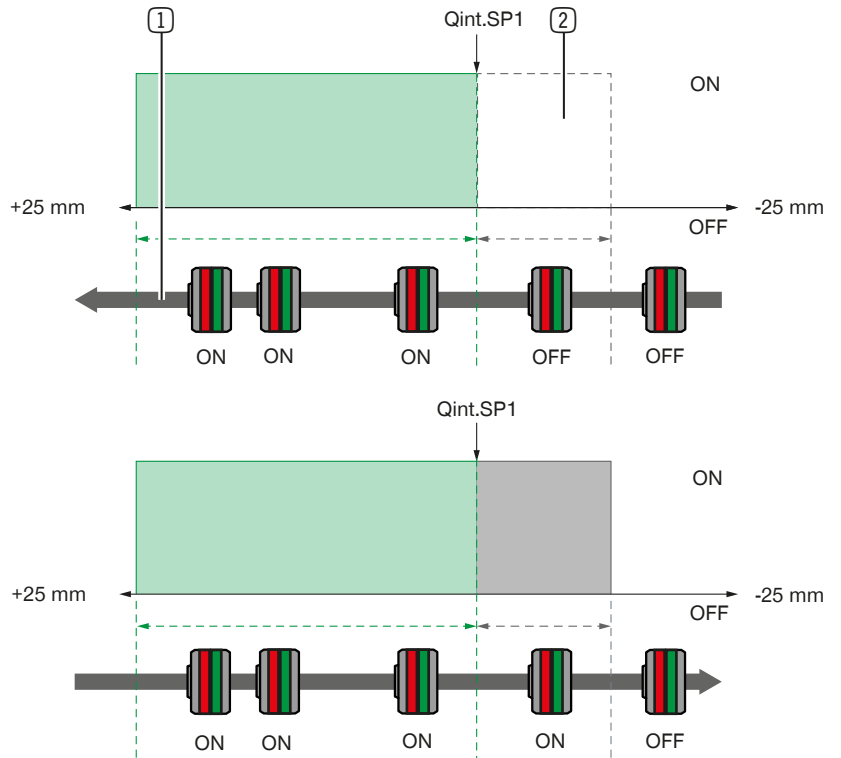

Window mode:

In this mode, the switch points 1 and 2 define a window in which the signal is continuously high. The switch point hysteresis is located symmetrically around the switch points. When the piston moves in the positive direction or in the direction of the mounting screw of the sensor, the signal within the hysteresis at switch point 1 is low and high at switch point 2. In the negative direction, it is low at switch point 2 within the hysteresis and high at switch point 1.

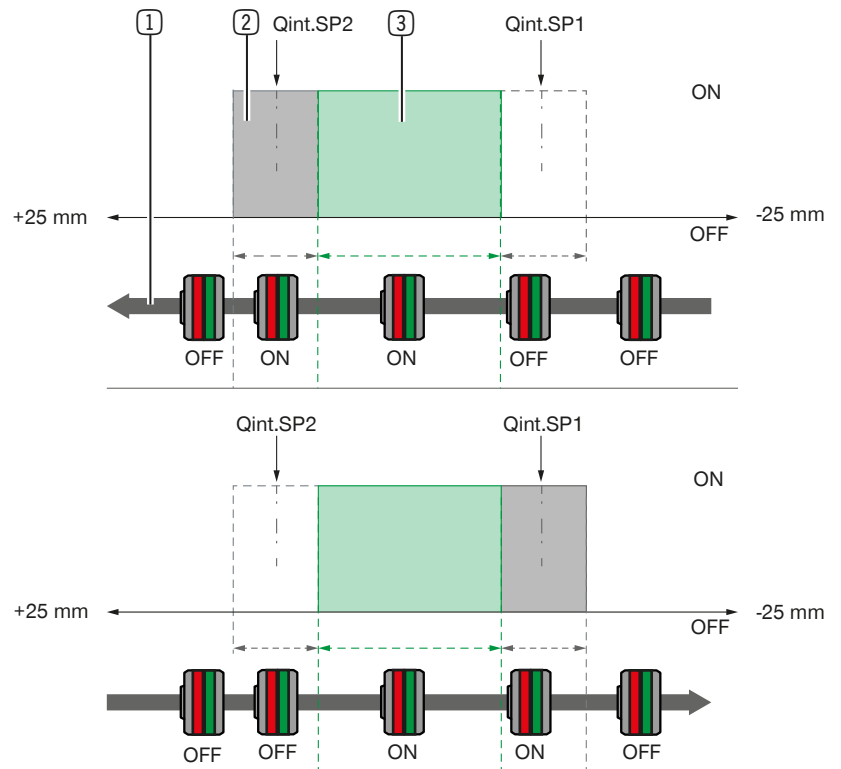

Two point mode:

In this mode, first the position of two switch points is determined. When the piston moves in the positive direction or in the direction of the mounting screw of the sensor, the signal is high as soon as the piston has passed both switch points. In the negative direction, the signal remains high as long as both switch points have passed again.

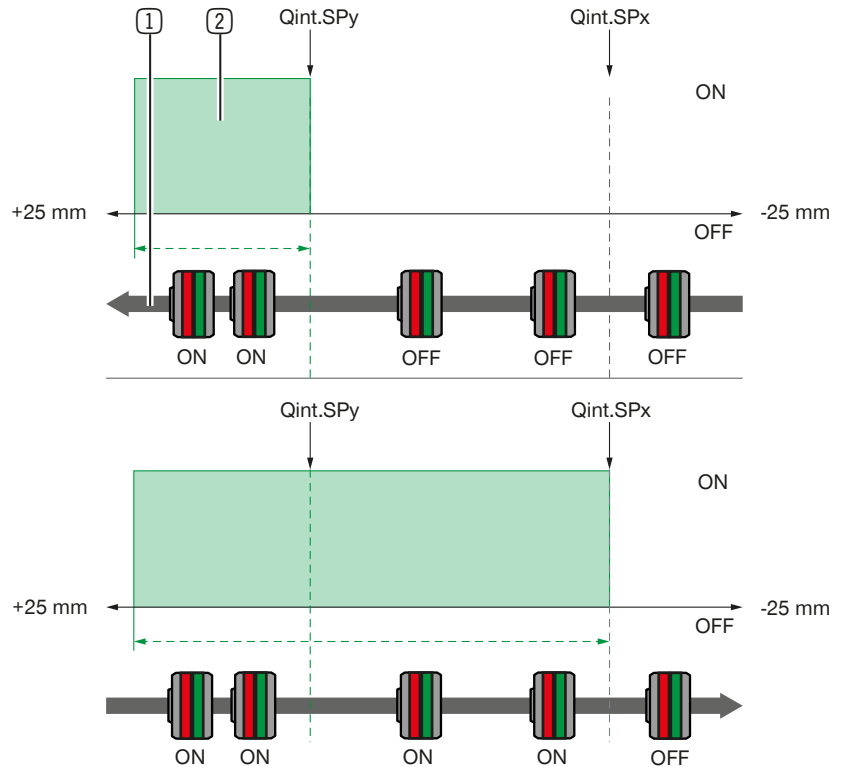

- ① Movement direction of piston
- ② Switch range

Cylinder switch mode:

In this mode, the signal is high within the switch point width and within the hysteresis that follows the switch point in the negative direction of the piston. This signal switches to low as soon as the piston leaves the hysteresis.

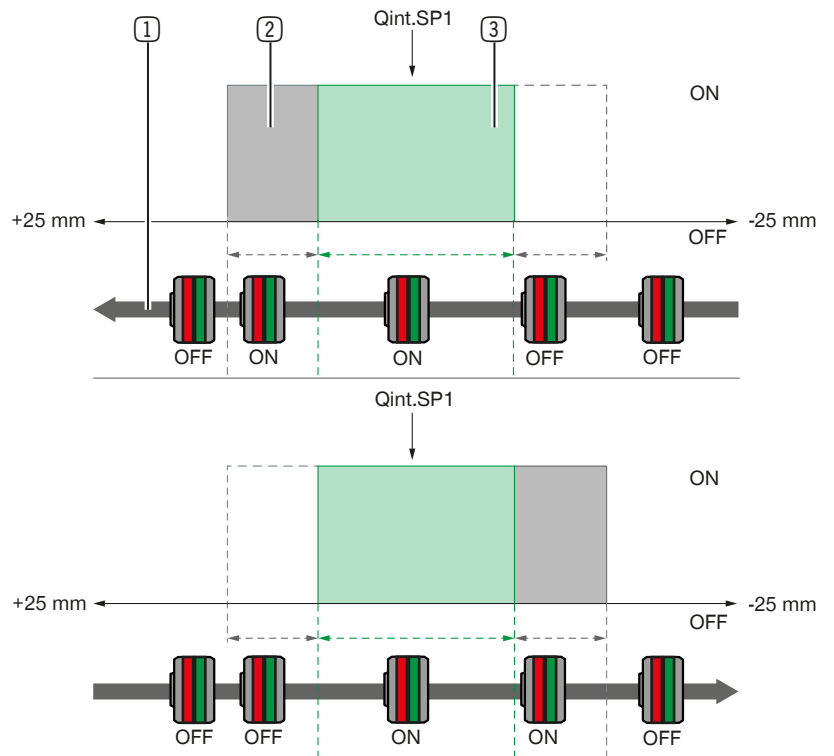

- ① Movement direction of piston
- ② Hysteresis
- ③ Switch point width

11.4.7 Switching behavior after dynamic teach-in

If the sensor detects two switch points during dynamic teach-in, the *Move* mode is selected automatically.
 If the sensor detects three switch points during dynamic teach-in, the *Grip* mode is selected automatically.
 The modes listed in the previous chapter are not available after dynamic teach-in.

11.4.7.1 Switching behavior in the Move mode during operation

If the sensor detects the piston status $v = 0$ two times during teach-in, two switch points are defined.
 Qint.1 always remains in the direction of the line, Qint.2 always remains in the direction of the mounting screw. It makes no difference as to which position is first moved.

During teach-in

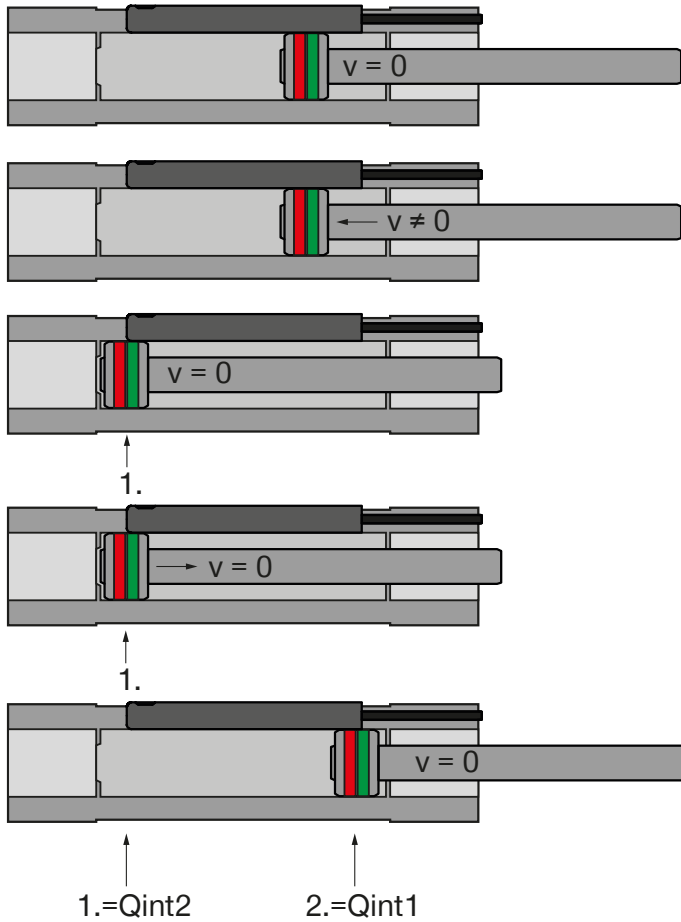

During operation

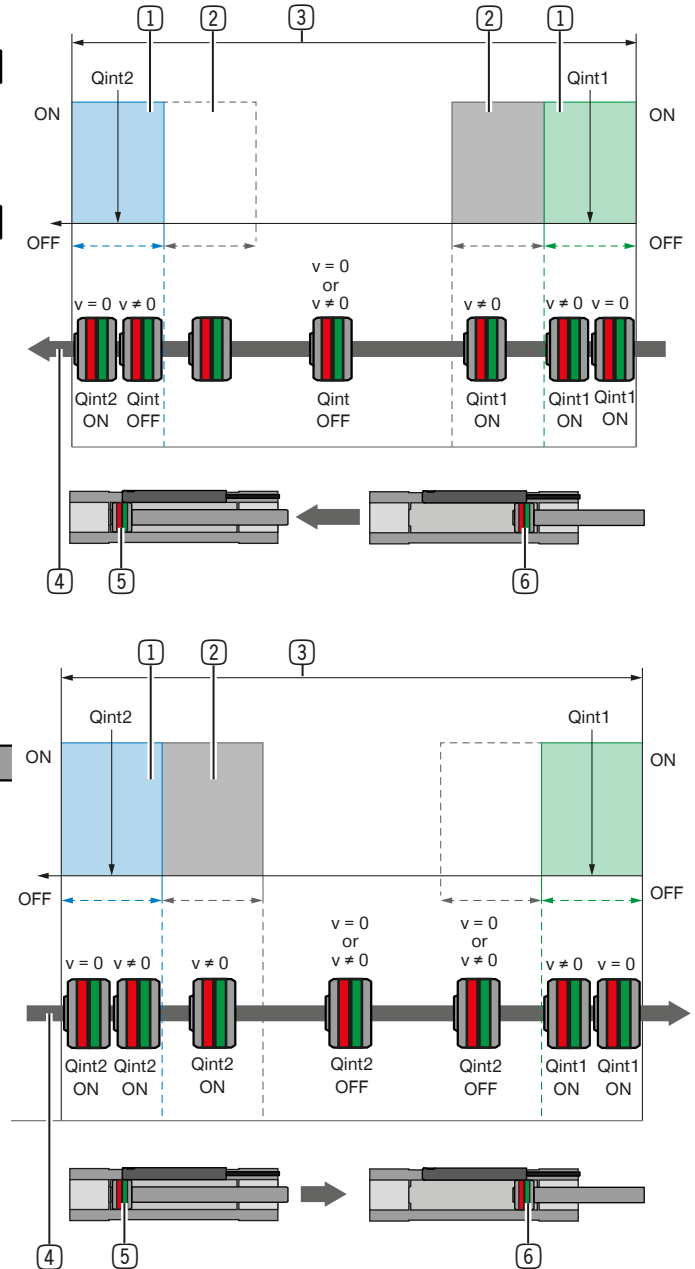

- ① Switch point tolerance
- ② Hysteresis
- ③ Travel range of piston

- ④ Movement direction of piston
- ⑤ End position in direction of mounting screw
- ⑥ End position in direction of line

11.4.7.2 Switching behavior in the Grip mode during operation

If the sensor detects the piston status $v = 0$ three times during teach-in, three switch points are defined.

The switch points are always defined as follows:

- Quint.1 = gripper closed without object (idle)
- Quint.2 = gripper open with object (object)
- Quint.3 = gripper closed without object (noobject)

During teach-in

Outside gripping

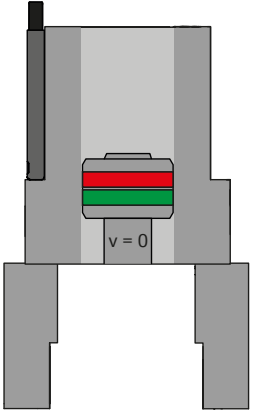
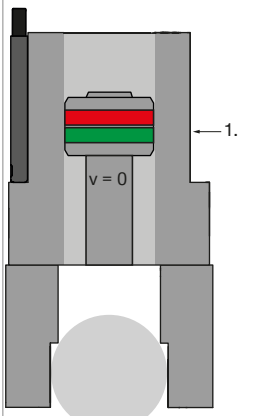
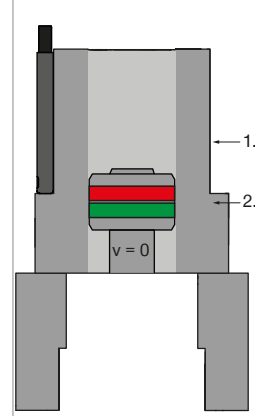
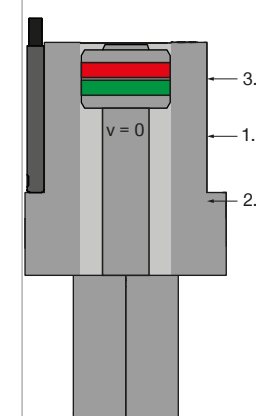
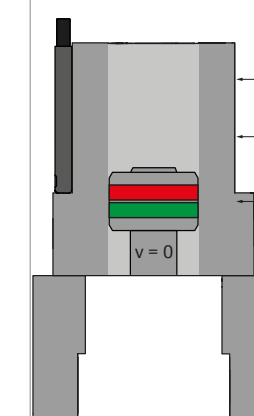
| idle | object | idle | noobject | idle |
|---|---|---|--|---|
|  |  |  |  |  |
| The starting point is not detected as a position. | First position | Second position | Third position | Switch points are assigned to the positions. |

Inside gripping

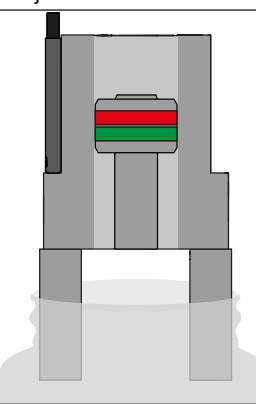
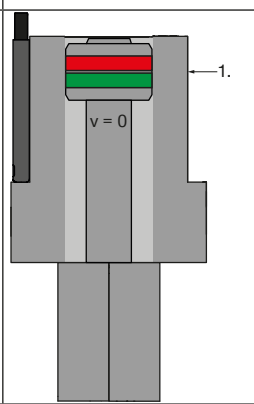
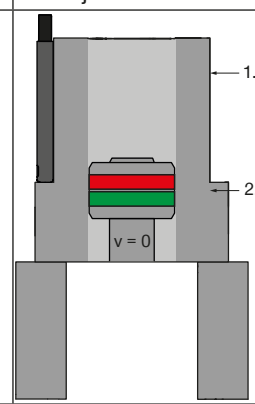
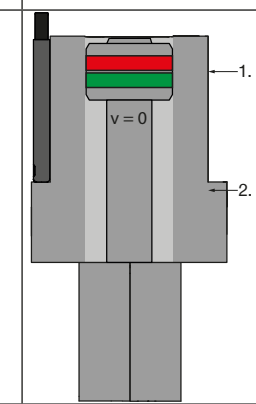
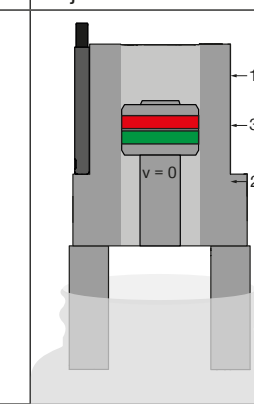
| object | idle | noobject | idle | object |
|---|---|---|--|---|
|  |  |  |  |  |
| The starting point is not detected as a position. | First position | Second position | Third position | Switch points are assigned to the positions. |

During operation

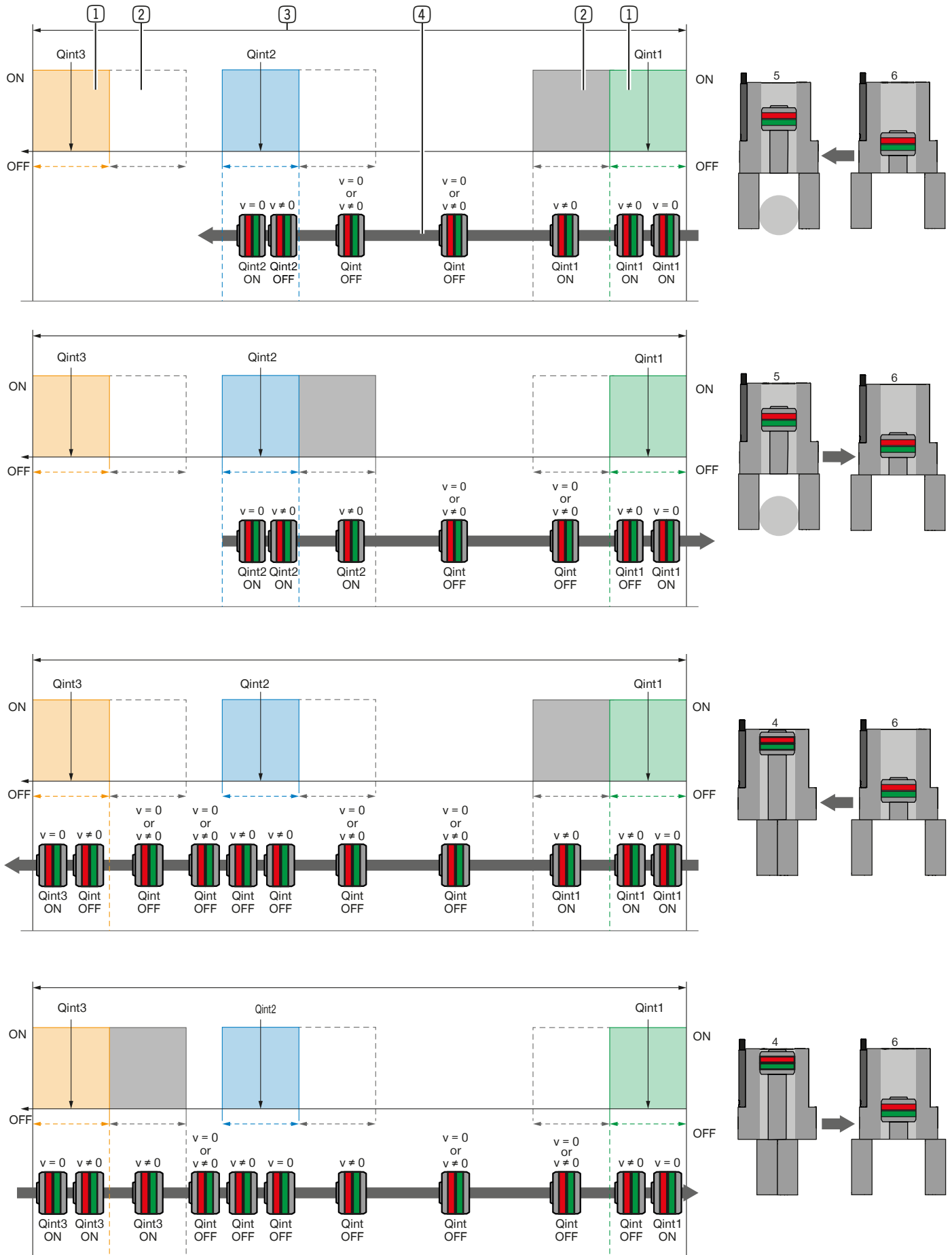

- | | | |
|--------------------------------|---|------------|
| ① Switch point tolerance |  | = noobject |
| ② Hysteresis |  | = object |
| ③ Travel range of piston |  | = idle |
| ④ Movement direction of piston | | |

11.4.8 Inverting the switch point logic

The logic of the taught-in switch points can be inverted via *Subindex 1 (0x01)/Switchpoint Logic*. The signal for the detection of a switch point is set to high by default and can thus be converted to low.

11.4.9 Adjusting the switch point hysteresis

After teach-in, the space between the switch-on and switch-off point of a switch point is 0.7 mm. This space can be adjusted via *Subindex 3 (0x03)/Switchpoint Hysteresis* in increments of 10 µm.

The maximum hysteresis is 327.67 mm, the minimum hysteresis is 0.01 mm.

11.4.10 Setting the switch point tolerance

The switch point tolerance for dynamic teach-in corresponds to the switch point width for manual teach-in.

After dynamic teach-in, the switch point tolerance is 1 mm. This tolerance can be adjusted in increments of 10 µm for the *Move* and *Grip* modes via *Index 171 (0xAB)/Switchpoint tolerance*.

11.4.11 Determining the switch point width

The switch point width for manual teach-in corresponds to the switch point tolerance for dynamic teach-in.

After manual teach-in, the switch point width for the switch point mode *Cylinder Switch mode* can be determined via *Index 170 (0xAA)/Switchpoint width*.

The switch point width is 2 mm by default and can be changed to a maximum of 10 mm.

11.4.12 Issuing alert notifications

Alert notifications are activated by default and are issued when set limit values are exceeded. Alert notifications can be read via the Indexed Service Data Unit (IDSU) in the service data or via the process date.

By default, alert notifications are issued for the following indices:

- Index 4370 (0x112)/DD – Alert flags
- Index 4400 (0x1130)/Actuator alerts

The limit values can be changed via the following indices:

- Index 4369 (0x1111)/DD – Alert limit
- Index 4399 (0x112F)/Actuator alert limits

11.5 Diagnostic functions via IO-Link

The following data are recorded by the product and can be output via the IO-Link interface:

- Stroke (actuator travel)
- Cycle time (Cycle time)
- Dwell time of piston
 - in the start position (dwell time start position)
 - in the target position (dwell time stop position)
- Travel time of piston
 - for extend (actuator travel time extend)
 - for retract (actuator travel time retract)
- Average piston velocity
 - for extend (average actuator velocity extend)
 - for retract (average actuator velocity retract)
- Current measured field strength
 - at sensor element 1 (current field strength sensor element 1)
 - at sensor element 2 (current field strength sensor element 2)
- Maximum measured field strength
 - at sensor element 1 (peak field strength sensor element 1)
 - at sensor element 2 (peak field strength sensor element 2)
- Number of cycles (cycle count)
- Total amount of piston travel (total actuator travel)
- Operating hours (operating hours count)
- Power-on and power-off cycles (power cycles)

11.5.1 Stroke

The travel of the last stroke is output in mm via *Index 4372 (0x1114)/Actuator travel*.

11.5.2 Cycle time

The duration of the last cycle is output in ms via *Index 4380 (0x111C)/Cycle time*.

One cycle corresponds to two strokes, i.e. from the start position to the end position and from the end position back to the start position. The start position is located on the side of the line, the end position on the side of the mounting screw.

The maximum cycle time and the minimum cycle time can be set via *Index 4399 (0x112F), Subindex 2 (0x02)/Min. cycle time limit* and *Subindex 3 (0x03) Max. cycle time*. In addition, an alert can also be set for exceeding the limit values via *Index 4400 (0x1130), Subindex 2 (0x02)/Min. cycle time alert* and *Subindex 3 (0x03)/Max. cycle time alert*.

11.5.3 Dwell time at the start and end position

The dwell time at the start and/or end position can be output in ms via *Index 4382 (0x111D)/Dwell time, Subindex 1 (0x01)/Start position* and *Subindex 2 (0x02)/Stop position*. The start position is located on the side of the line, the end position on the side of the mounting screw.

11.5.4 Piston travel time for extend and retract

The duration of the last stroke for extend and/or retract can be output in ms via *Index 4379 (0x111B)/Actuator travel time, Subindex 1 (0x01)/Extend* and *Subindex 2 (0x02)/Retract*. The piston travels in the direction of the mounting screw for extend and in the direction of the line for retract.

11.5.5 Average piston velocity

The average piston velocity for extend and/or retract can be output in ms via *Index 4375 (0x1117)/Average actuator velocity, Subindex 1 (0x01)/Extend* and *Subindex 2 (0x02)/Retract*. The piston travels in the direction of the mounting screw for extend and in the direction of the line for retract.

11.5.6 Current measured field strength

The current measured field strength of sensor elements 1 and 2 is output in mT via *Index 4604 (0x11FC)/Peak field strength, Subindex 1 (0x01)/Current1* and *Subindex 2 (0x02)/Current 2*. Sensor element 1 is located on the side of the line, sensor element 2 on the side of the mounting screw.

11.5.7 Maximum measured field strength

The maximum measured field strength of sensor elements 1 and 2 refer to the time period since the last power-on and power-off cycle and can be output in mT via *Index 4604 (0x11FC)/Peak field strength, Subindex 1 (0x01)/Current1* and *Subindex 2 (0x02)/Current2*. Sensor element 1 is located on the side of the line, sensor element 2 on the side of the mounting screw.

11.5.8 Number of cycles

The number of cycles is output via *Index 4382 (0x111E)/Cycle count*.

One cycle corresponds to two strokes, i.e. from the start position to the end position and from the end position back to the start position. The start position is located on the side of the line, the end position on the side of the mounting screw.

The value is only saved every 100 cycles. If the power supply is interrupted, e.g. after 99 cycles, then 0 cycles is output when power is restored.

11.5.9 Total piston travel

The total piston travel is output in m via *Index 4374 (0x1116)/Total actuator travel*. The value is only saved every 10 m. If the power supply is interrupted, e.g. after 9.99 m, then 0.0 m is output when power is restored.

11.5.10 Operating hours

Operating hours are output in h via *Index 4356 (0x1104)/Operating hours*. The index has three subindices, whereby three types of operating hours can be output.

- Absolute operating hours: *1 (0x01)/Total*
- Operating hours since the last reset: *2 (0x02)/Since last reset*
- Operating hours since the last startup: *3 (0x03)/Since startup*

11.5.11 Power-on and power-off cycles

The power-on and power-off cycles provide the number of startup and shutdown processes and are output via *Index 4357 (0x1105)/Power cycles*. One cycle corresponds to one startup and one shutdown. The total number can be output via *Subindex 1 (0x01)/Total* and the number since the last reset can be output via *Subindex 2 (0x02)/Since last reset*.

12 Operation

12.1 LED display during operation

INFORMATION



- No errors are output via the LED display.
- The following table does not describe the LED display behavior during teach-in.

| Status | LED display (unlabeled) | | LED display PWR (power) | | LED display MR (measuring range) | |
|---------------|--|-------------------------------|-------------------------|--------------------------|----------------------------------|---|
| | Signal | Meaning | Signal | Meaning | Signal | Meaning |
| Analog output | LED display does not light up. | No function during operation. | LED display flashes. | Power supply is present. | LED display lights up. | Magnet is in the measuring range. |
| | | | | | LED display does not light up. | Magnet is outside of the measuring range. |
| IO-Link | | | LED display flashes. | IO-Link is active. | | |
| Locked | When the Teach-in button is pressed and the sensor is in the locked status, the exterior LED displays flash quickly for approx. 2 seconds. | | | | | |

13 Error diagnosis

| Error | Cause | Measure |
|---|--|--|
| Green LED display PWR does not light up. | <ul style="list-style-type: none"> No voltage present. Voltage is below the limit value. | <ul style="list-style-type: none"> ▶ Check the power supply. |
| Outer LED displays are blinking. | <ul style="list-style-type: none"> No switch points are detected during a teach-in attempt outside of the detection range. | <ul style="list-style-type: none"> ▶ Position the piston in the detection range of the product. |
| | <ul style="list-style-type: none"> If no end point or just one end point are detected during dynamic teach-in, no end points will be applied. | <ul style="list-style-type: none"> ▶ Adjust the position of the sensor so that two end points are found. |
| Sensor does not find any switch points during dynamic teach-in. | <ul style="list-style-type: none"> Piston speed is too low. | <ul style="list-style-type: none"> ▶ Increase the speed of the piston or teach the sensor in manually. |
| Sensor does not switch. | | |
| End of measuring range is not detected. | | |
| Switch points move. | <ul style="list-style-type: none"> Sensor has not been taught in completely. | <ul style="list-style-type: none"> ▶ Move the piston at least 5 times over the entire stroke to teach the sensor in completely. |

14 Maintenance

Operation of the product is maintenance-free.

- ▶ Despite the maintenance-free performance mentioned, visually check the product regularly for damage and dirt.
- ▶ Clean the product if it is dirty.

15 Decommissioning/disposal

INFORMATION



When the product reaches the end of its operational phase, it can be completely disassembled and disposed of.

- ▶ Disconnect the product completely from the power supply.
- ▶ Dispose of the components properly according to the material groups.
- ▶ Comply with the locally applicable environmental and disposal regulations.

16 Declaration of Conformity

In terms of the EC Directive 2014/30/EU on electromagnetic compatibility

Name and address of the manufacturer:

Zimmer GmbH

Im Salmenkopf
77866 Rheinau, Germany

+49 7844 9138 0

info@zimmer-group.com

www.zimmer-group.com

We hereby declare that the products described below

Product designation: Magnetic field sensor with IO-Link and analog output

Type designation: MFS02-S-KHC-IL

conforms to the requirements of the 2014/35/EC directive in its design and the version we put on the market.

The following harmonized standards have been used:

- DIN EN IEC 60947-5-2 Low-voltage switchgear – Part 5-2: Control units and switch elements – proximity switches
- DIN EN IEC 63000 Technical documentation for evaluating electrical and electronic equipment regarding the restriction of hazardous substances

A full list of applied standards can be obtained from the manufacturer.

Kurt Ross

Authorized representative for
compiling the relevant technical
documents

Rheinau, Germany, 2023-07-13

(Place and date of issue)



Martin Zimmer
(Legally binding signature)
Managing Partner

17 Appendix

17.1 IO-Link supplement

17.1.1 Device features

| | |
|---|---|
| Supported Smart Sensor Profile Function Classes | none (Smart Sensor Profile not supported) |
| Supported IO-Link Time Stamp Profile modes | none (IO-Link Time Stamp Profile not supported) |
| Block Parameter Transmission | not supported |
| Data Storage functionality | supported |
| Access Locks (supported / modes) | Data Storage , Local User Interface |

17.1.2 Physical layer

Note: The IO-Link Device's max. current consumption (inclusive load current) shall not exceed the master port's max. output power current.

| | |
|---------------------------|--------|
| SIO Modus | yes |
| Min Cycle Time | 1.0 ms |
| Baudrate2 | COM3 |
| Process Data Length (IN) | 4 Byte |
| IODD version | V3.01 |
| Valid for IO-Link version | 1.1.0 |

17.1.3 Process data

Record: 4 Byte

| | | | | | | | | |
|---------------|----------------------|----|----|----|----|----|----|----|
| Bitoffset | | | | | | | | |
| Byte 0 | Measurement value 31 | 30 | 29 | 28 | 27 | 26 | 25 | 24 |
| Type/Subindex | Integer 16 | | | | | | | |

| | | | | | | | | |
|---------------|----------------------|----|----|----|----|----|----|----|
| Bitoffset | 16 | | | | | | | |
| Byte 1 | Measurement value 15 | 22 | 21 | 20 | 19 | 18 | 17 | 16 |
| Type/Subindex | Integer 16 | | | | | | | |

| | | | | | | | | | |
|---------------|-----------|----|----|----|----|----|----|---|---|
| Bitoffset | 8 | | | | | | | | |
| Byte 2 | Scale | 15 | 14 | 13 | 12 | 11 | 10 | 9 | 8 |
| Type/Subindex | Integer 8 | | | | | | | | |

| | | | | | | | | | | | | | | | | |
|---------------|--------------------|---|--------------------|---|--------------------|---|--------------------|---|--------------------|---|--------------------|---|--------------------|---|--------------------|----|
| Bitoffset | 7 | 6 | 5 | 4 | 3 | 2 | 1 | 0 | | | | | | | | |
| Byte 3 | Qint.X / Alert <1> | 7 | Qint.X / Alert <2> | 6 | Qint.X / Alert <3> | 5 | Qint.X / Alert <4> | 4 | Qint.X / Alert <5> | 3 | Qint.X / Alert <6> | 2 | Qint.X / Alert <7> | 1 | Qint.X / Alert <8> | 0 |
| Type/Subindex | Boolean | 3 | Boolean | 4 | Boolean | 5 | Boolean | 6 | Boolean | 7 | Boolean | 8 | Boolean | 9 | Boolean | 10 |

17.1.4 Service data

The following ISDUs will not be saved via Data-Storage: Teach-in Channel, Device Specific Name, Find Me, Total actuator travel [sum m] and Cycle count [sum]

| IO-Link specific | | | | | | | |
|------------------|--------------------------|-----------------|---------|---------|---|--|---------------|
| Index dec (hex) | Name | Format (Offset) | Length | Access1 | Default Value | Value / Range | Remark [Unit] |
| 12 (0x0C) | Device Access Locks | Record | 2 Byte | rw | The access to the device parameters can be restricted by setting appropriate flags within this parameter | | |
| 1 (0x01) | Parameter Write Access | Bit (0) | 1 Bit | rw | true = Locked false = Unlocked | This lock prevents the write access to all read/write parameters of the device except for the parameter 'Device Access Locks'. | |
| 2 (0x02) | Data Storage | Bit (1) | 1 Bit | rw | true = Locked false = Unlocked | This lock prevents the write access to the device parameters via the data storage mechanism. | |
| 3 (0x03) | Local Parameterization | Bit (2) | 1 Bit | rw | true = Locked false = Unlocked | This lock prevents the device settings from being changed via local operating elements on the device. | |
| 4 (0x04) | Local User Interface | Bit (3) | 1 Bit | rw | true = Locked false = Unlocked | This lock prevents the access to the device settings and display via a local user interface. The user interface is disabled. | |
| 16 (0x10) | Vendor Name | String | 64 Byte | ro | Zimmer GmbH | The vendor name that is assigned to a Vendor ID. | |
| 17 (0x11) | Vendor Text | String | 64 Byte | ro | www.zimmer-group.com | Additional information about the vendor | |
| 18 (0x12) | Product Name | String | 64 Byte | ro | MFS | Complete product name | |
| 19 (0x13) | Product ID | String | 64 Byte | ro | MFS02-S-KHC-IL | | |
| 20 (0x14) | Product Text | String | 64 Byte | ro | Magnetfeldsensor mit IO-Link und Analogausgang | | |
| 21 (0x15) | Serial Number | String | 16 Byte | ro | Unique, vendor-specific identifier of the individual device. | | |
| 22 (0x16) | Hardware Revision | String | 64 Byte | ro | Unique, vendor-specific identifier of the hardware revision of the individual device | | |
| 23 (0x17) | Firmware Revision | String | 64 Byte | ro | Unique, vendor-specific identifier of the firmware revision of the individual device. | | |
| 24 (0x18) | Application-specific Tag | String | 32 Byte | rw | ** | Possibility to mark a device with user- or application-specific information | |
| 36 (0x24) | Device Status | UInt | 8 Bit | ro | 0 = Device is OK 1 = Maintenance required 2 = Out of specification 3 = Functional check 4 = Failure | Indicator for the current device condition and diagnosis state. | |

¹ro = read only, wo = write only, rw = read/write

²COM values specify the bitrate (see IO-Link specification): COM1 (4,8 kbit/s), COM2 (38,4 kbit/s), COM3 (230,4 kbit/s)

| IO-Link specific | | | | | | | |
|------------------|------------------------|-----------------|----------|---------|--|---|---------------|
| Index dec (hex) | Name | Format (Offset) | Length | Access1 | Default Value | Value / Range | Remark [Unit] |
| 37 (0x25) | Detailed Device Status | Array | 192 Byte | ro | Octet String [64] | List of all currently pending events in the device. | |
| 40 (0x28) | PD Input | PD In | 4 Byte | ro | Last valid process input data of the device. | | |

| Device specific | | | | | | | |
|-----------------|------------------------|-----------------|---------|---------------------|---------------|---|--|
| Index dec (hex) | Name | Format (Offset) | Length | Access ¹ | Default Value | Value / Range | Remark [Unit] |
| 13 (0x0D) | Profile Characteristic | Record | 6 Byte | ro | | | |
| 1 (0x01) | Profile Identifier | Bit (32) | 16 Bit | ro | 10 | | |
| 2 (0x02) | Profile Identifier | Bit (16) | 16 Bit | ro | 49 | | |
| 3 (0x03) | Profile Identifier | Bit (0) | 16 Bit | ro | 16384 | | |
| 14 (0x0E) | PDInput descriptor | Array | 3 Byte | ro | | Octet String [1] | |
| 15 (0x0F) | PDOutput descriptor | Array | 3 Byte | ro | | Octet String [1] | |
| 25 (0x19) | Function Tag | String | 32 Byte | rw | *** | Function Tag | |
| 26 (0x1A) | Location Tag | String | 32 Byte | rw | *** | Function Tag | |
| 58 (0x3A) | Teach-in Channel | UInt | 8 Bit | rw | 0 | 0 = Default Quint (Qint.1) 1 = Qint.1 2 = Qint.2 3 = Qint.3 4 = Qint.4 5 = Qint.5 6 = Qint.6 7 = Qint.7 8 = Qint.8 | The Quint channel that is going to be taught |
| 59 (0x3B) | Teach-in Result | Record | 1 Byte | ro | | | Teach-in result provides feedback on the status and the results of the teach-in activities |
| 60 (0x3C) | Qint.1 SP1 / SP2 | Record | 4 Byte | rw | | | |
| 1 (0x01) | SP1 | Bit (16) | 16 Bit | rw | 0 | Setpoint 1 | |
| 2 (0x02) | SP2 | Bit (0) | 16 Bit | rw | 0 | Setpoint 2 | |
| 61 (0x3D) | Qint.1 Configuration | Record | 4 Byte | rw | | | |
| 1 (0x01) | Switchpoint Logic | Bit (24) | 8 Bit | rw | 0 | 0 = Not inverted 1 = Inverted | |
| 2 (0x02) | Switchpoint Mode | Bit (16) | 8 Bit | rw | 0 | 0 = Deactivated 1 = Single Point Mode 2 = Window Mode 3 = Two Point Mode 129 = Cylinder Switch Mode 130 = Move 131 = Grip | |
| 3 (0x03) | Switchpoint Hysteresis | Bit (0) | 16 Bit | rw | 70 | [x10µm] | |
| 62 (0x3E) | Qint.2 SP1 / SP2 | Record | 4 Byte | rw | | | |
| 1 (0x01) | SP1 | Bit (16) | 16 Bit | rw | 0 | Setpoint 1 | |
| 2 (0x02) | SP2 | Bit (0) | 16 Bit | rw | 0 | Setpoint 2 | |
| 63 (0x3F) | Qint.2 Configuration | Record | 4 Byte | rw | | | |
| 1 (0x01) | Switchpoint Logic | Bit (24) | 8 Bit | rw | 0 | 0 = Not inverted 1 = Inverted | |
| 2 (0x02) | Switchpoint Mode | Bit (16) | 8 Bit | rw | 0 | 0 = Deactivated 1 = Single Point Mode 2 = Window Mode 3 = Two Point Mode 129 = Cylinder Switch Mode 130 = Move 131 = Grip | |

¹ro = read only, wo = write only, rw = read/write

²COM values specify the bitrate (see IO-Link specification): COM1 (4,8 kbit/s), COM2 (38,4 kbit/s), COM3 (230,4 kbit/s)

| Device specific | | | | | | | |
|-----------------|---|-----------------|---------|---------------------|---|--|--|
| Index dec (hex) | Name | Format (Offset) | Length | Access ¹ | Default Value | Value / Range | Remark [Unit] |
| 3 (0x03) | Switchpoint Hysteresis | Bit (0) | 16 Bit | rw | 70 | [x10µm] | |
| 64 (0x40) | Device Specific Name | String | 32 Byte | rw | *** | | |
| 67 (0x43) | Process data user definition | Record | 8 Byte | rw | Define the contents of the process data | | |
| 1 (0x01) | Bit 0 | Bit (56) | 8 Bit | rw | 1 | 0 = Set bit to constant 0 1 = Quint.1 2 = Quint.2 3 = Quint.3 4 = Quint.4 5 = Quint.5 6 = Quint.6 7 = Quint.7 8 = Quint.8 60 = Group alert: Cycle time 65 = Direct alert: Operating hours max. 68 = Direct alert: Power cycles max. 69 = Direct alert: Cycle count max. 90 = Direct alert: Total actuator travel max. | Content of process data bit 0 |
| 2 (0x02) | Bit 1 | Bit (48) | 8 Bit | rw | 2 | Compare value range in subindex 1 | Content of process data bit 1 |
| 3 (0x03) | Bit 2 | Bit (40) | 8 Bit | rw | 3 | Compare value range in subindex 1 | Content of process data bit 2 |
| 4 (0x04) | Bit 3 | Bit (32) | 8 Bit | rw | 4 | Compare value range in subindex 1 | Content of process data bit 3 |
| 5 (0x05) | Bit 4 | Bit (24) | 8 Bit | rw | 5 | Compare value range in subindex 1 | Content of process data bit 4 |
| 6 (0x06) | Bit 5 | Bit (16) | 8 Bit | rw | 6 | Compare value range in subindex 1 | Content of process data bit 5 |
| 7 (0x07) | Bit 6 | Bit (8) | 8 Bit | rw | 7 | Compare value range in subindex 1 | Content of process data bit 6 |
| 8 (0x08) | Bit 7 | Bit (0) | 8 Bit | rw | 8 | Compare value range in subindex 1 | Content of process data bit 7 |
| 120 (0x78) | Process data select | UInt | 8 Bit | rw | 0 | 0 = Measurement value (2 Bytes) + Scale (1 Byte) + 8xQints/Alerts (1 Byte) | |
| 121 (0x79) | Pin 2 configuration | UInt | 8 Bit | rw | 36 | 0 = Deactivated 36 = Quint.2 | |
| 170 (0xAA) | Switchpoint width [x10µm] | Record | 16 Byte | rw | Switchpoint width | | |
| 1 (0x01) | Qint.1 width | Bit (112) | 16 Bit | rw | 200 | 0...1000 | [x10µm] |
| 2 (0x02) | Qint.2 width | Bit (96) | 16 Bit | rw | 200 | 0...1000 | [x10µm] |
| 3 (0x03) | Qint.3 width | Bit (80) | 16 Bit | rw | 200 | 0...1000 | [x10µm] |
| 4 (0x04) | Qint.4 width | Bit (64) | 16 Bit | rw | 200 | 0...1000 | [x10µm] |
| 5 (0x05) | Qint.5 width | Bit (48) | 16 Bit | rw | 200 | 0...1000 | [x10µm] |
| 6 (0x06) | Qint.6 width | Bit (32) | 16 Bit | rw | 200 | 0...1000 | [x10µm] |
| 7 (0x07) | Qint.7 width | Bit (16) | 16 Bit | rw | 200 | 0...1000 | [x10µm] |
| 8 (0x08) | Qint.8 width | Bit (0) | 16 Bit | rw | 200 | 0...1000 | [x10µm] |
| 171 (0xAB) | Switchpoint tolerance [x10µm] | Record | 6 Byte | rw | Switchpoint tolerance | | |
| 1 (0x01) | Qint.1 tolerance | Bit (32) | 16 Bit | rw | 100 | [x10µm] | |
| 2 (0x02) | Qint.2 tolerance | Bit (16) | 16 Bit | rw | 100 | [x10µm] | |
| 3 (0x03) | Qint.3 tolerance | Bit (0) | 16 Bit | rw | 100 | [x10µm] | |
| 204 (0xCC) | Find Me | UInt | 8 Bit | rw | 0 | 0 = Stop FindMe 1 = LED flash | |
| 256 (0x100) | Position [x10µm] | Int | 16 Bit | ro | Current position [x10µm] | | |
| 257 (0x101) | Position offset [x10µm] | Int | 16 Bit | rw | 0 | -27500...27500 | Offset that is added to the current position [x10µm] |
| 258 (0x102) | Out of range detection | UInt | 8 Bit | rw | 0 | 0 = Always off 1 = Always on 2 = Automatic | |
| 260 (0x104) | Detection range [x10µm] | Record | 4 Byte | rw | | | |
| 1 (0x01) | Minimal position | Bit (16) | 16 Bit | rw | -2500 | -30000...30000 | [x10µm] |
| 2 (0x02) | Maximal position | Bit (0) | 16 Bit | rw | -2500 | -30000...30000 | [x10µm] |
| 261 (0x105) | Current position repeatability [mm] | Float | 4 Byte | ro | [mm] | | |
| 265 (0x109) | Position noise limit for application range [mm] | Float | 4 Byte | rw | 0.3 | [mm] | |
| 4356 (0x1104) | Operating hours | Record | 12 Byte | ro | Operating Hours data | | |
| 1 (0x01) | Total | Bit (64) | 32 Bit | ro | [h] | | |
| 2 (0x02) | Since last reset | Bit (32) | 32 Bit | ro | [h] | | |
| 3 (0x03) | Since startup | Bit (0) | 32 Bit | ro | [h] | | |
| 4357 (0x1105) | Power cycles | Record | 8 Byte | ro | Power Cycles data | | |
| 1 (0x01) | Total | Bit (32) | 32 Bit | ro | | | |
| 2 (0x02) | Since last reset | Bit (0) | 32 Bit | ro | | | |

1 ro = read only, wo = write only, rw = read/write

2 COM values specify the bitrate (see IO-Link specification): COM1 (4,8 kbit/s), COM2 (38,4 kbit/s), COM3 (230,4 kbit/s)

| Device specific | | | | | | | |
|-----------------|--|-----------------|---------|---------------------|---|--|---------------|
| Index dec (hex) | Name | Format (Offset) | Length | Access ¹ | Default Value | Value / Range | Remark [Unit] |
| 4367 (0x110F) | DD - Reset device diagnostics parameters | Ulnt | 8 Bit | wo | 1 = Reset operating hours 2 = Reset power cycles 255 = Reset all device diagnostics parameters | DD - reset the device diagnostics parameters | |
| 4368 (0x1110) | DD - Alert source | Record | 2 Byte | rw | Set the alert source of the device diagnosis data | | |
| 1 (0x01) | Operating hours alert source | Bit (8) | 8 Bit | rw | 0 | 0 = Total 1 = Since Last Reset 2 = Since Startup | |
| 2 (0x02) | Power cycles alert source | Bit (0) | 8 Bit | rw | 0 | 0 = Total 1 = Since Last Reset | |
| 4369 (0x1111) | DD - Alert limit | Record | 8 Byte | rw | Set the limits of the device diagnosis alerts | | |
| 1 (0x01) | Operating hours limit | Bit (32) | 32 Bit | rw | 876000 | 0...876000 | [h] |
| 2 (0x02) | Power cycles limit | Bit (0) | 32 Bit | rw | 1000000 | | |
| 4370 (0x1112) | DD - Alert flags | Record | 1 Byte | ro | Get the device diagnosis alerts | | |
| 4372 (0x1114) | Actuator travel [x10µm] | Ulnt | 16 Bit | ro | [x10µm] | | |
| 4374 (0x1116) | Total actuator travel [sum m] | Ulnt | 32 Bit | rw | [m] | | |
| 4375 (0x1117) | Average actuator velocity [m/s] | Record | 8 Byte | ro | | | |
| 1 (0x01) | Extend (positive direction) | Bit (32) | 4 Byte | ro | Format = Float [m/s] | | |
| 2 (0x02) | Retract (negative direction) | Bit (0) | 4 Byte | ro | Format = Float [m/s] | | |
| 4379 (0x111B) | Actuator travel time [ms] | Record | 8 Byte | ro | | | |
| 1 (0x01) | Extend (positive direction) | Bit (32) | 4 Byte | ro | Format = Float [m/s] | | |
| 2 (0x02) | Retract (negative direction) | Bit (0) | 4 Byte | ro | Format = Float [m/s] | | |
| 4380 (0x111C) | Cycle time [ms] | Float | 8 Byte | ro | [ms] | | |
| 4381 (0x111D) | Dwell time [ms] | Record | 4 Byte | ro | | | |
| 1 (0x01) | Start position | Bit (32) | 4 Byte | ro | Format = Float [m/s] | | |
| 2 (0x02) | Start position | Bit (0) | 4 Byte | ro | Format = Float [m/s] | | |
| 4382 (0x111E) | Cycle count [sum] | Ulnt | 32 Bit | rw | | | |
| 4398 (0x112E) | Reset actuator diagnostics parameters | Ulnt | 8 Bit | ro | 1 = Reset total actuator travel 2 = Reset actuator cycles 255 = Reset all actuator diagnostics parameters | DD - reset the device diagnostics parameters | |
| 4399 (0x112F) | Actuator alert limits | Record | 16 Byte | rw | Set the limits of the actuator alerts | | |
| 1 (0x01) | Total actuator travel limit | Bit (96) | 32 Bit | rw | 100000 | [m] | |
| 2 (0x02) | Min. cycle time limit | Bit (64) | 4 Byte | rw | 0 | Format = Float [ms] | |
| 3 (0x03) | Max. cycle time limit | Bit (32) | 4 Byte | rw | 86400000 | Format = Float [ms] | |
| 4 (0x04) | Cycle count limit | Bit (0) | 32 Bit | rw | 1000000 | | |
| 4400 (0x1130) | Actuator alerts | Record | 2 Byte | ro | Get the actuator alerts | | |
| 4602 (0x11FA) | Current field strength [mT] | Record | 8 Byte | ro | Magnetic field strength of magnetic elements | | |
| 1 (0x01) | Current1 | Bit (32) | 4 Byte | ro | Magnetic field strength of magnetic element 1. Format = Float [mT] | | |
| 2 (0x02) | Current2 | Bit (0) | 4 Byte | ro | Magnetic field strength of magnetic element 2. Format = Float [mT] | | |
| 4604 (0x11FC) | Peak field strength [mT] | Record | 8 Byte | ro | | | |
| 1 (0x01) | Current1 | Bit (32) | 4 Byte | ro | Magnetic field strength of magnetic element 1. Format = Float [mT] | | |
| 2 (0x02) | Current2 | Bit (0) | 4 Byte | ro | Magnetic field strength of magnetic element 2. Format = Float [mT] | | |
| 4842 (0x12EA) | Alert settings | Record | 8 Byte | rw | | | |

1 ro = read only, wo = write only, rw = read/write

2 COM values specify the bitrate (see IO-Link specification): COM1 (4,8 kbit/s), COM2 (38,4 kbit/s), COM3 (230,4 kbit/s)

| Device specific | | | | | | | |
|-----------------|---------------------------------|-----------------|---------|---------------------|-----------------|---|---------------|
| Index dec (hex) | Name | Format (Offset) | Length | Access ¹ | Default / Value | Value / Range | Remark [Unit] |
| 1 (0x01) | Alert delay time [ms] | Bit (32) | 32 Bit | rw | 0 | 0...1000000 = Alert delay time between 0 and 1000s | |
| 2 (0x02) | Automatic alert reset time [ms] | Bit (0) | 32 Bit | rw | -1 | -1...1000000 = Automatic alert reset time between 0 and 1000s, -1 deactivates the automatic alert reset. | |
| 14905 (0x3A39) | Platform version | String | 32 Byte | ro | | | |
| 14908 (0x3A3C) | Sensor head firmware version | String | 32 Byte | ro | | | |
| 16384 (0x4000) | Qint.3 SP1 / SP2 | Record | 4 Byte | rw | | | |
| 1 (0x01) | SP1 | Bit (16) | 16 Bit | rw | 0 | Setpoint 1 | |
| 2 (0x02) | SP2 | Bit (0) | 16 Bit | rw | 0 | Setpoint 2 | |
| 16385 (0x4001) | Qint.3 Configuration | Record | 4 Byte | rw | | | |
| 1 (0x01) | Switchpoint Logic | Bit (24) | 8 Bit | rw | 0 | 0 = Not inverted 1 = Inverted | |
| 2 (0x02) | Switchpoint Mode | Bit (16) | 8 Bit | rw | | 0 = Deactivated 1 = Single Point Mode 2 = Window Mode 3 = Two Point Mode 129 = Cylinder Switch Mode 131 = Grip | |
| 3 (0x03) | Switchpoint Hysteresis | Bit (0) | 16 Bit | rw | 70 | [×10µm] | |
| 16386 (0x4002) | Qint.4 SP1 / SP2 | Record | 4 Byte | rw | | | |
| 1 (0x01) | SP1 | Bit (16) | 16 Bit | rw | 0 | Setpoint 1 | |
| 2 (0x02) | SP2 | Bit (0) | 16 Bit | rw | 0 | Setpoint 2 | |
| 16387 (0x4003) | Qint.4 Configuration | Record | 4 Byte | rw | | | |
| 1 (0x01) | Switchpoint Logic | Bit (24) | 8 Bit | rw | 0 | 0 = Not inverted 1 = Inverted | |
| 2 (0x02) | Switchpoint Mode | Bit (16) | 8 Bit | rw | 0 | 0 = Deactivated 1 = Single Point Mode 2 = Window Mode 3 = Two Point Mode 129 = Cylinder Switch Mode | |
| 3 (0x03) | Switchpoint Hysteresis | Bit (0) | 16 Bit | rw | 70 | [×10µm] | |
| 16388 (0x4004) | Qint.5 SP1 / SP2 | Record | 4 Byte | rw | | | |
| 1 (0x01) | SP1 | Bit (16) | 16 Bit | rw | 0 | Setpoint 1 | |
| 2 (0x02) | SP2 | Bit (0) | 16 Bit | rw | 0 | Setpoint 2 | |
| 16389 (0x4005) | Qint.5 Configuration | Record | 4 Byte | rw | | | |
| 1 (0x01) | Switchpoint Logic | Bit (24) | 8 Bit | rw | 0 | 0 = Not inverted 1 = Inverted | |
| 2 (0x02) | Switchpoint Mode | Bit (16) | 8 Bit | rw | 0 | 0 = Deactivated 1 = Single Point Mode 2 = Window Mode 3 = Two Point Mode 129 = Cylinder Switch Mode | |
| 3 (0x03) | Switchpoint Hysteresis | Bit (0) | 16 Bit | rw | 70 | ×10µm] | |
| 16390 (0x4006) | Qint.6 SP1 / SP2 | Record | 4 Byte | rw | | | |
| 1 (0x01) | SP1 | Bit (16) | 16 Bit | rw | 0 | Setpoint 1 | |
| 2 (0x02) | SP2 | Bit (0) | 16 Bit | rw | 0 | Setpoint 2 | |
| 16391 (0x4007) | Qint.6 Configuration | Record | 4 Byte | rw | | | |
| 1 (0x01) | Switchpoint Logic | Bit (24) | 8 Bit | rw | 0 | 0 = Not inverted 1 = Inverted | |
| 2 (0x02) | Switchpoint Mode | Bit (16) | 8 Bit | rw | 0 | 0 = Deactivated 1 = Single Point Mode 2 = Window Mode 3 = Two Point Mode 129 = Cylinder Switch Mode | |
| 3 (0x03) | Switchpoint Hysteresis | Bit (0) | 16 Bit | rw | 70 | [×10µm] | |
| 16392 (0x4008) | Qint.7 SP1 / SP2 | Record | 4 Byte | rw | | | |
| 1 (0x01) | SP1 | Bit (16) | 16 Bit | rw | 0 | Setpoint 1 | |
| 2 (0x02) | SP2 | Bit (0) | 16 Bit | rw | 0 | Setpoint 2 | |

1 ro = read only, wo = write only, rw = read/write

2 COM values specify the bitrate (see IO-Link specification): COM1 (4,8 kbit/s), COM2 (38,4 kbit/s), COM3 (230,4 kbit/s)

| Device specific | | | | | | | |
|-----------------|------------------------|-----------------|---------|---------------------|---------------|---|-------------------------------|
| Index dec (hex) | Name | Format (Offset) | Length | Access ¹ | Default Value | Value / Range | Remark [Unit] |
| 16393 (0x4009) | Qint.7 Configuration | Record | 4 Byte | rw | | | |
| 1 (0x01) | Switchpoint Logic | Bit (24) | 8 Bit | rw | 0 | 0 = Not inverted 1 = Inverted | |
| 2 (0x02) | Switchpoint Mode | Bit (16) | 8 Bit | rw | 0 | 0 = Deactivated 1 = Single Point Mode 2 = Window Mode 3 = Two Point Mode 129 = Cylinder Switch Mode | |
| 3 (0x03) | Switchpoint Hysteresis | Bit (0) | 16 Bit | rw | 70 | [x10µm] | |
| 16394 (0x400A) | Qint.8 SP1 / SP2 | Record | 4 Byte | rw | | | |
| 1 (0x01) | SP1 | Bit (16) | 16 Bit | rw | 0 | Setpoint 1 | |
| 2 (0x02) | SP2 | Bit (0) | 16 Bit | rw | 0 | Setpoint 2 | |
| 16395 (0x400B) | Qint.8 Configuration | Record | 4 Byte | rw | | | |
| 1 (0x01) | Switchpoint Logic | Bit (24) | 8 Bit | rw | 0 | 0 = Not inverted 1 = Inverted | |
| 2 (0x02) | Switchpoint Mode | Bit (16) | 8 Bit | rw | 0 | 0 = Deactivated 1 = Single Point Mode 2 = Window Mode 3 = Two Point Mode 129 = Cylinder Switch Mode | |
| 3 (0x03) | Switchpoint Hysteresis | Bit (0) | 16 Bit | rw | 70 | [x10µm] | |
| 16512 (0x4080) | MDC Descr | Record | 11 Byte | ro | | | |
| 1 (0x01) | Lower Limit | Bit (56) | 32 Bit | ro | -2500 | -2147482880...2147482880 = Permissible values for the Detection range | Lower value measurement range |
| 3 (0x03) | Upper Limit | Bit (24) | 32 Bit | ro | 2500 | -2147482880...2147482880 = Permissible values for the Detection range | Lower value measurement range |
| 3 (0x03) | Unit code | Bit (8) | 16 Bit | ro | 1010 | 1010 = Distance [m] | |
| 4 (0x04) | Scale | Bit (0) | 8 Bit | ro | -5 | -128...127 = Range shifting (10 [^] scale) | |
| 17341 (0x43BD) | FW Password | String | 16 Byte | wo | | | |
| 17342 (0x43BE) | HW ID Key | String | 32 Byte | ro | | | |
| 17343 (0x43BF) | Bootmode Status | UInt | 8 Bit | ro | | 0 = Bootloader is inactive 1 = Bootloader is active | |

| Standard command | | | | | |
|------------------|----------------|--------------------------|-------|-----------------------------------|---|
| Index dec (hex) | | Access ¹ | Value | Name | Remark [Unit] |
| 2 (0x02) | System Command | wo | 65 | SP1 Single Value Teach | |
| | | | 66 | SP2 Single Value Teach | |
| | | | 75 | Dynamic Teach Start | |
| | | | 76 | Dynamic Teach Stop | |
| | | | 77 | Dynamic Teach Apply | |
| | | | 79 | Teach Cancel | |
| | | | 80 | Start unlocking sequence | |
| | | | 81 | Unlocking command 1 | |
| | | | 82 | Unlocking command 2 | |
| | | | 128 | Device Reset | Performs a system restart. All read-only parameter are rejected |
| | | | 129 | Application Reset | Reset all application specific values except the identification parameters |
| | | | 130 | Restore Factory Settings | All default parameter are reloaded |
| | | | 192 | Reset trained algorithm parameter | Reset for all actuator specific values related to position calculation of MPS-G |
| | | | 228 | Reset diagnostics parameter | Resets operating hours, power cycles, cycle count and total actuator travel |
| | 229 | Reset all present alerts | | | |

¹ ro = read only, wo = write only, rw = read/write

² COM values specify the bitrate (see IO-Link specification): COM1 (4,8 kbit/s), COM2 (38,4 kbit/s), COM3 (230,4 kbit/s)